

Welcome to the Juice Analytics presentation idea generator.

I hope this is a valuable resource for presentation writers looking for inspiration, widgets, nice-looking charts and graphics, and ideas on structuring slides.

- Zach Gemignani (zach.gemignani@juiceanalytics.com)

Widgets

Charts

Graphics

Slide structure

Widgets: Arrows, pointers and callouts

ILLUSTRATIVE

Blah blah

note

DRAFT

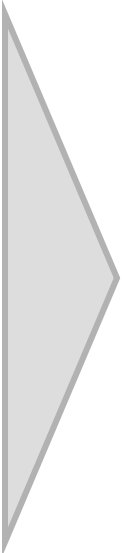

Suspended



Widgets: Harvey Balls (used to show approximate values when you don't have hard data to back it up)

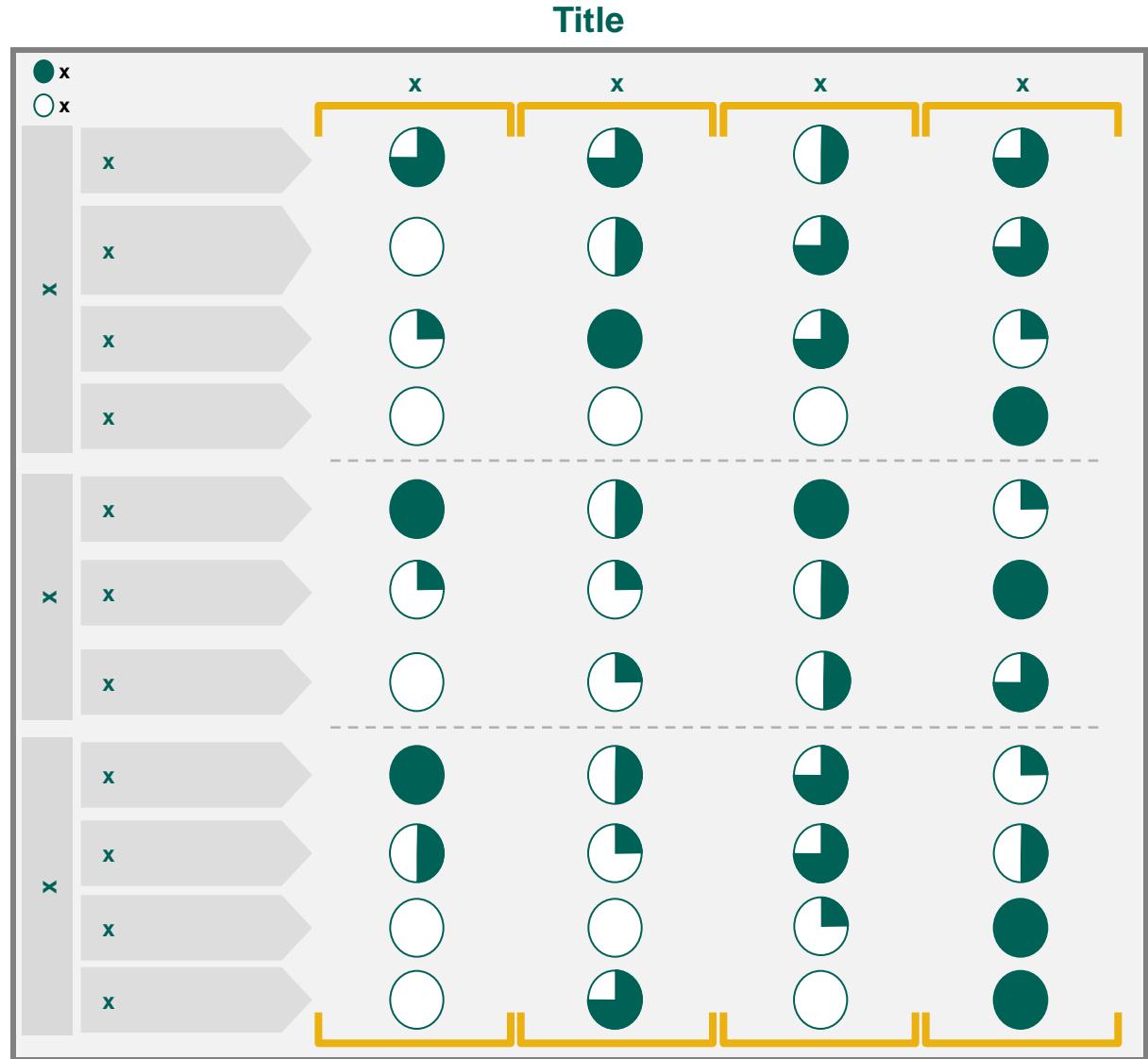
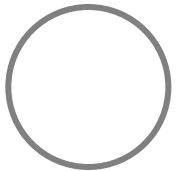
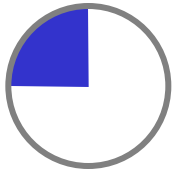
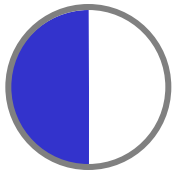
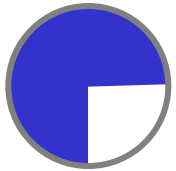
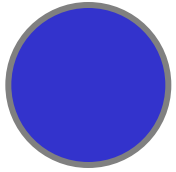

Widgets: Bullets can add a subtle style

- ▶ Here are some good bullets
- ✓ Here are some good bullets
- * Here are some good bullets
- ◆ Here are some good bullets
- Here are some good bullets

Widgets: Brackets (used to “box in” a set of information)

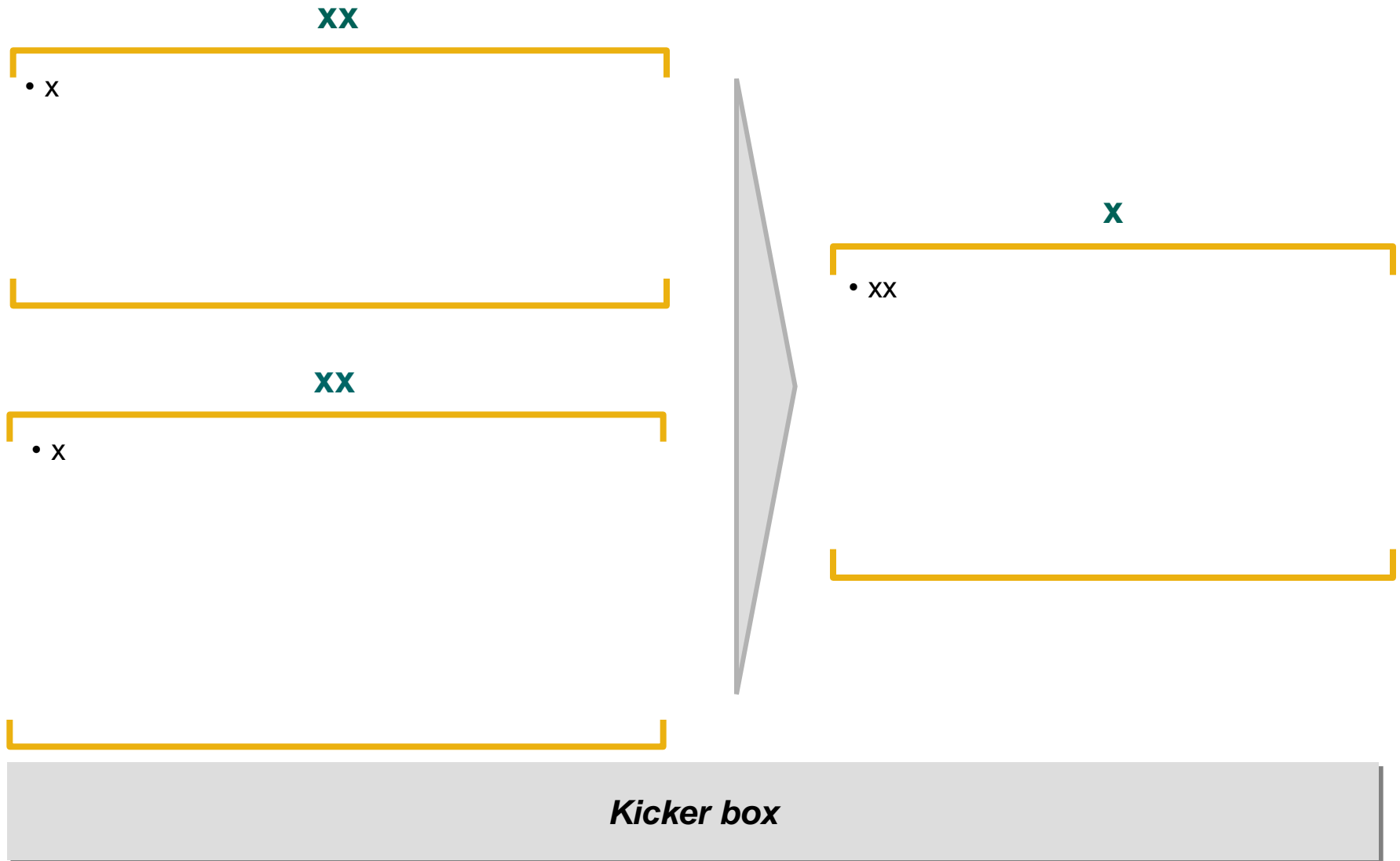

Outline

Widgets

Charts

Graphics

Slide structure

Charts: Column

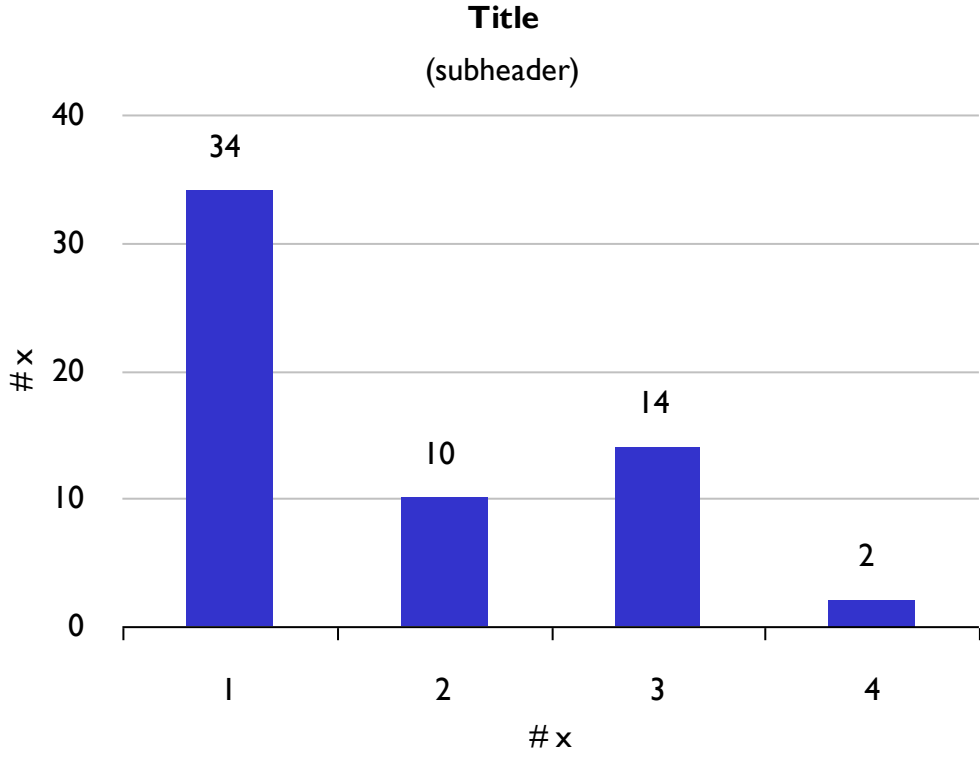

Charts: Pie

Title

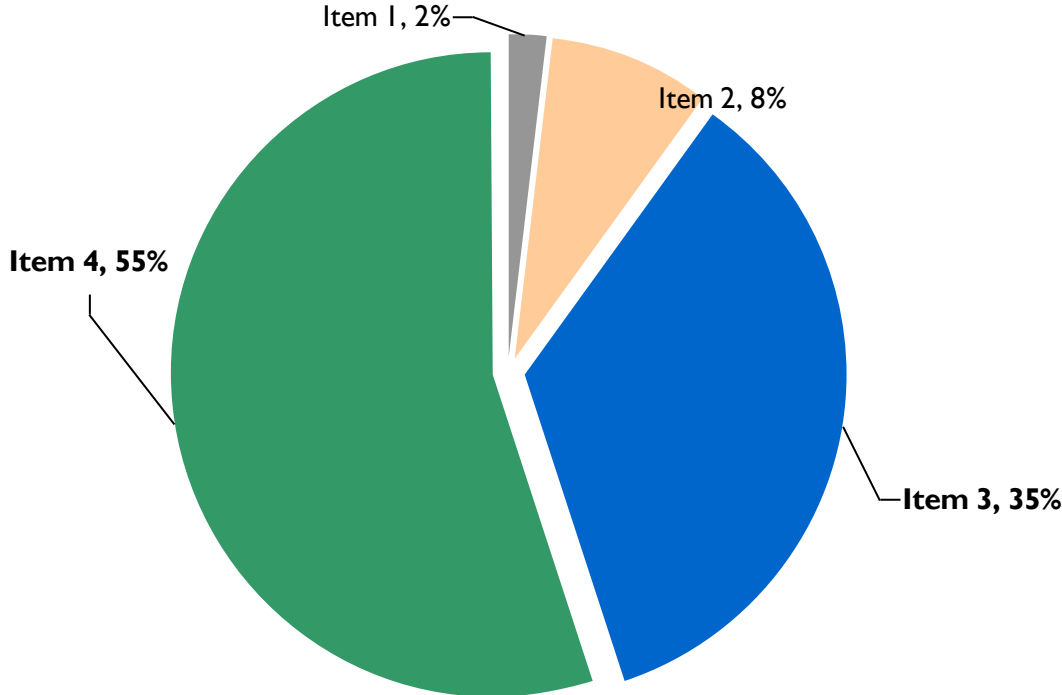

Charts: Pie with comments

Title
(subtitle)

a) X
b) X
c) x

a) X
b) X
c) X
d) x

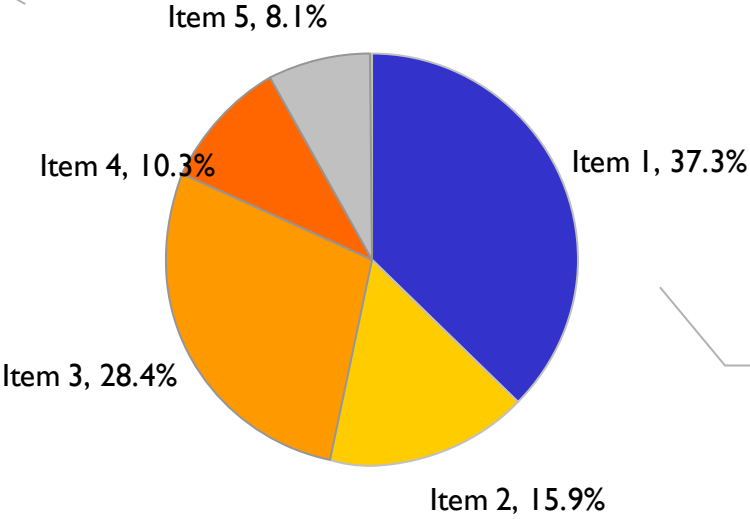

x

a) X
b) x

x

Charts: Multi-column

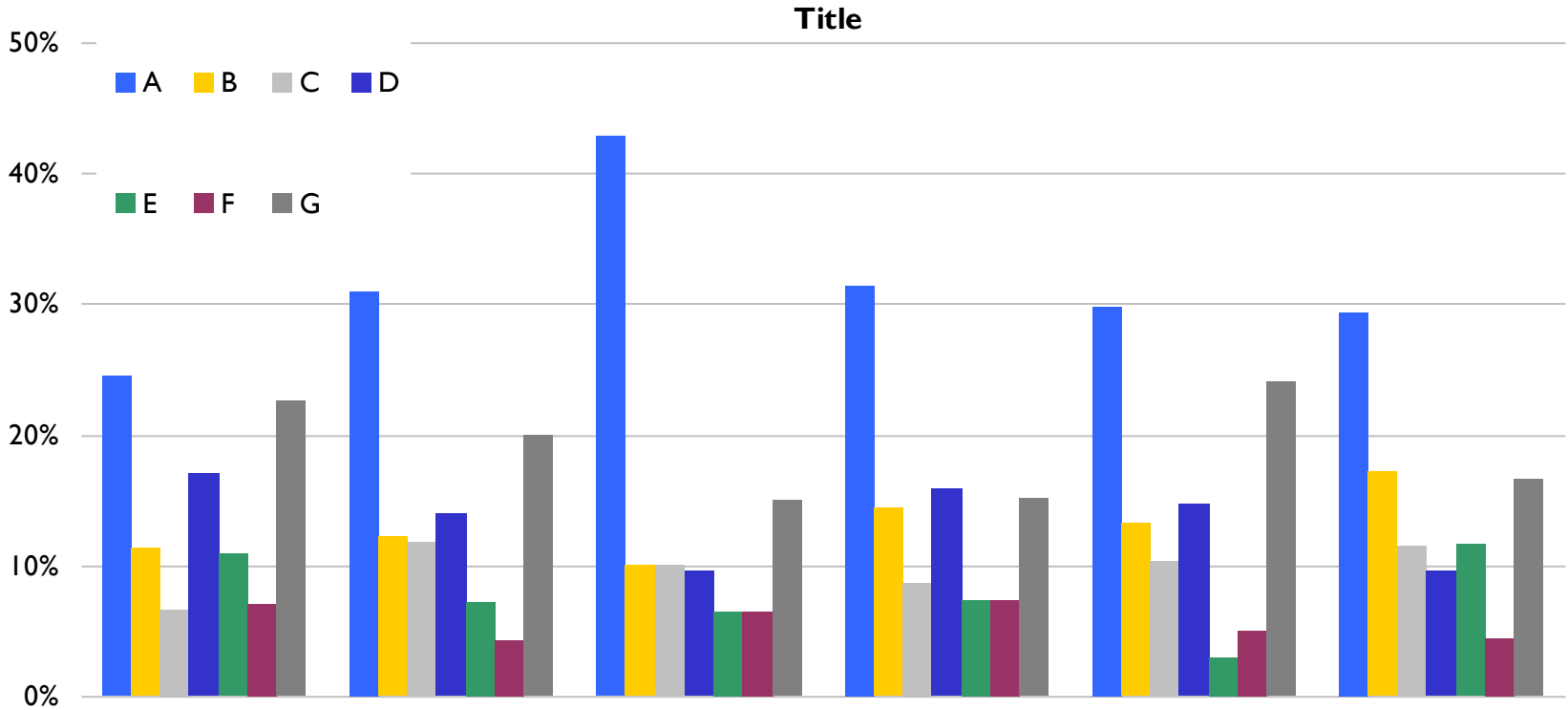

Charts: Multi-column

Title

ILLUSTRATIVE

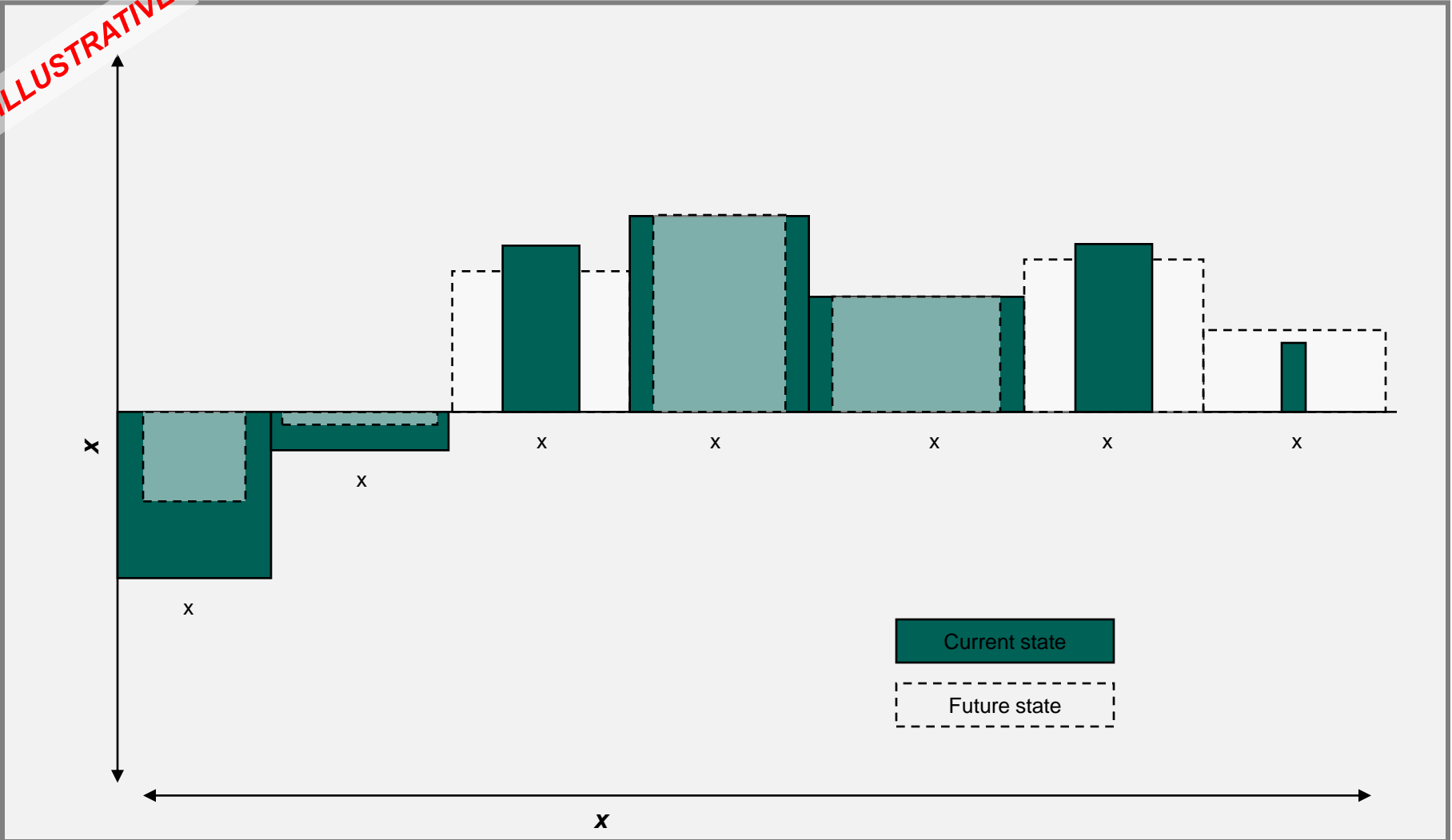

Charts: Waterfall

Title

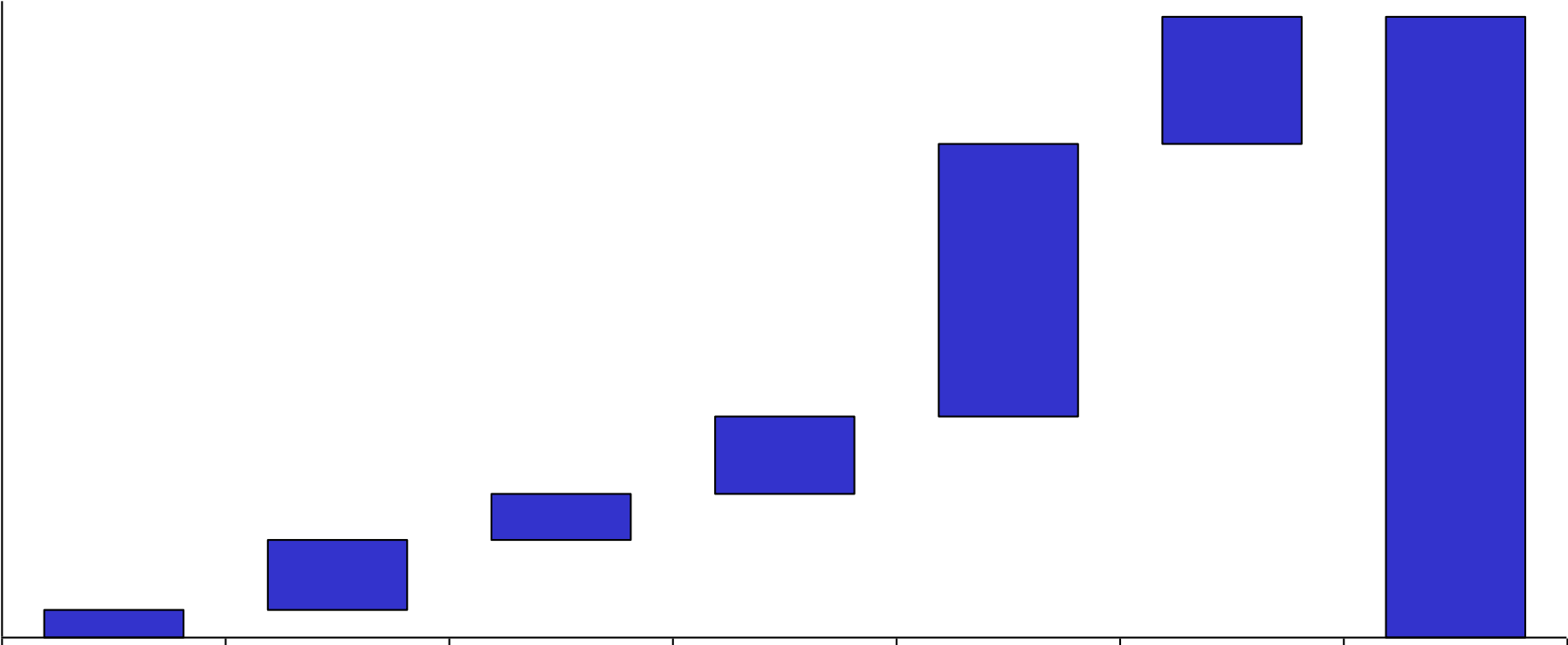

Charts: Radar

Cluster 1: 4%

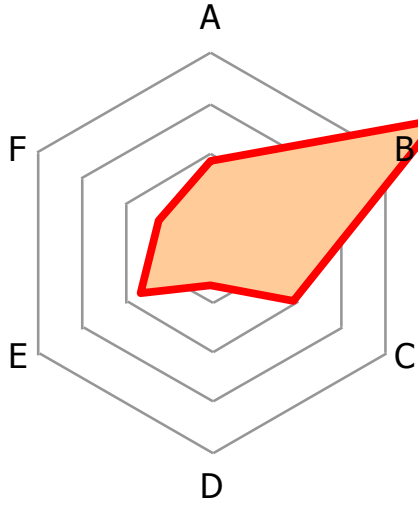

Cluster 2: 25%

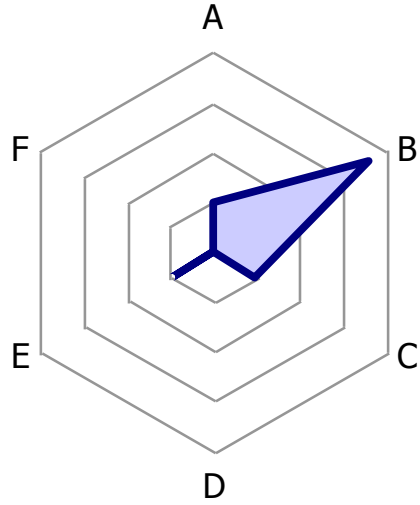

Cluster 3: 30%

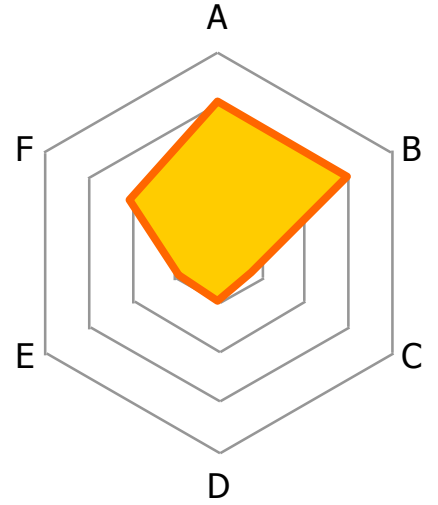

Cluster 4: 27%

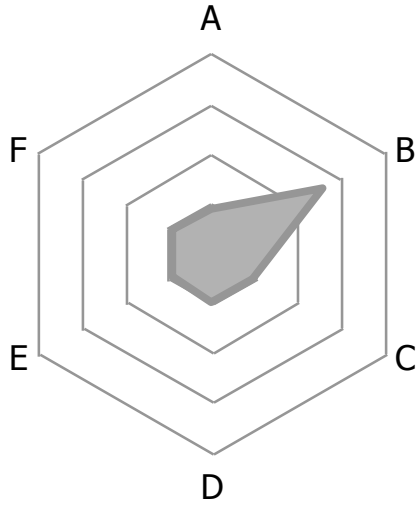

Cluster 5: 14%

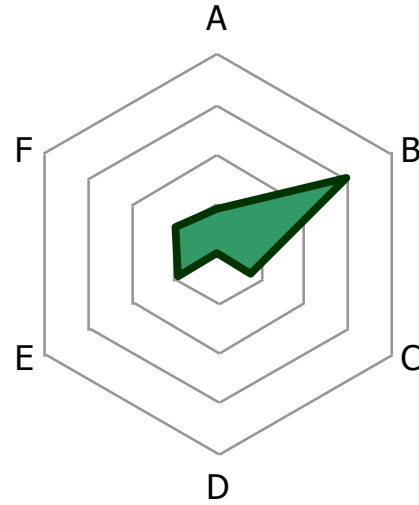

Charts: Area

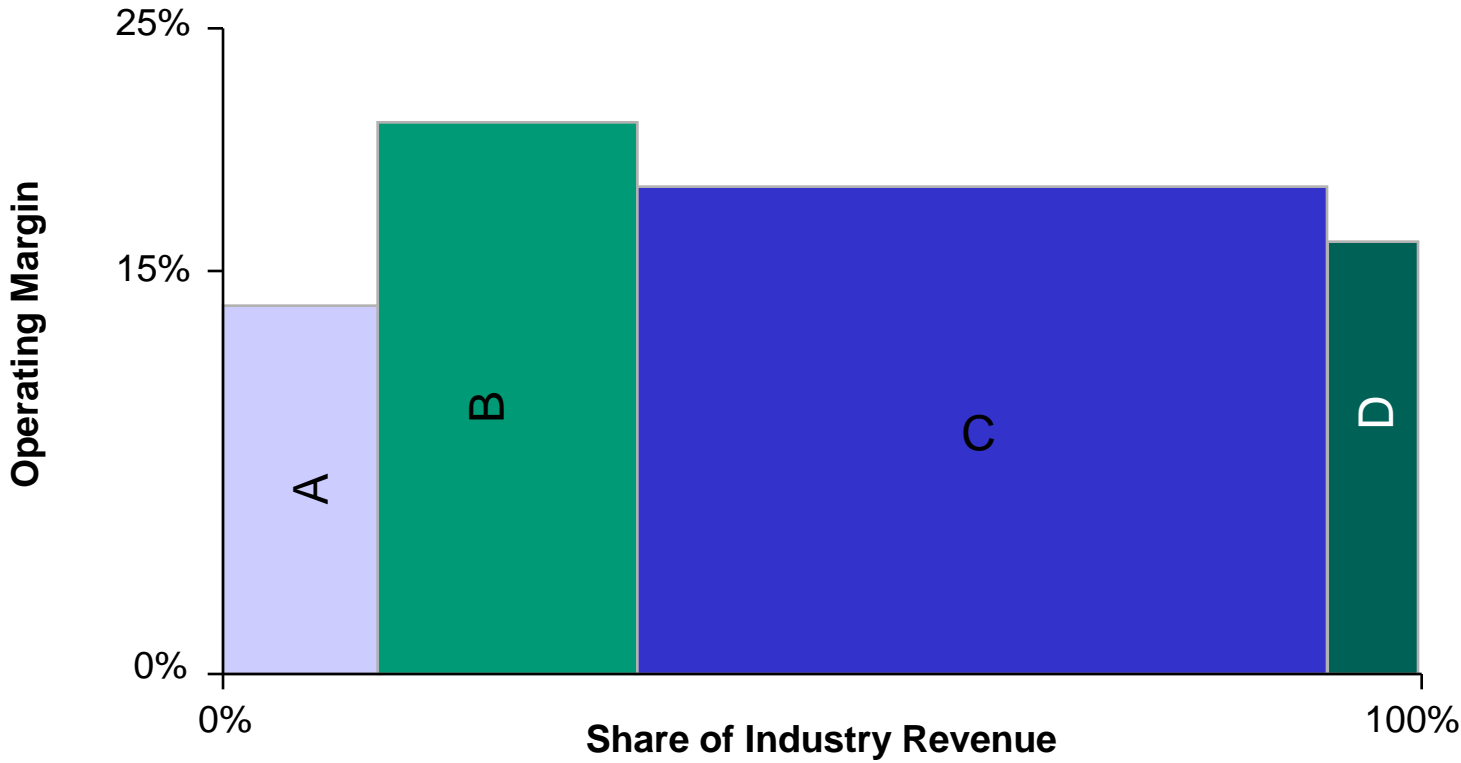

Charts: Column and Matrix

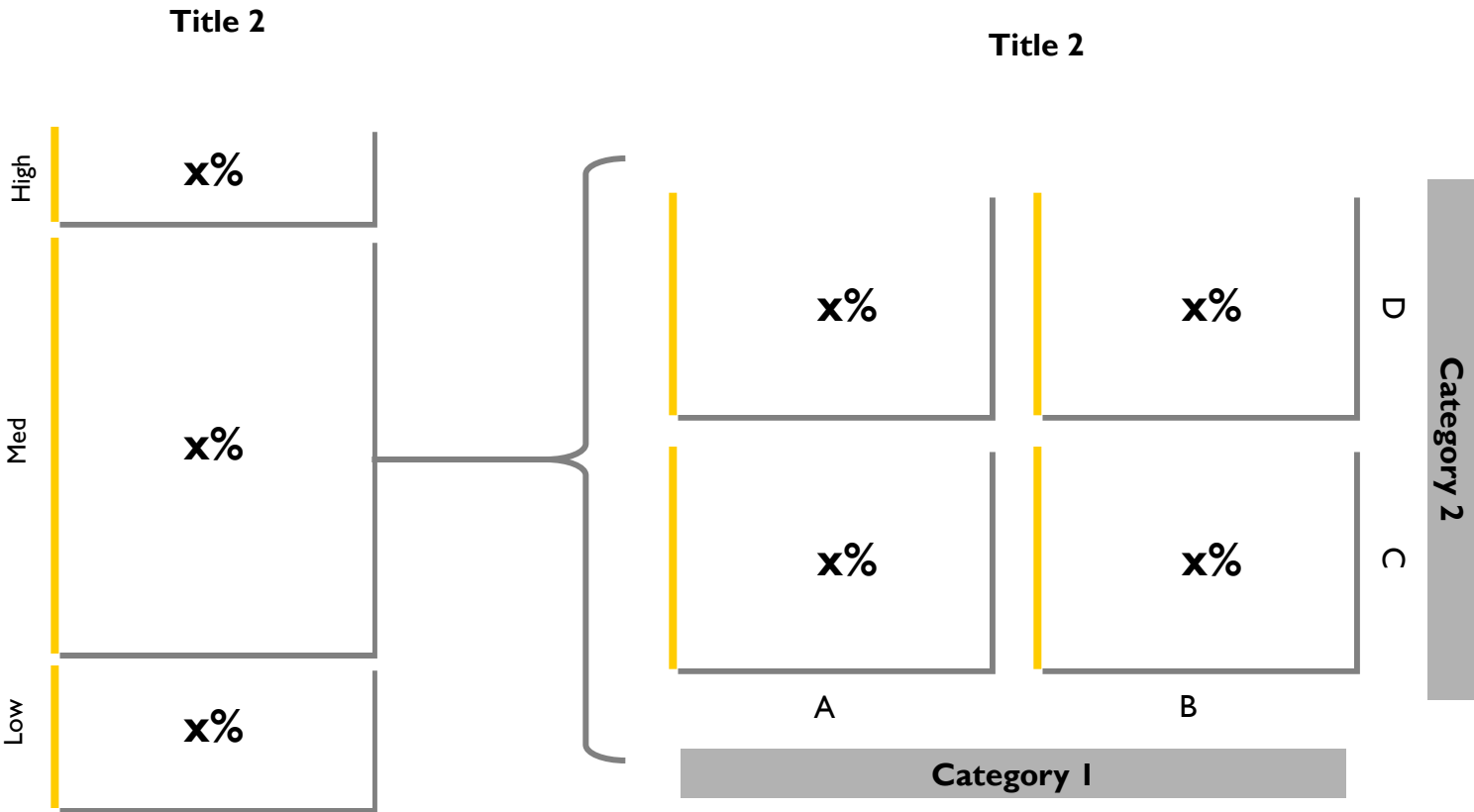

Charts: Line

Title

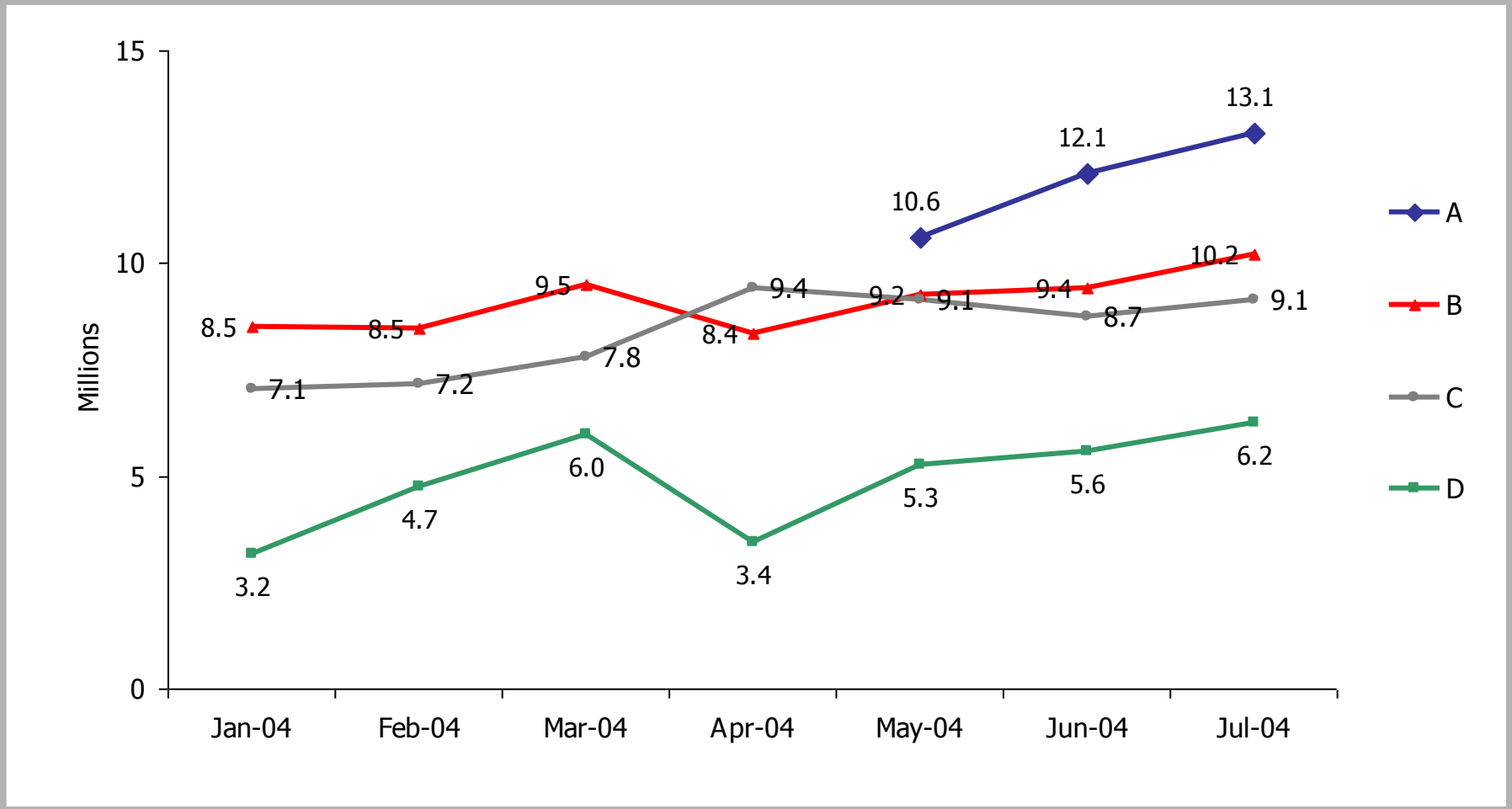

Outline

Widgets

Charts

Graphics

Slide structure

Graphic 1: Table

x	x	x
x	x	

Graphic 2: Value chain

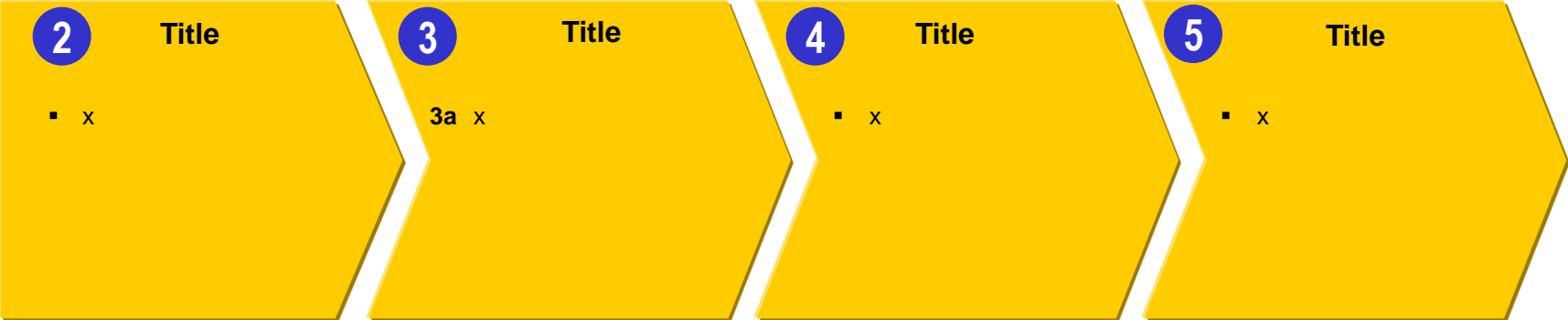

Graphic: Value chain with comments

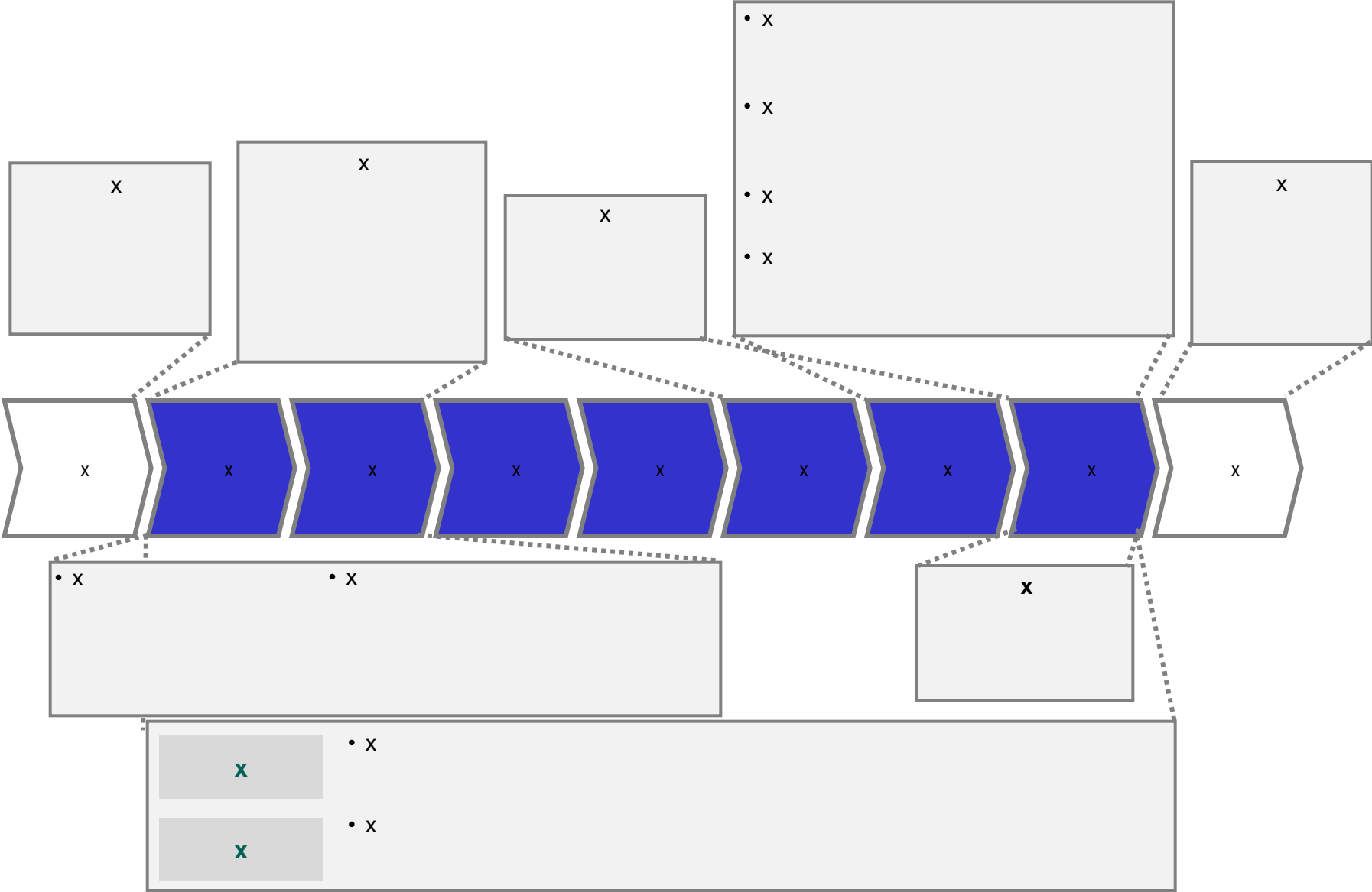

Graphic 2: Linked chain

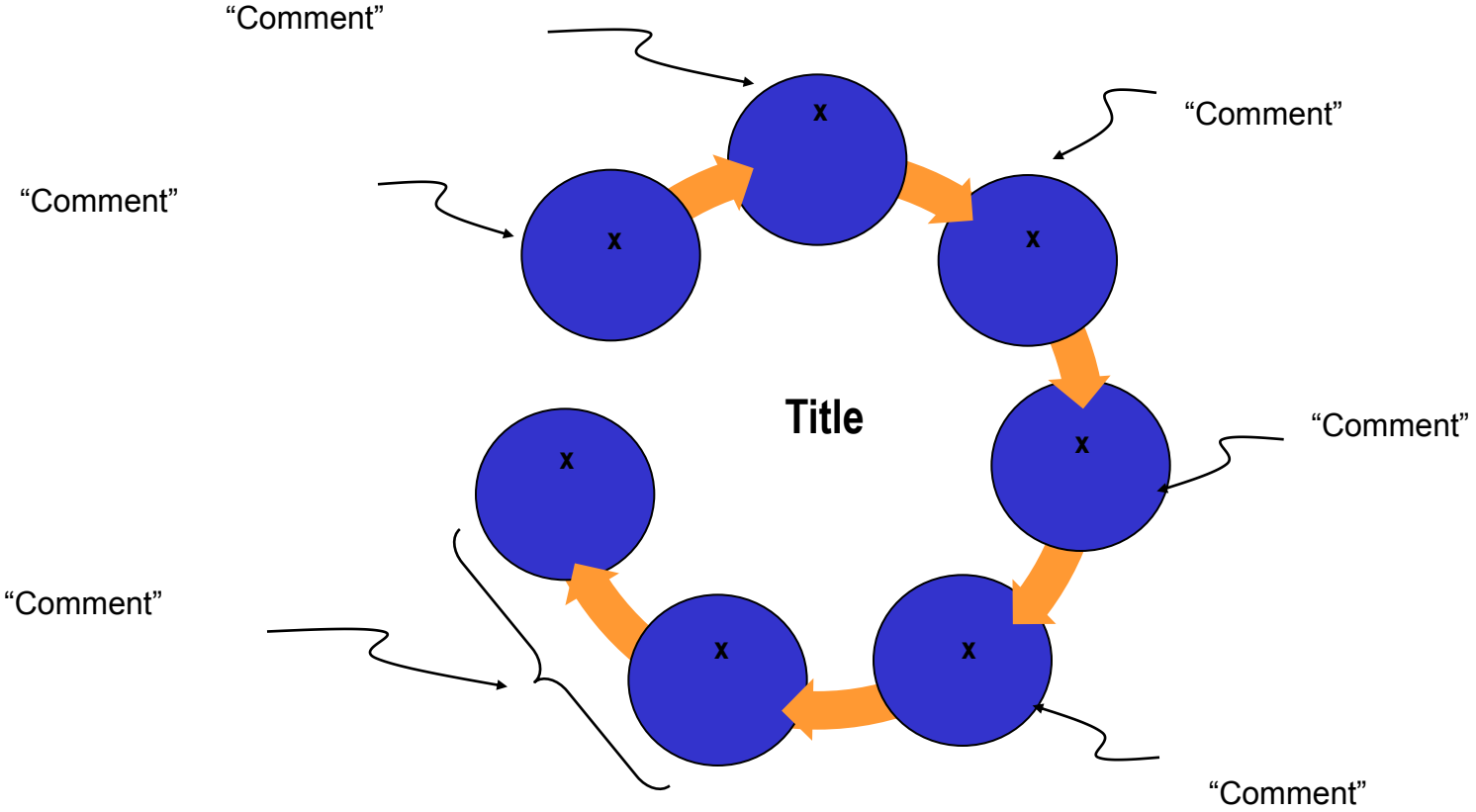

Graphic: Three dimensions

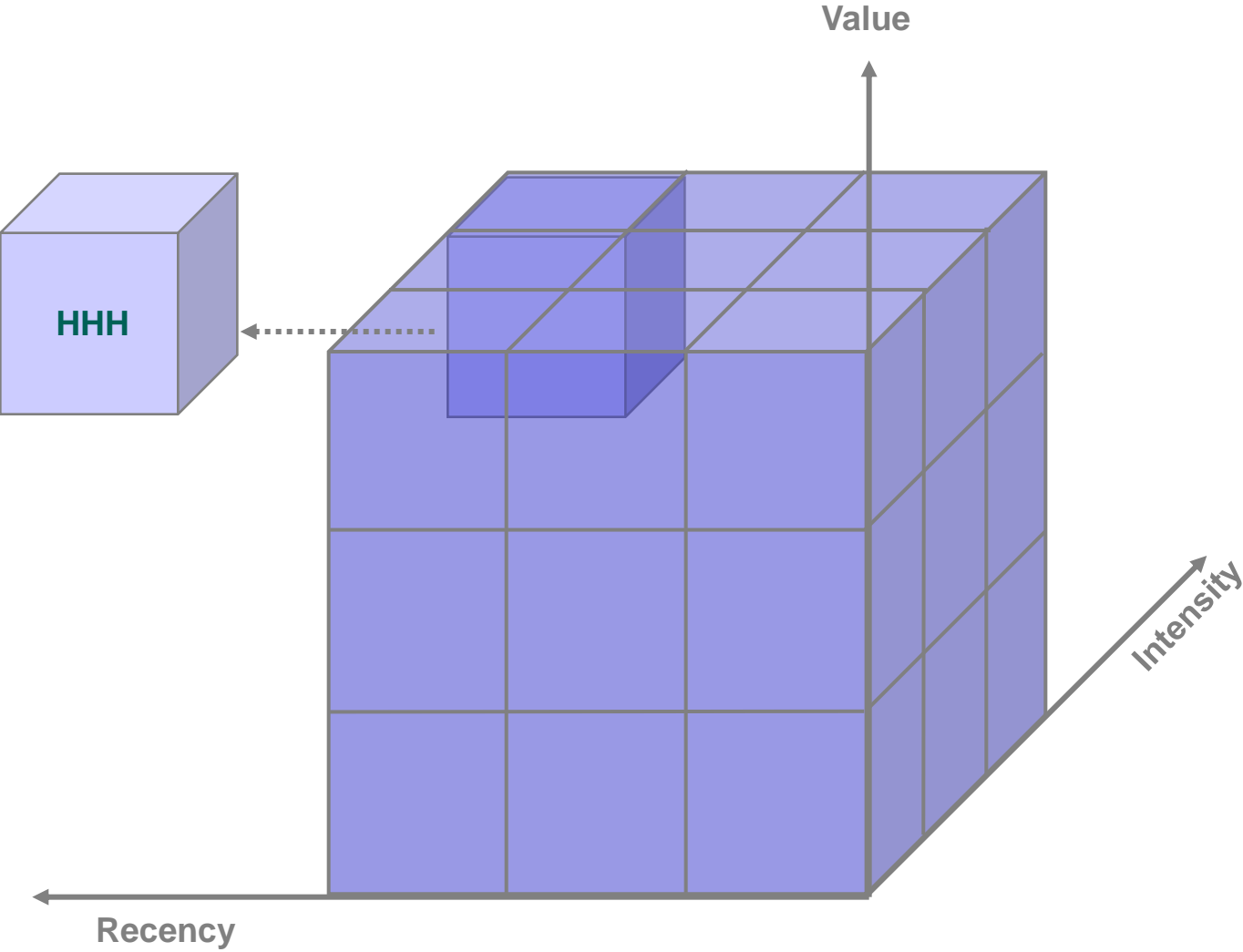

Graphic: Market forces

Force 1

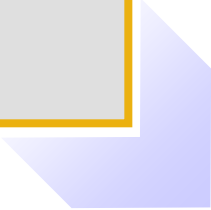

Force 2

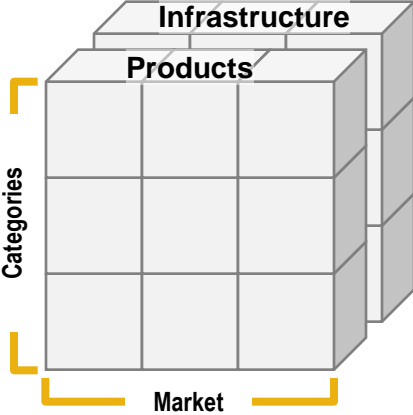

Force 4



Force 3



Graphic: Expanding impact

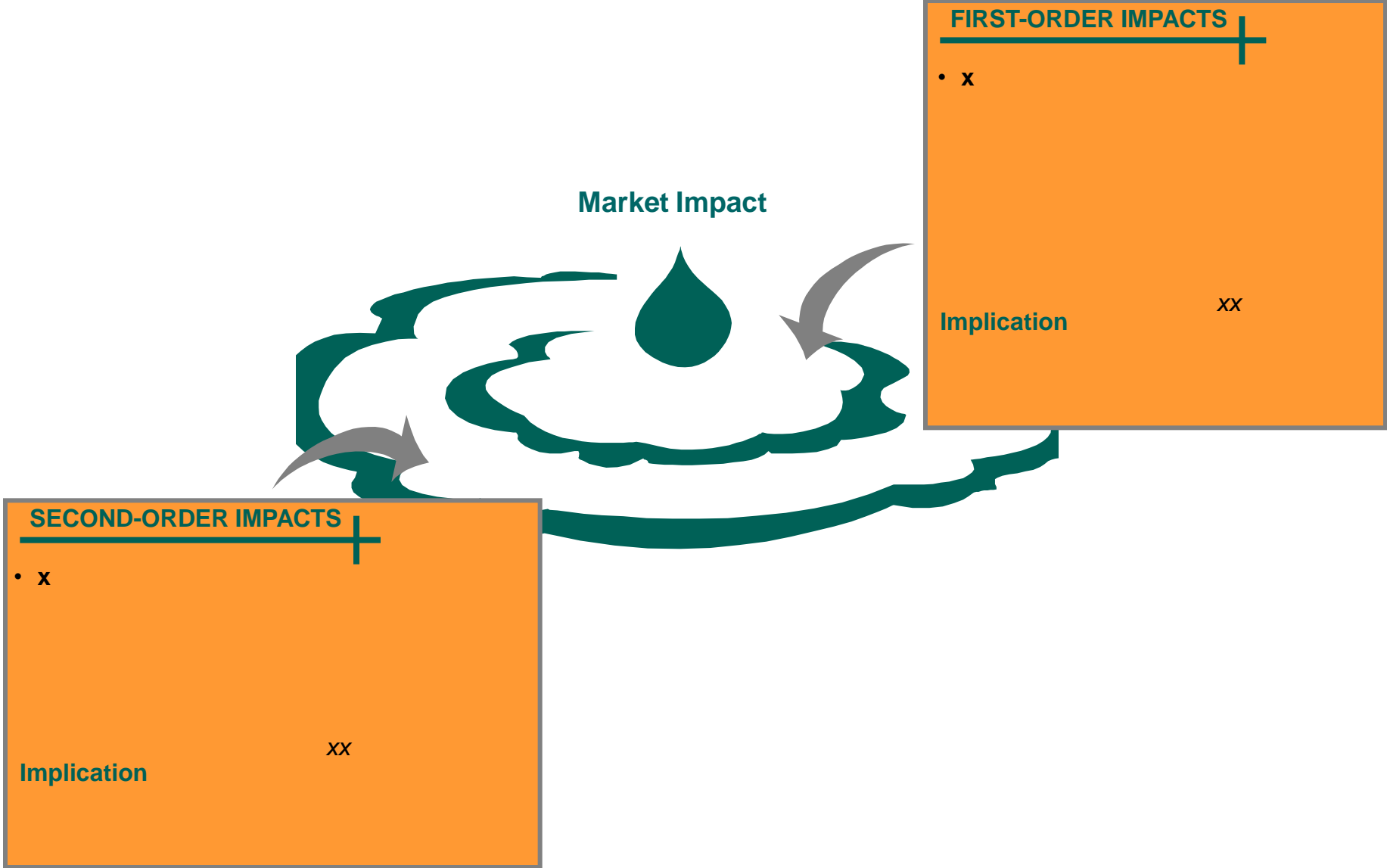

Graphic: Expanding area

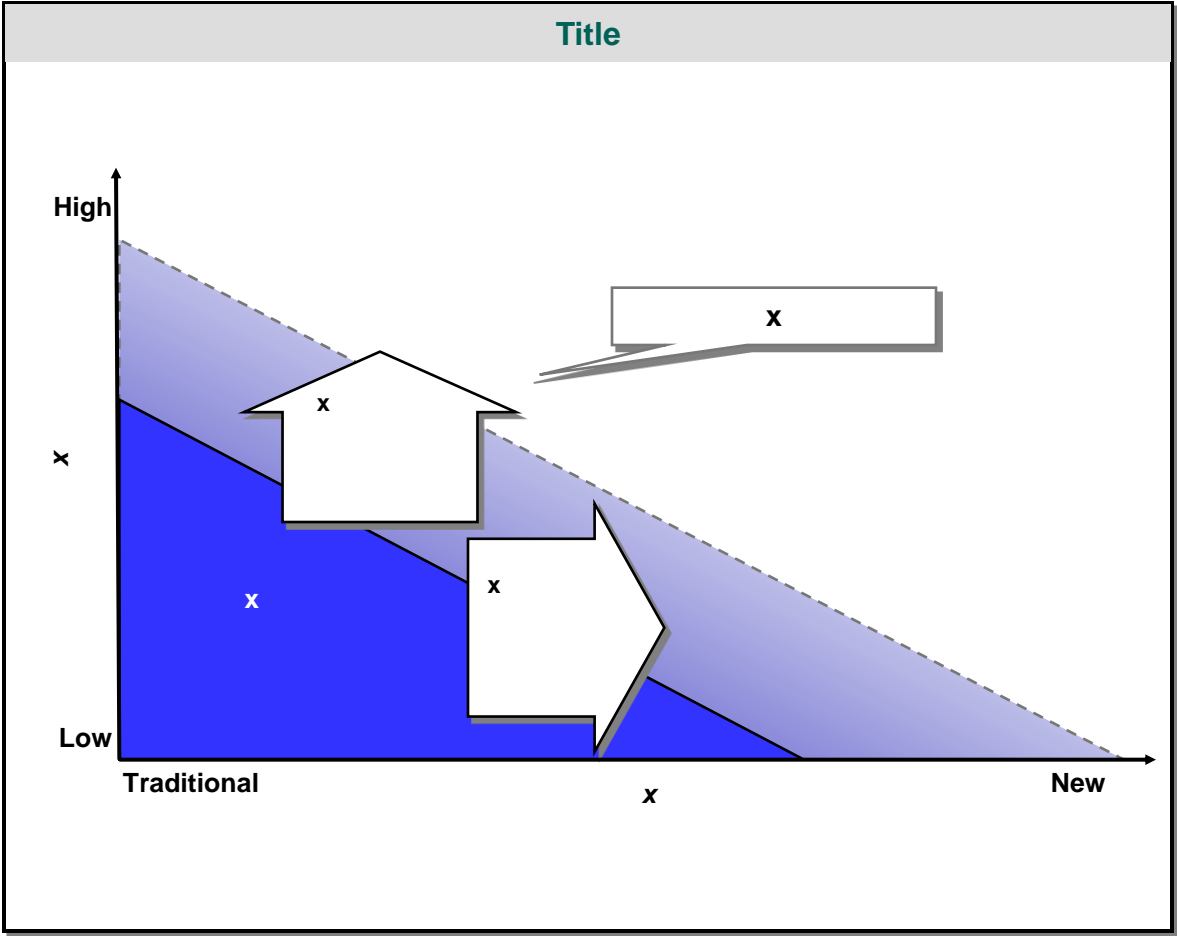

Graphic: Segmentation scheme

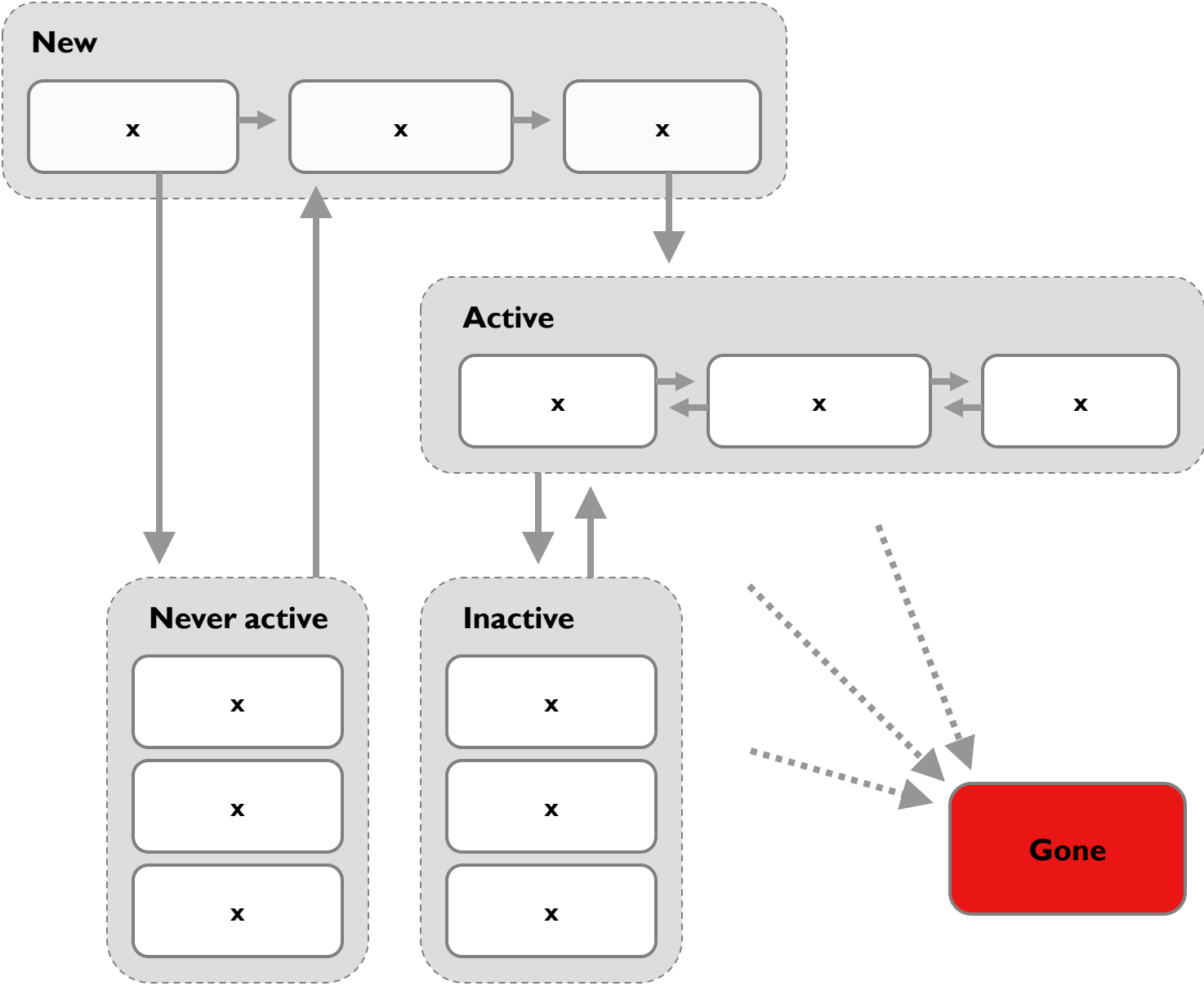

Graphic: Ranges

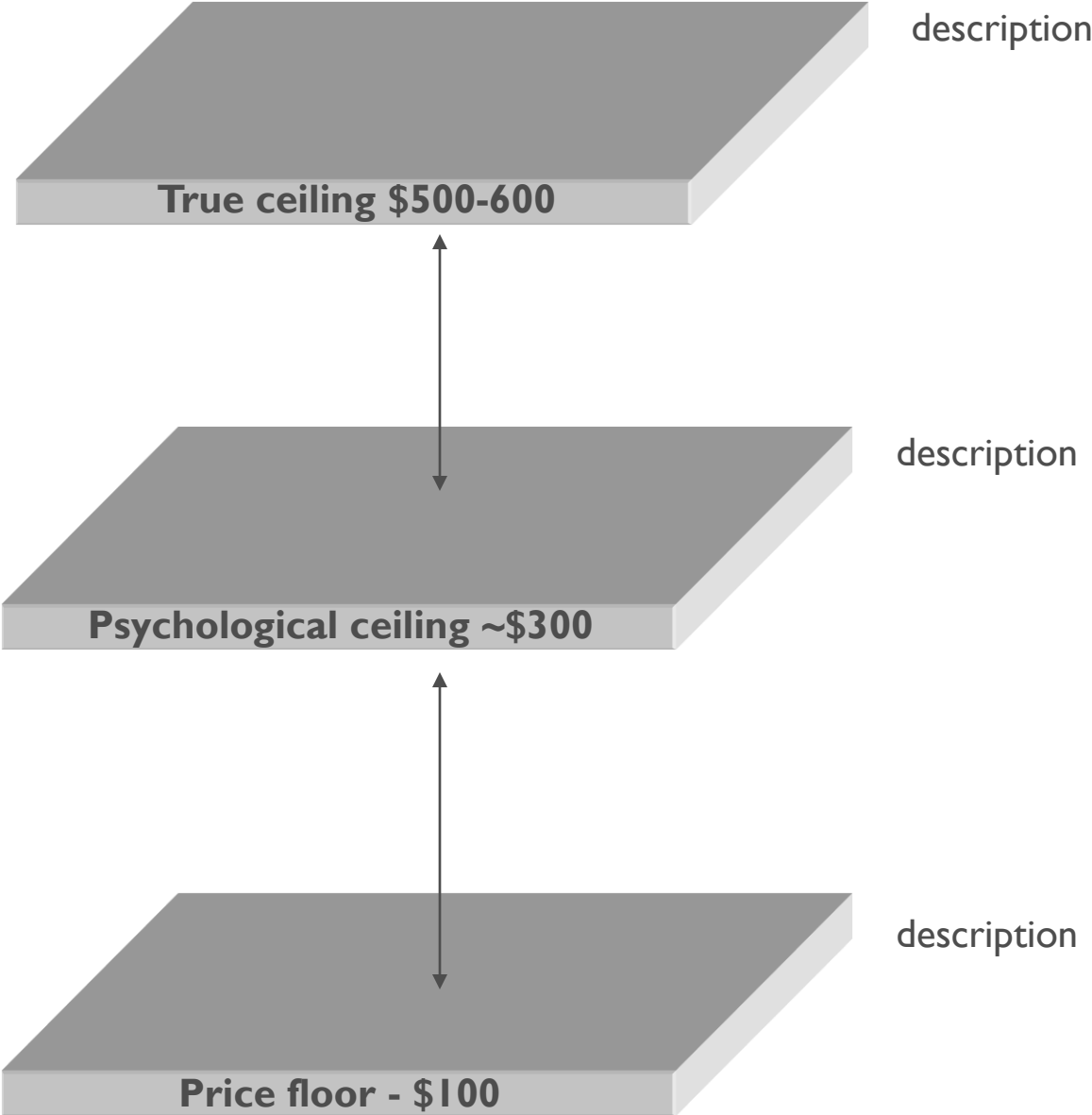

Graphic: Positives/negatives



- Positives I
 - Subpoint
- Positive 2
 - Subpoint
- Positive 3



- Negative I
 - Subpoint
- Negative 2
 - Subpoint

Graphic: Product roadmap

Extension B

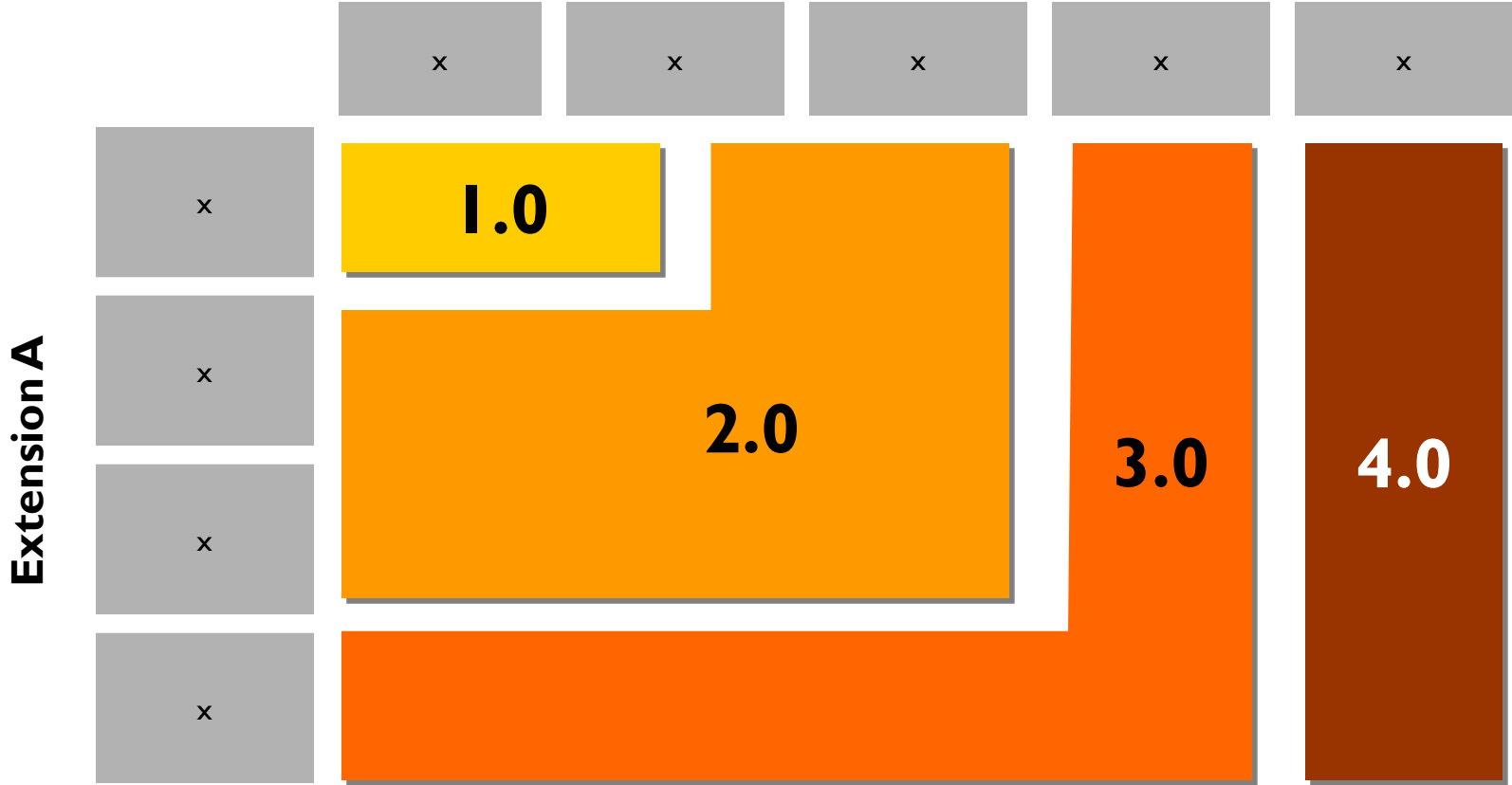

Graphic: Flows

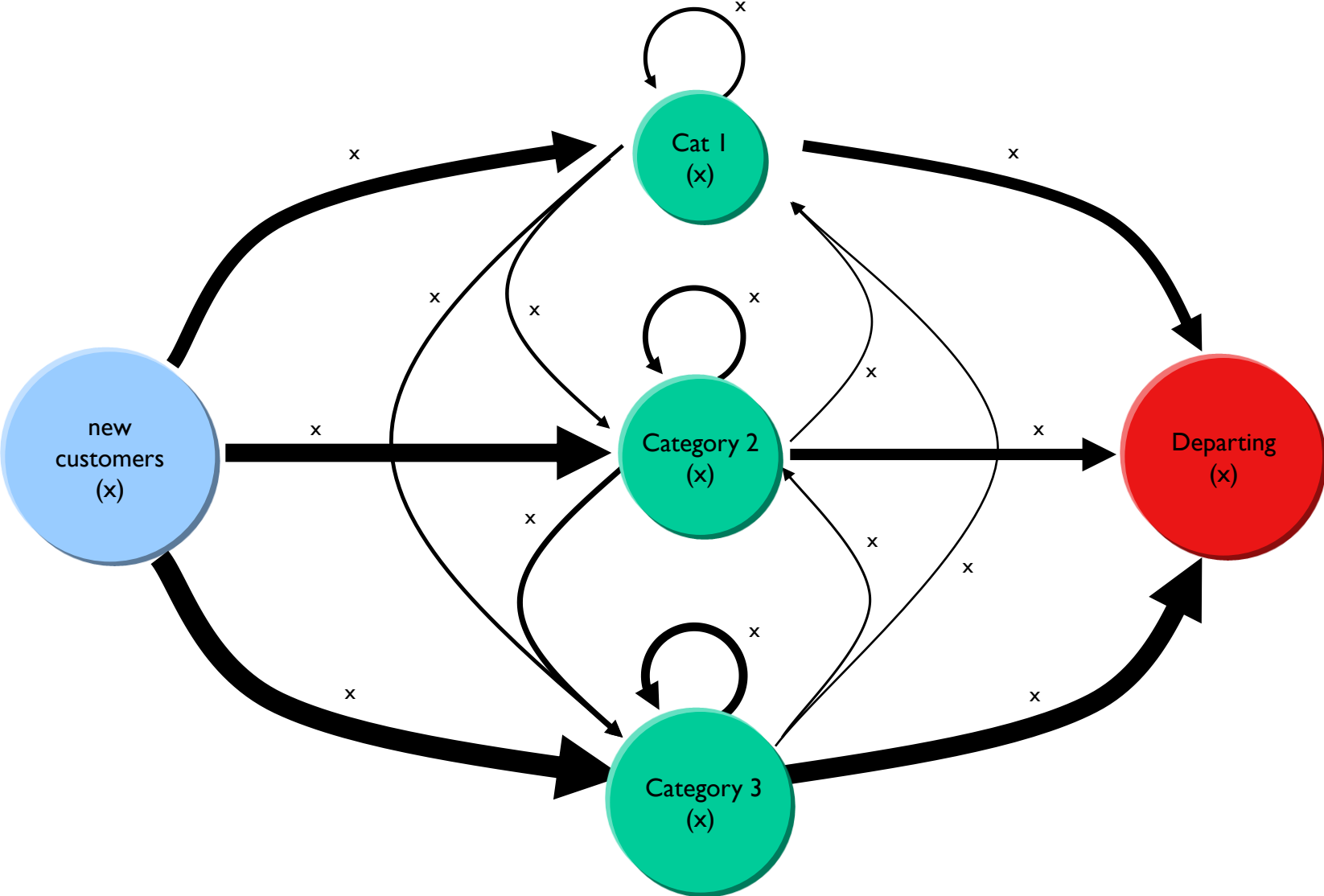

Excludes course trialers

Graphic: Process

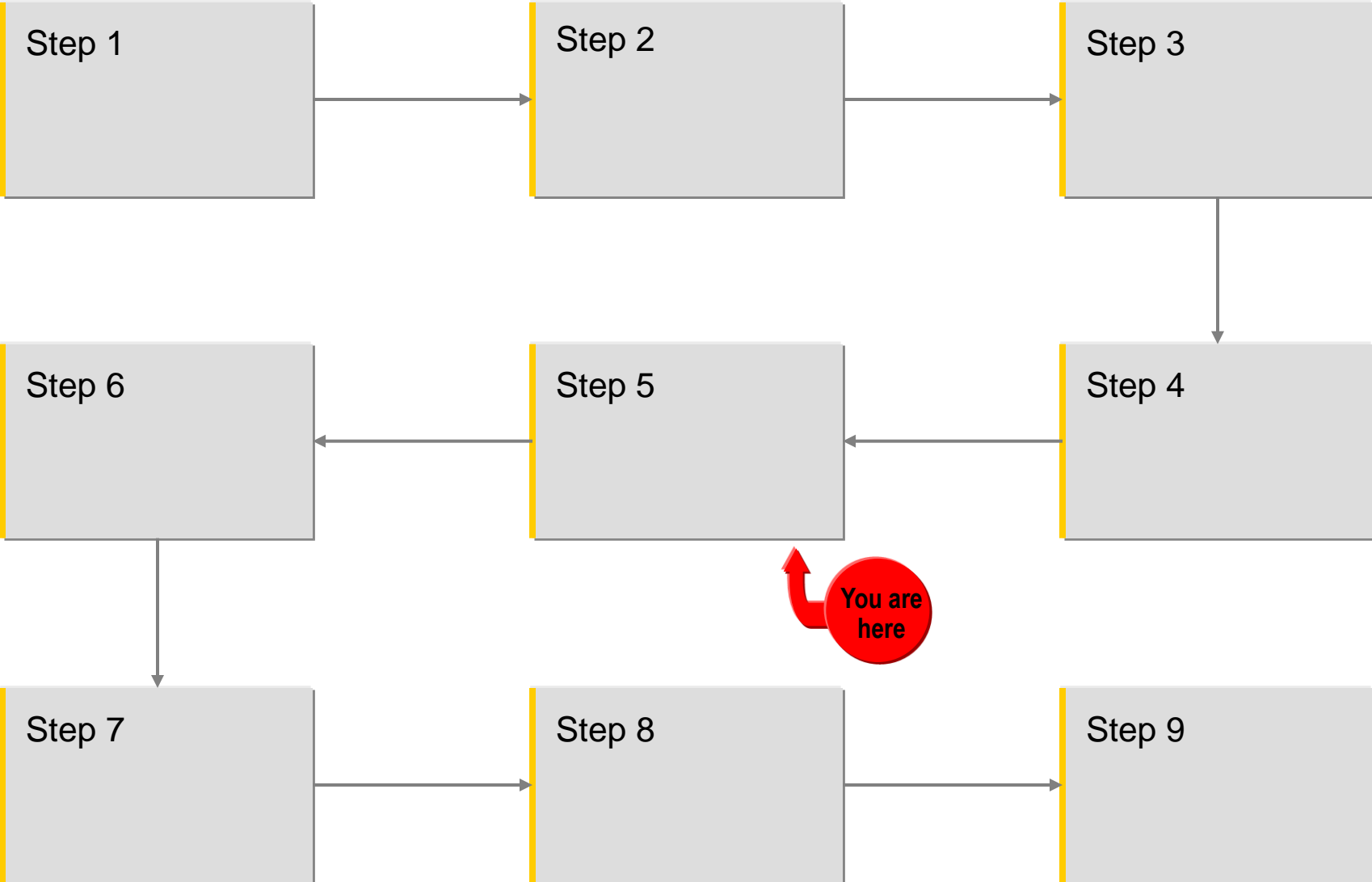

Graphic: Venn diagram

Title

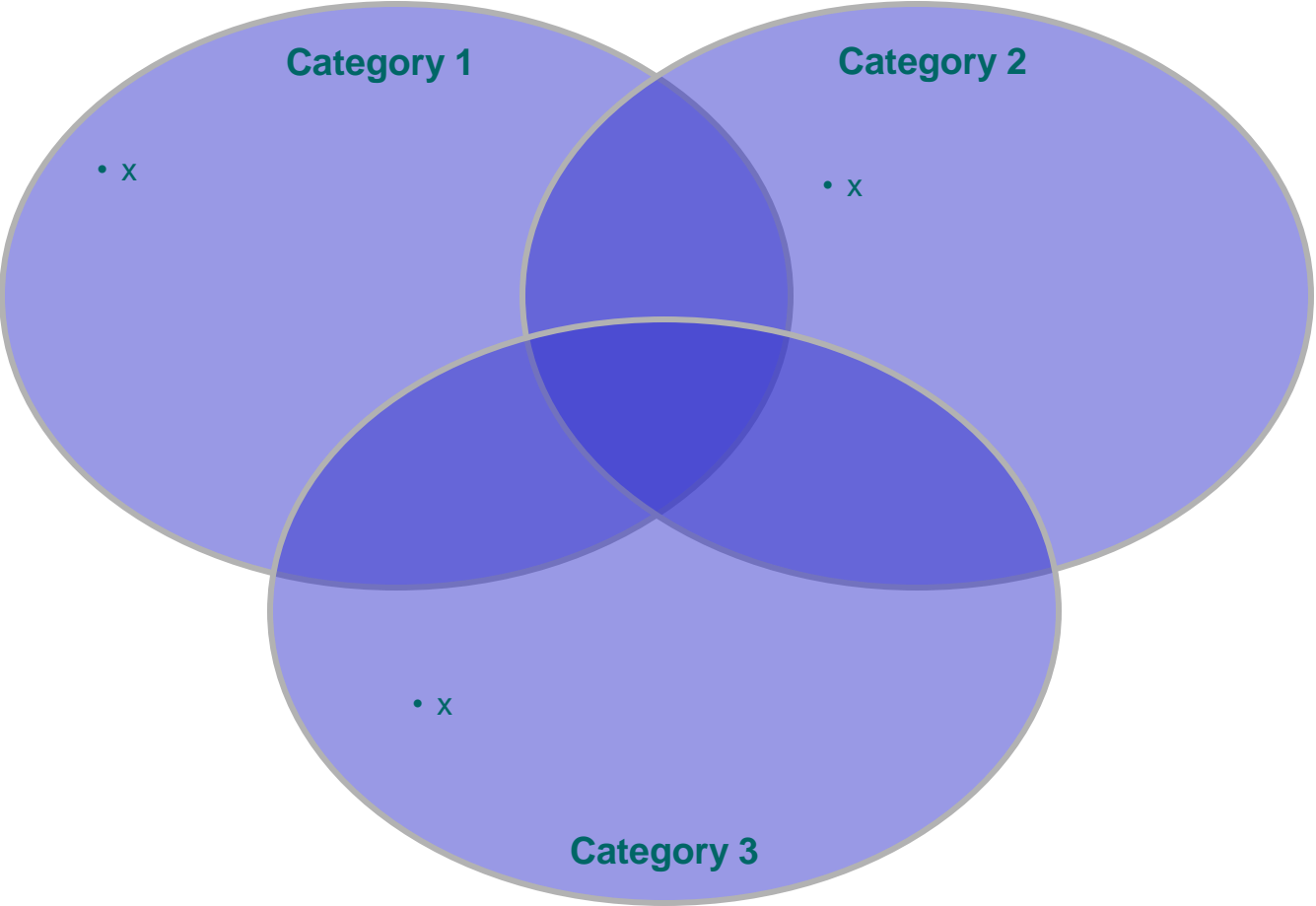

Graphic: Pyramid concept

Title

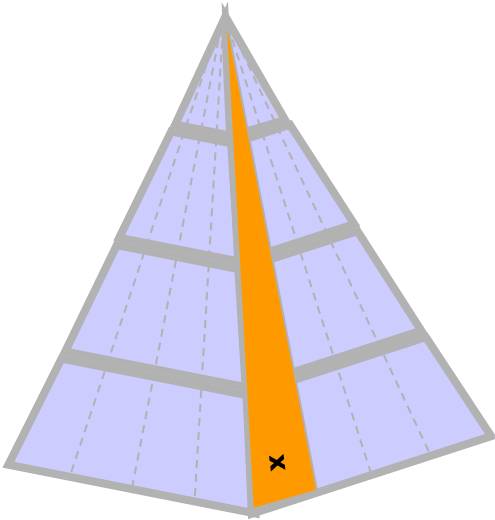
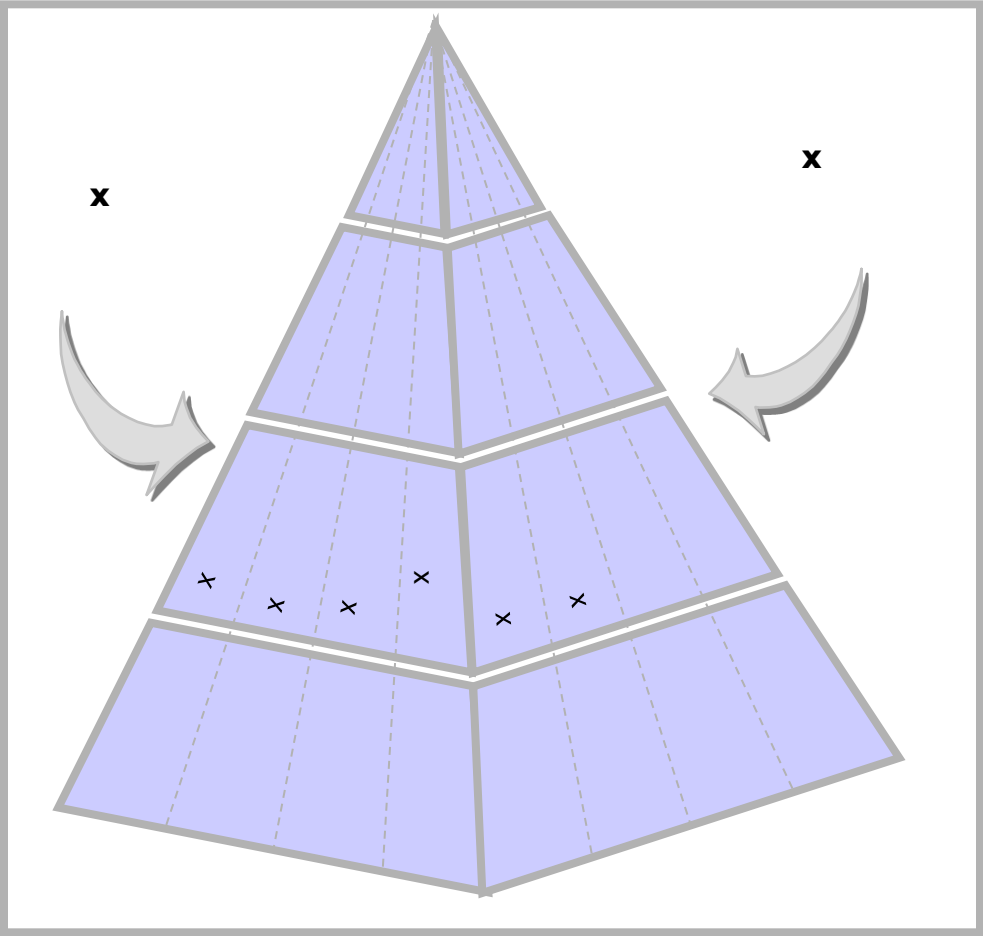

Graphic: Filtering of opportunities

Long list

- X
- X
- X
- X
- x

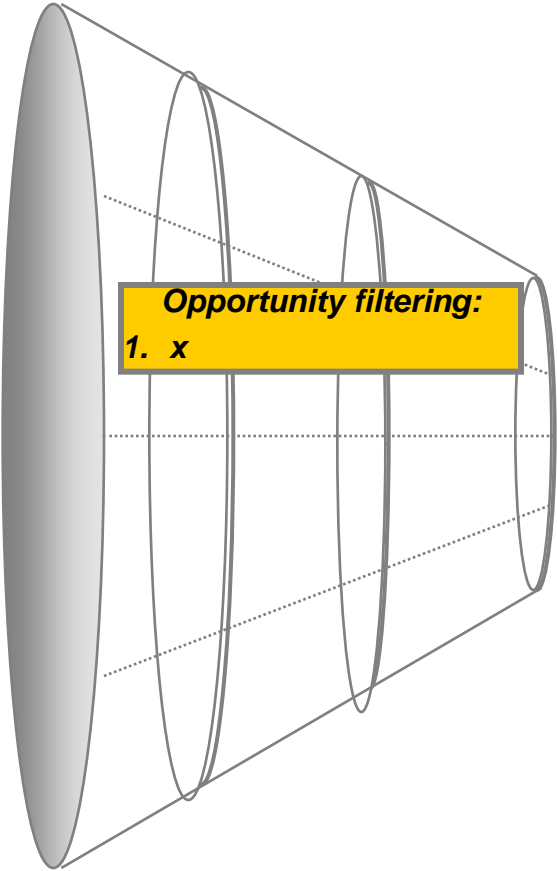

Potential Opportunities

- X

- X
- X
- x

[]

[]

Graphic: Market space

Title

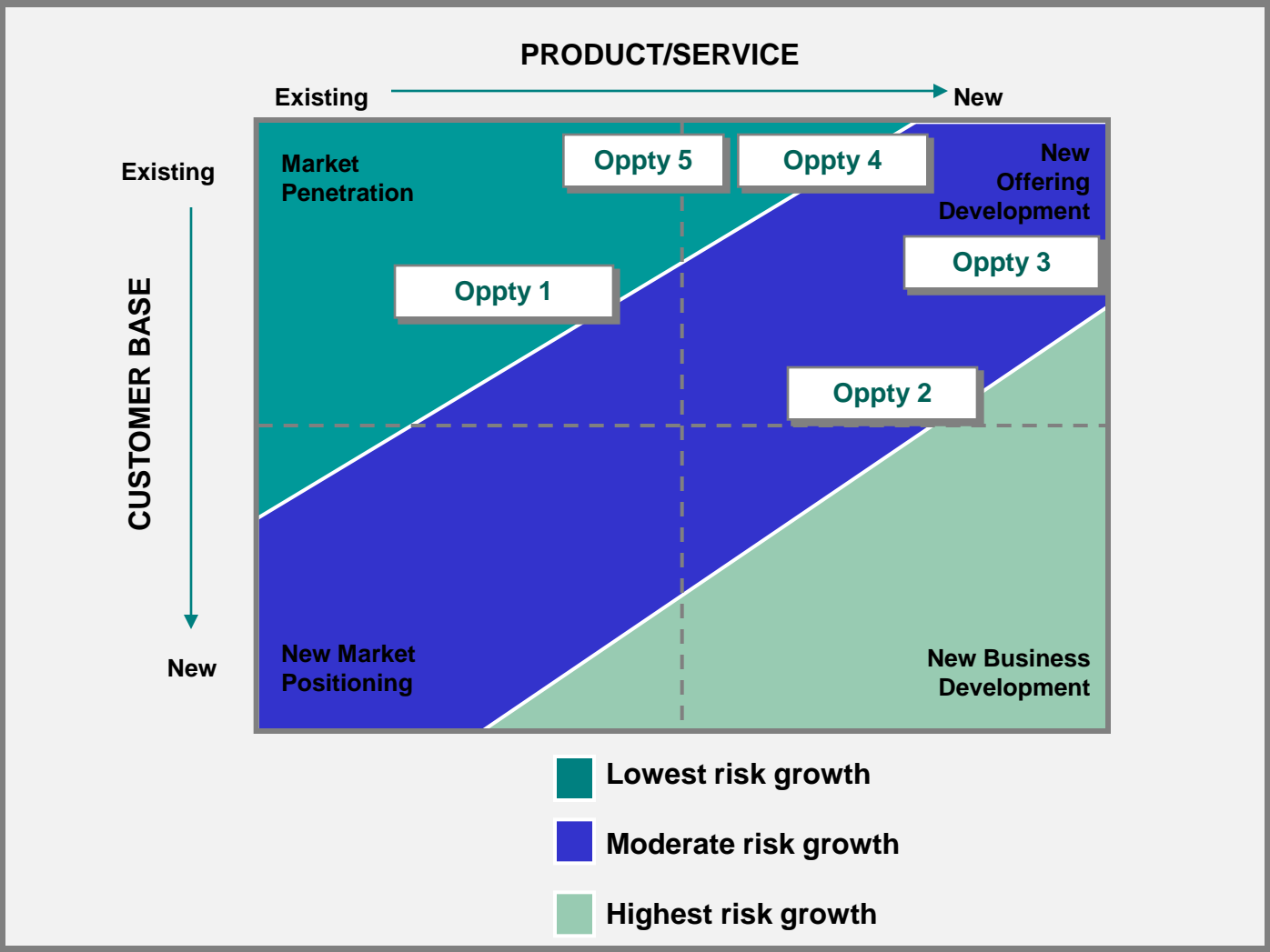

Graphic: Market space

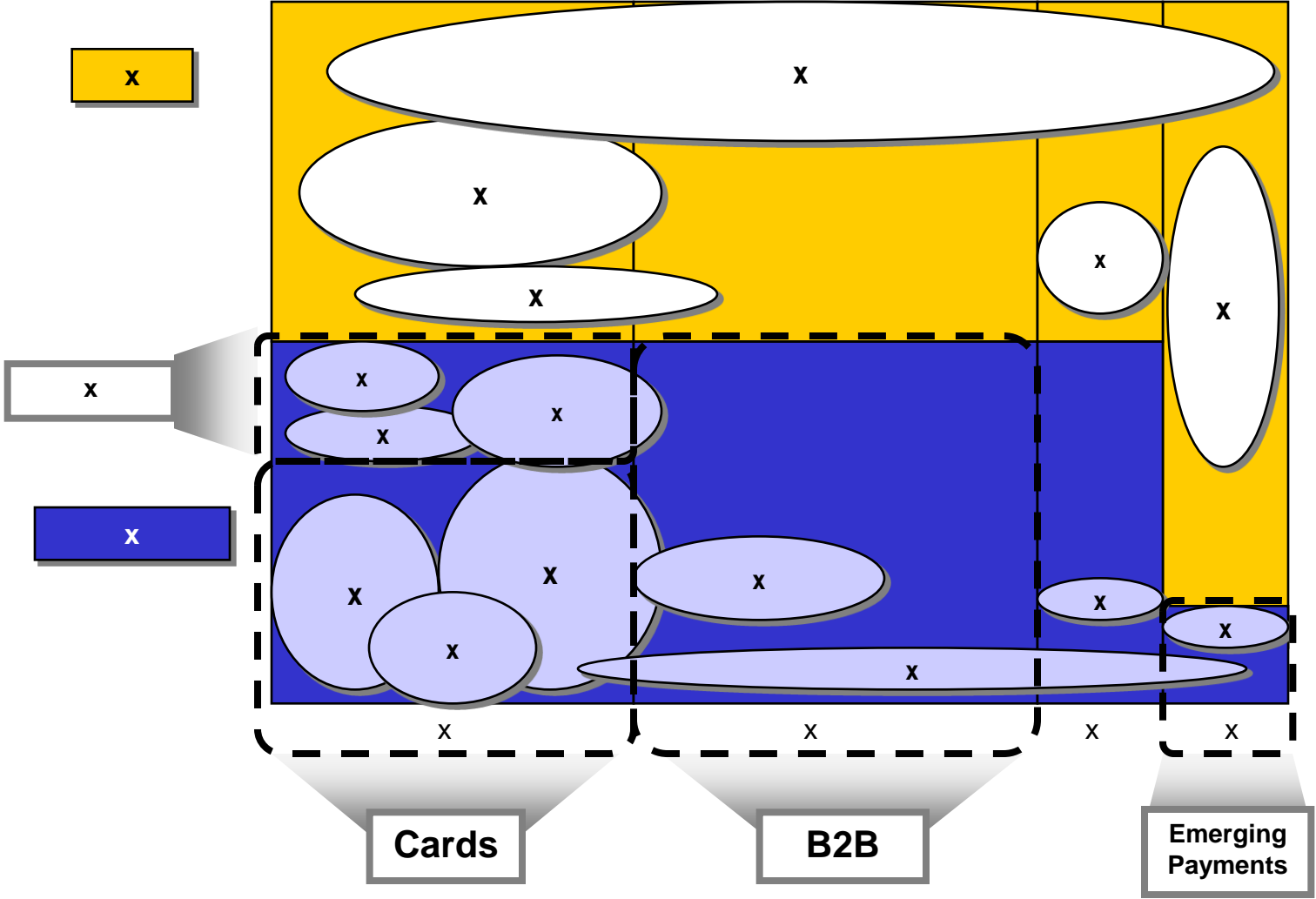

Graphic: Project timeline

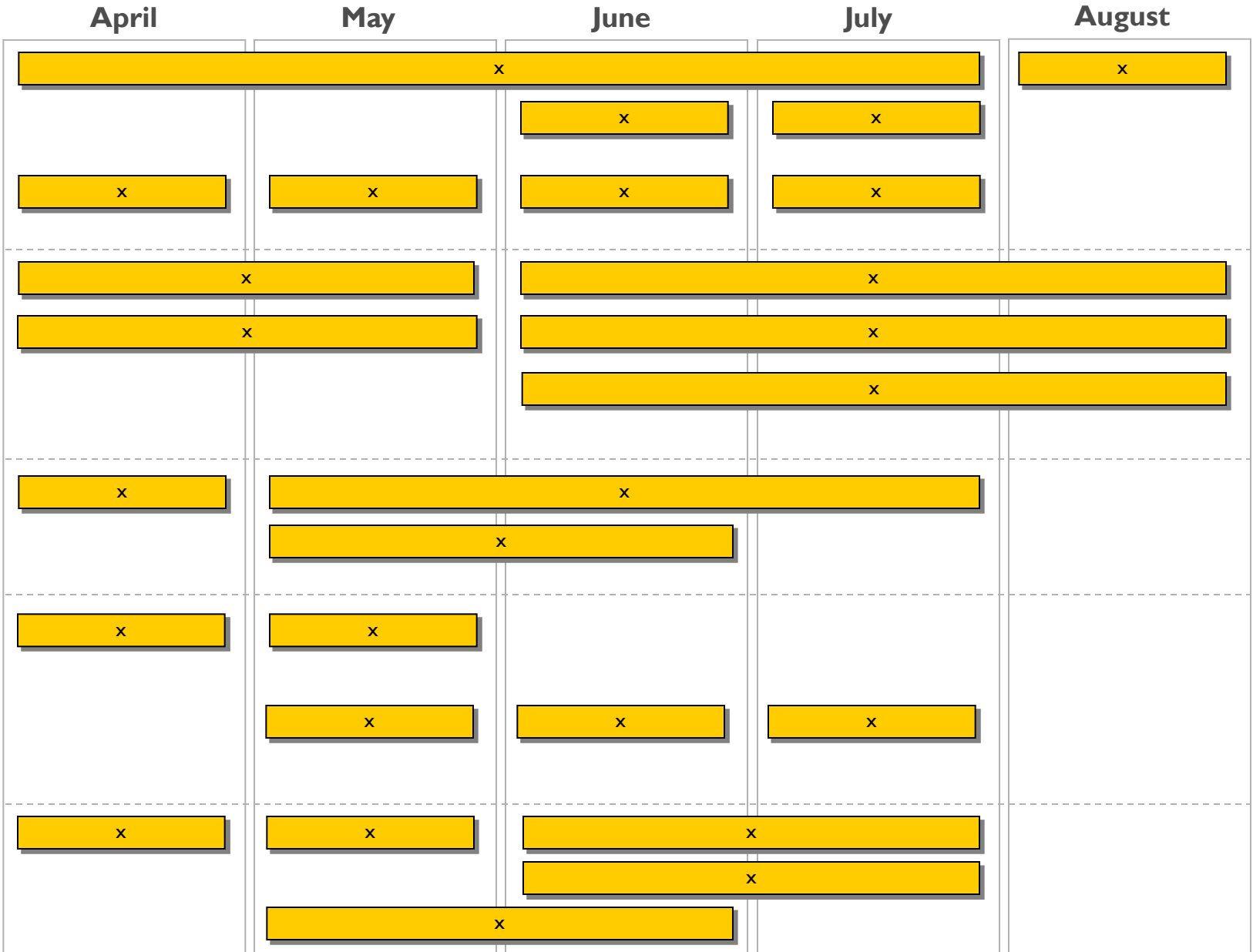

Graphic: Project timeline

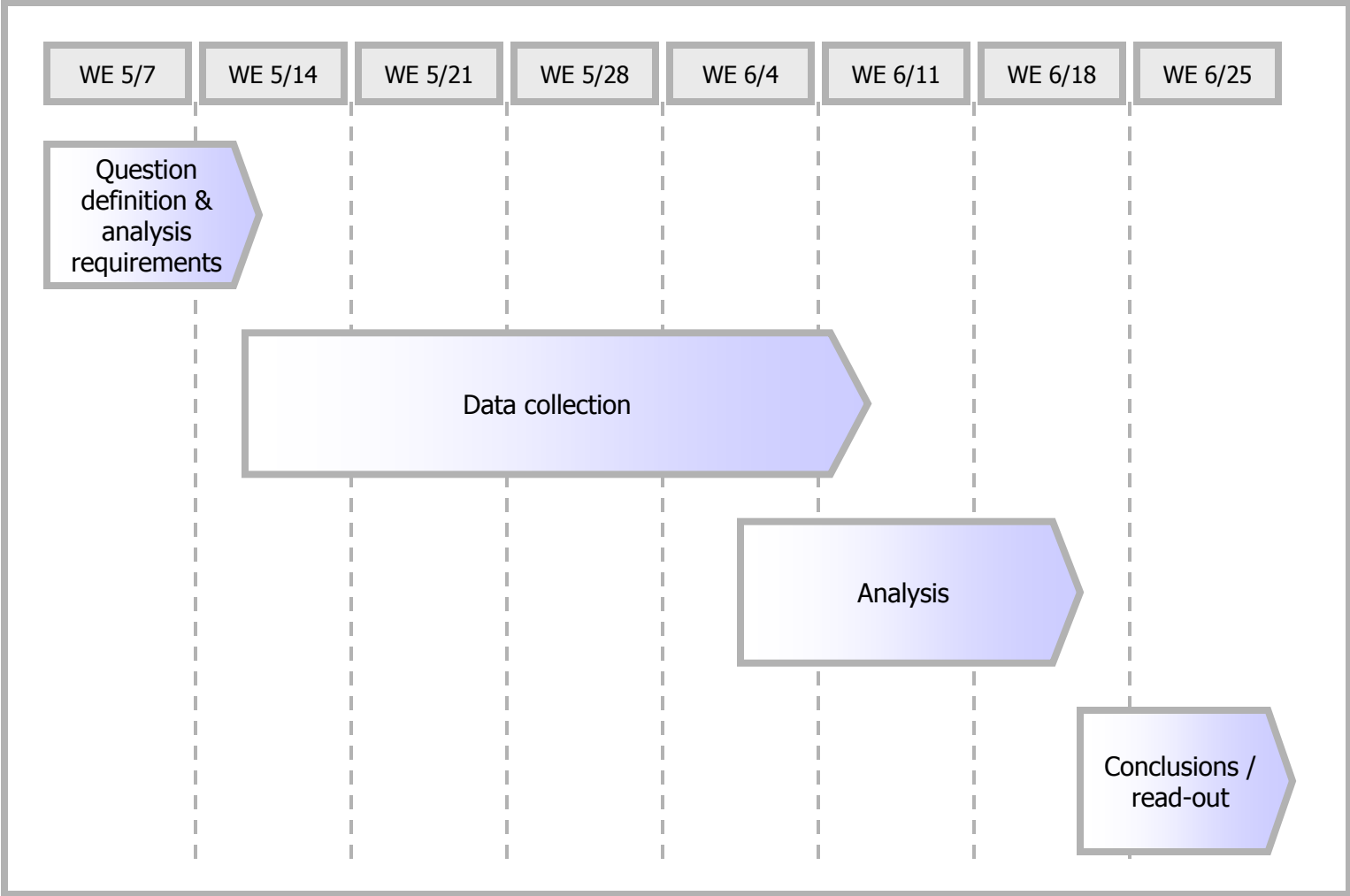

Graphic: Value chain table

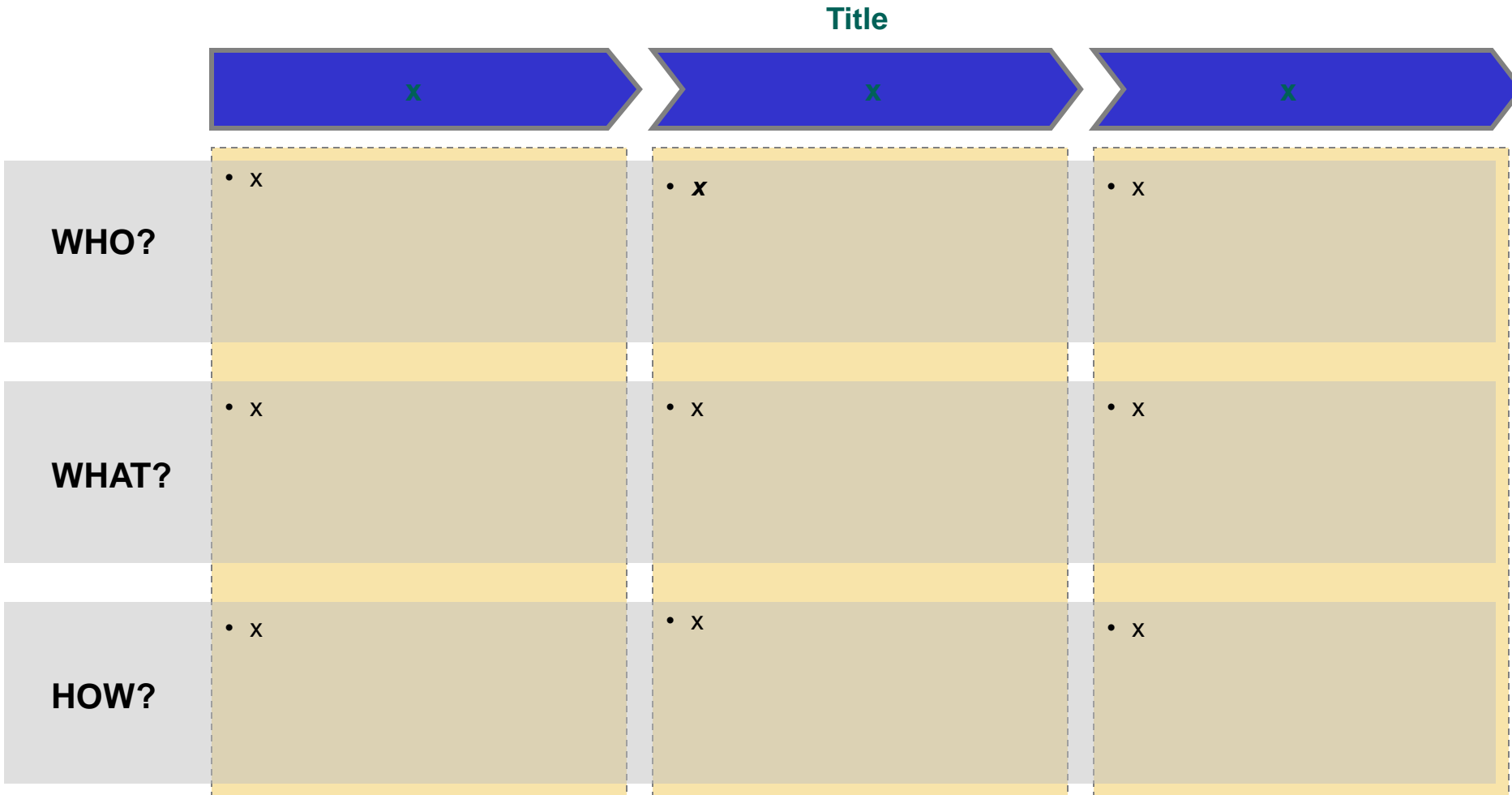

Graphic: Consulting proposal

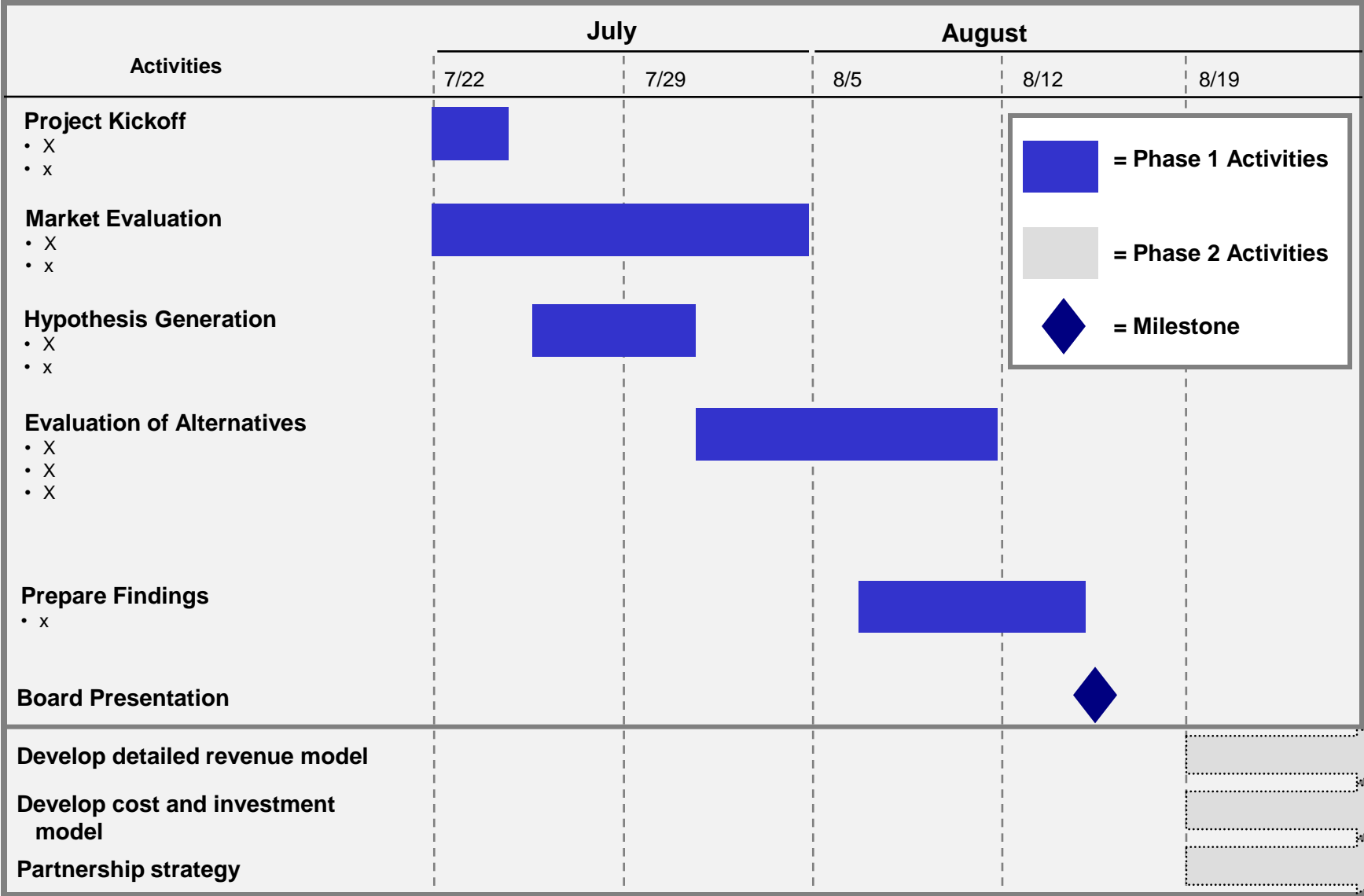

Outline

Widgets
(subheader)

Charts
(subheader)

Graphics
(subheader)

Slide structure
(subheader)

THE FOLLOWING **SHORT FILM** HAS BEEN APPROVED FOR
[AUDIENCE]
BY THE MOTION PICTURE ASSOCIATION OF AMERICA

THE FILM HAS NOT BEEN RATED

Slide structure...

Use this space to make a
bold statement and change
the pace of the presentation

Slide structure: Chart and description

Header

Title

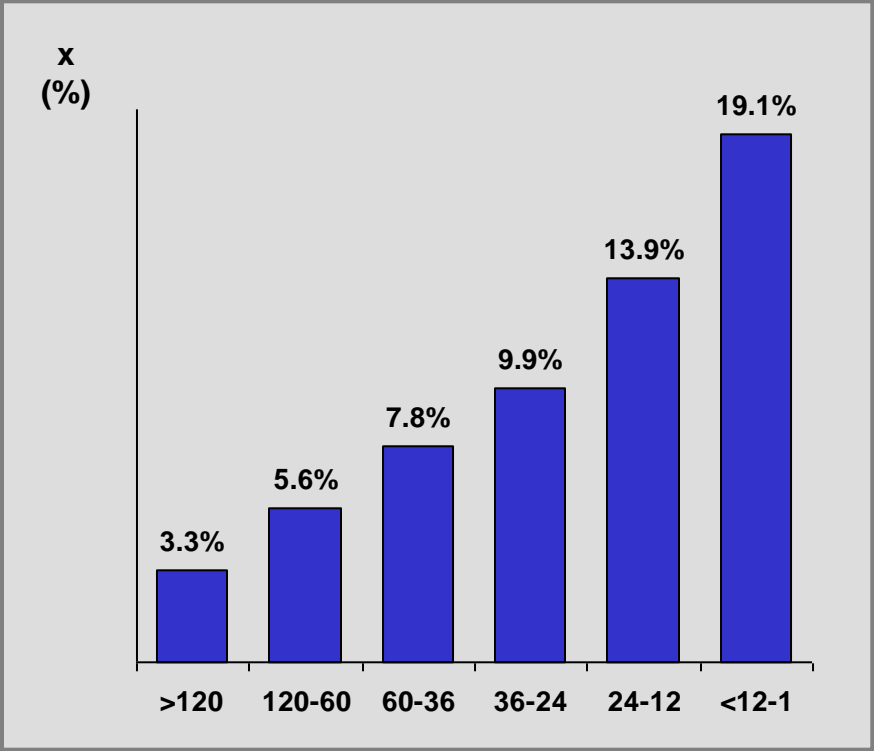

Title

- X
- X
- x

“Kicker quote”
Source

Slide structure: Two charts with headlines

Header 1

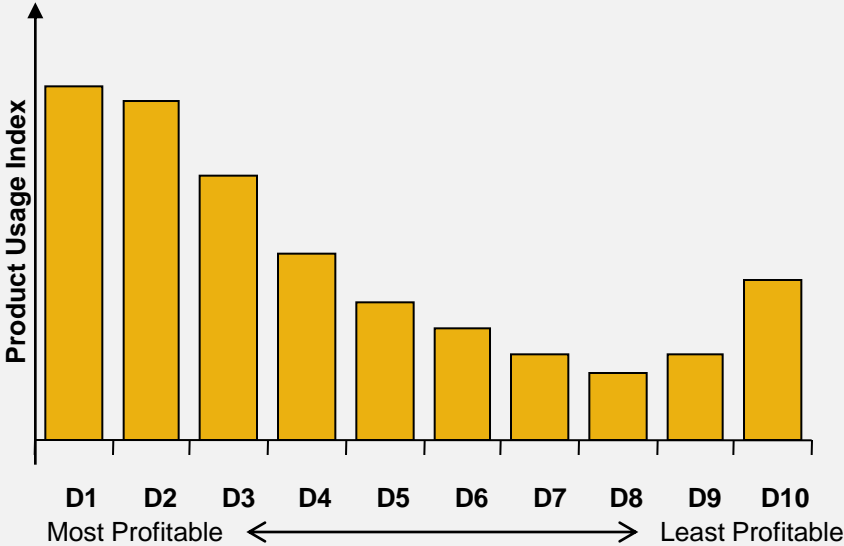

Header 2

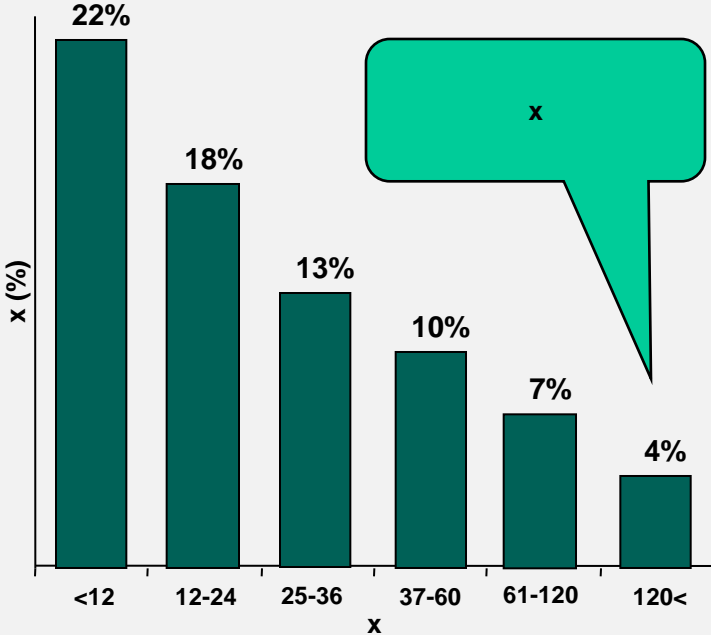

Kicker

Slide structure: User description

What he wants

- X
- X

User in action

- Xx
- Xx
- xx



Lorem ipsum dolor sit amet, consectetur adipiscing elit, sed do eiusmod tempor incididunt ut labore et dolore magna aliqua. Ut enim ad minim veniam, quis nostrud exercitation ullamco laboris nisi ut aliquip ex ea commodo consequat. Duis aute irure dolor in reprehenderit in voluptate velit esse cillum dolore eu fugiat nulla pariatur. Excepteur sint occaecat cupidatat non proident, sunt in culpa qui officia deserunt mollit anim id est laborum

Slide structure:
Headline on side

Point 1

- ▶ Subpoint
- ▶ Subpoint

Point 2

- ▶ Subpoint
- ▶ Subpoint

Slide structure: Simple charts

x

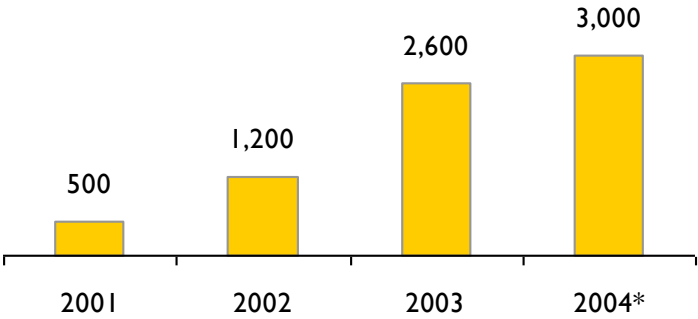

x

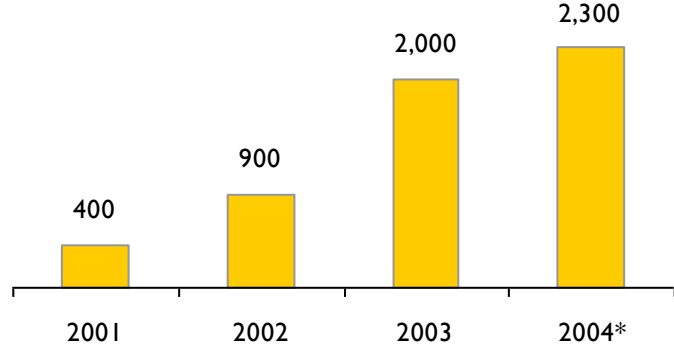

x

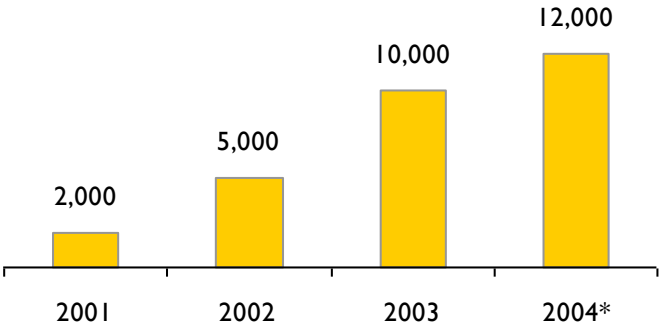

x

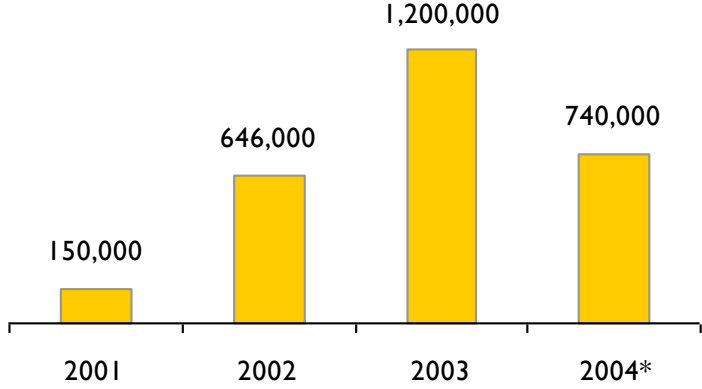

Slide structure: Business opportunity

MARKET OPPORTUNITY

- Lorem ipsum dolor sit amet, consectetur adipisicing elit, sed do eiusmod tempor incididunt ut labore et dolore magna aliqua. Ut enim ad minim veniam, quis nostrud exercitation ullamco laboris nisi ut aliquip ex ea commodo consequat. Duis aute irure dolor in reprehenderit in voluptate velit esse cillum dolore eu fugiat nulla pariatur. Excepteur sint occaecat cupidatat non proident, sunt in culpa qui officia deserunt mollit anim id est laborum



BUSINESS CONCEPT

- Lorem ipsum dolor sit amet, consectetur adipisicing elit, sed do eiusmod tempor incididunt ut labore et dolore magna aliqua.
 - Ut enim ad minim veniam, quis nostrud exercitation ullamco laboris nisi ut aliquip ex ea commodo consequat.
 - Duis aute irure dolor in reprehenderit in voluptate velit esse cillum dolore eu fugiat nulla pariatur.

KEY SUCCESS FACTORS

	Existing Asset	Approach
x	✓	• x
x	✓	• x
x	✓	• x
x	✓	• x

