

CONFIDENTIAL

Frequently Used Template

2X2 CUBED

Unit of measure

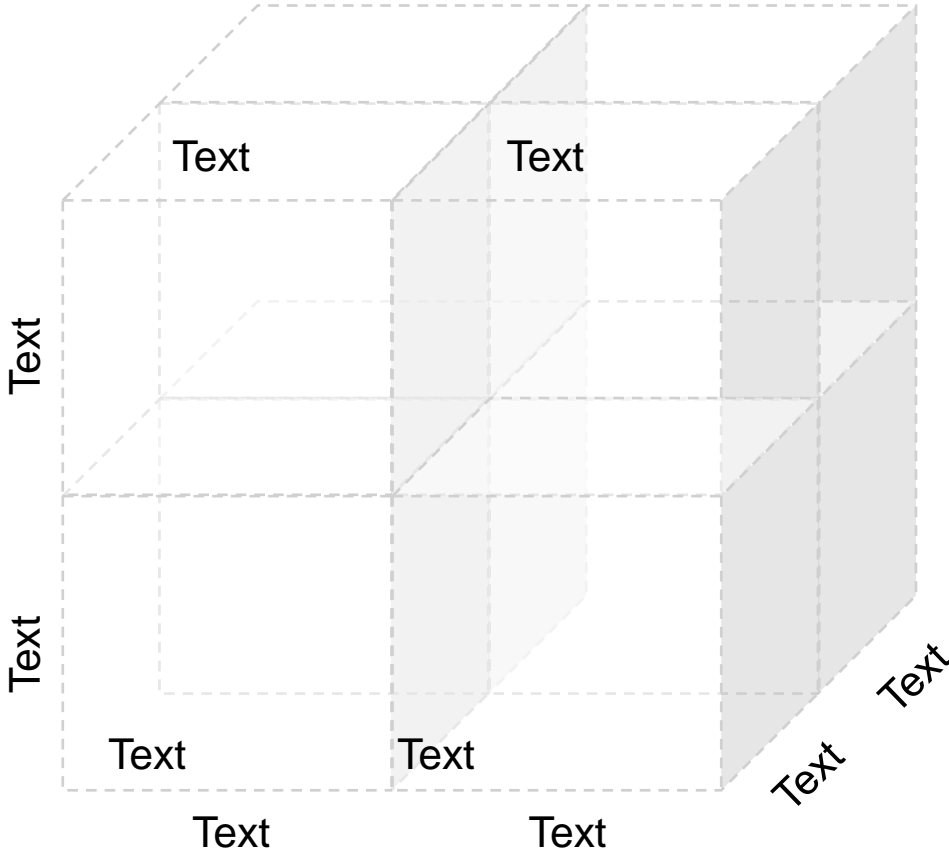

* Footnote

2X2 TOWER

Unit of measure

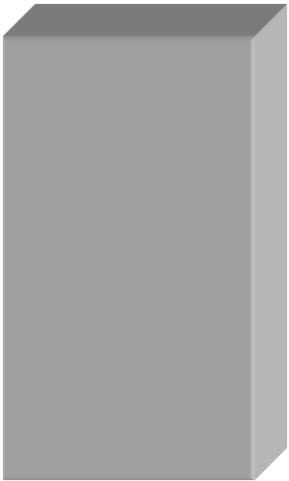
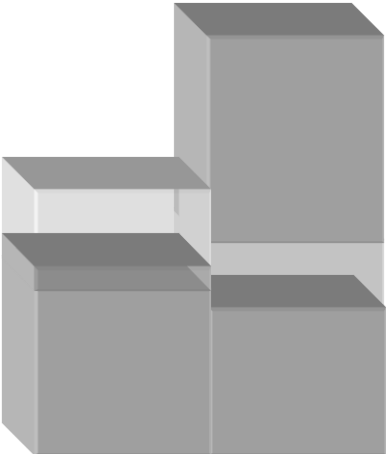

* Footnote

5PS MARKETING

Unit of measure

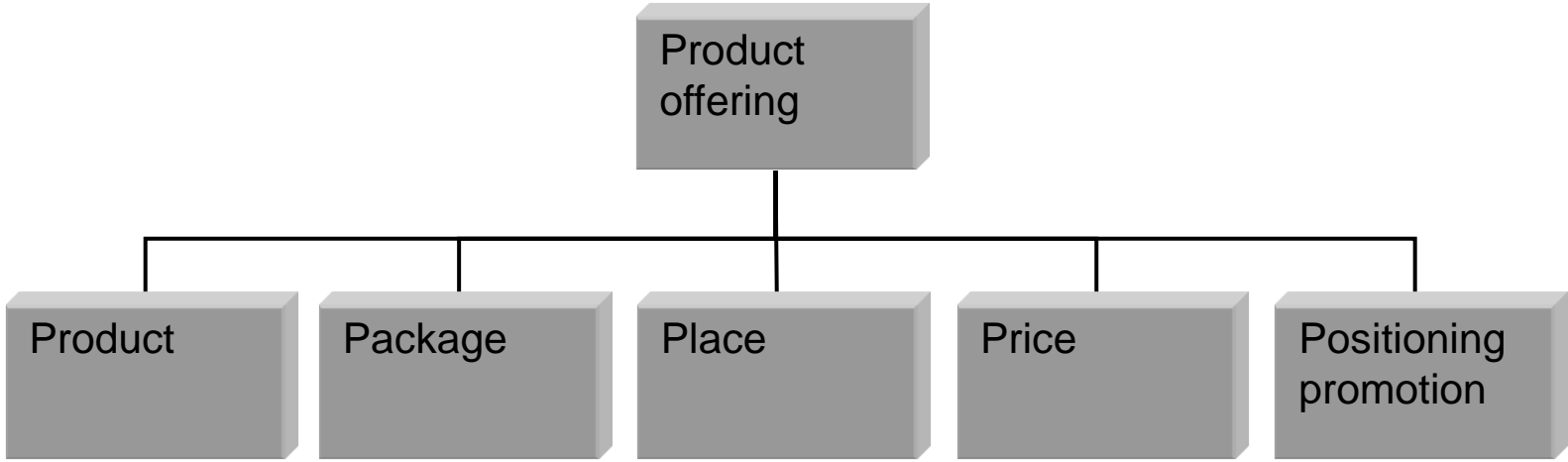

* Footnote

7S

Unit of measure

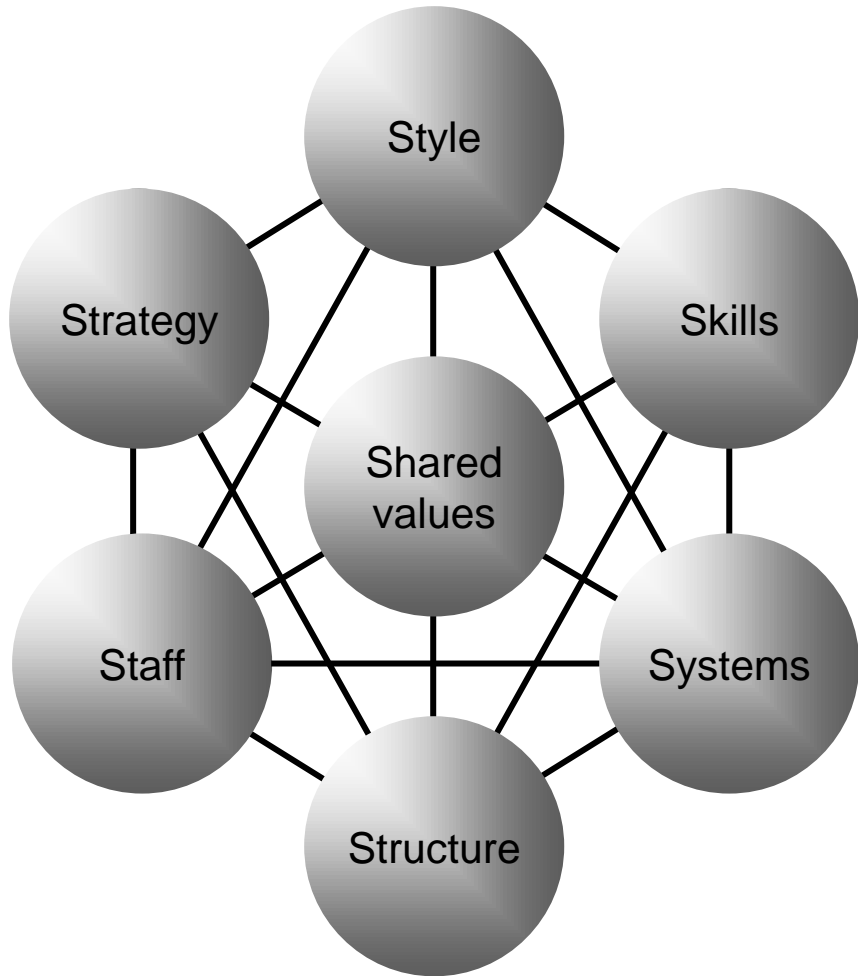

* Footnote

ARROW 3D

Unit of measure

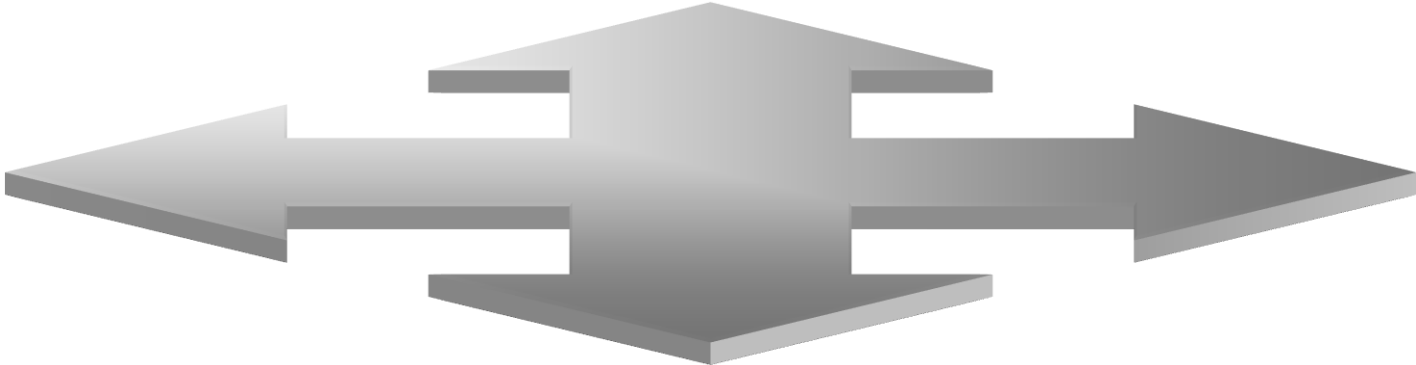

* Footnote

CUBES1 3D

Unit of measure

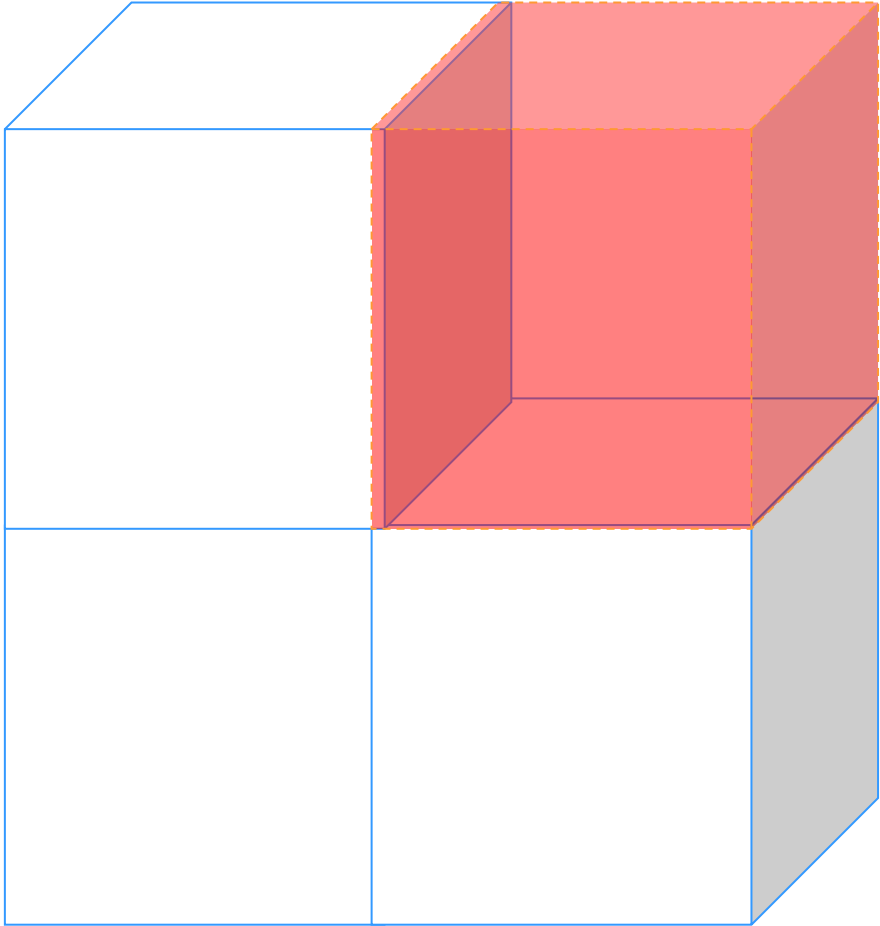
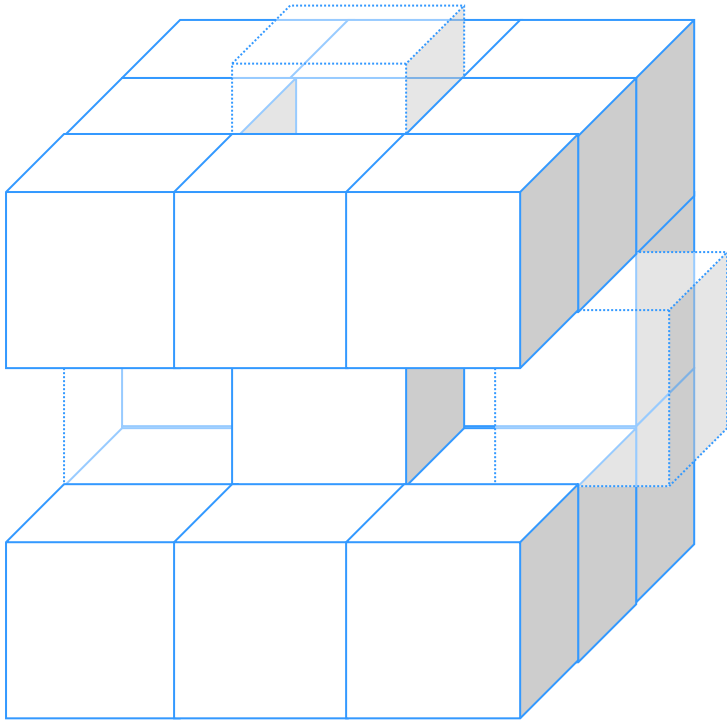

* Footnote

CUBES2 3D

Unit of measure

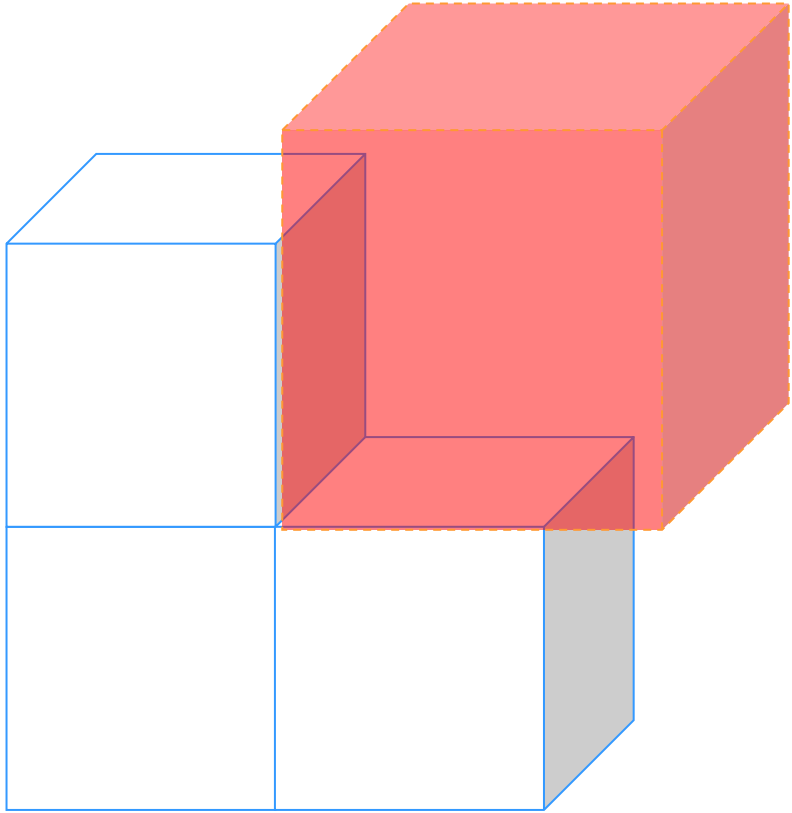
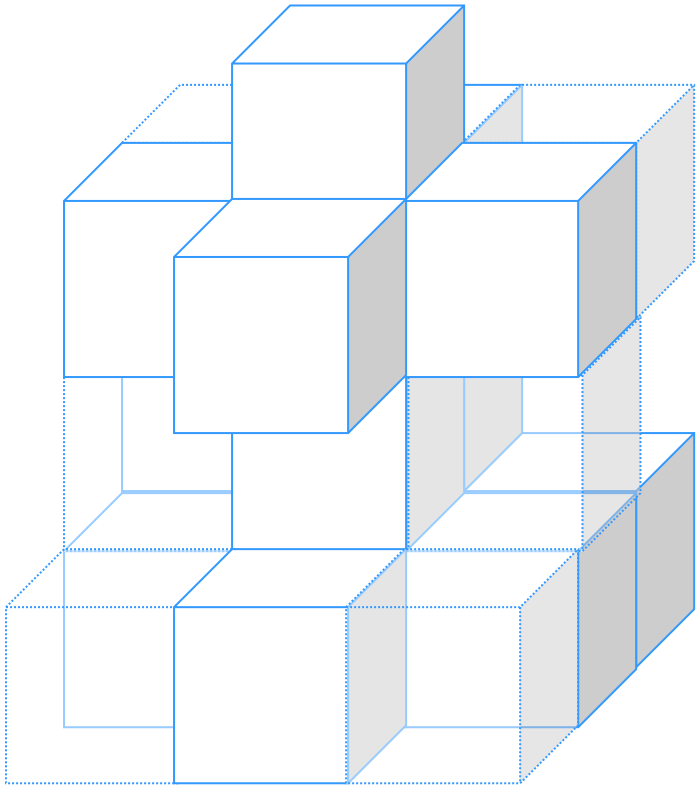

* Footnote

CUBES3 3D

Unit of measure

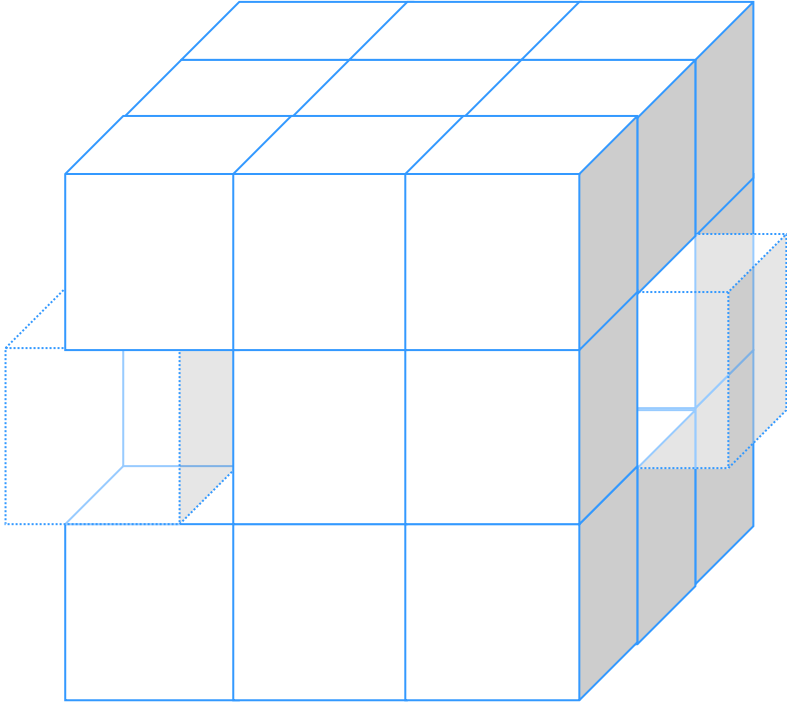
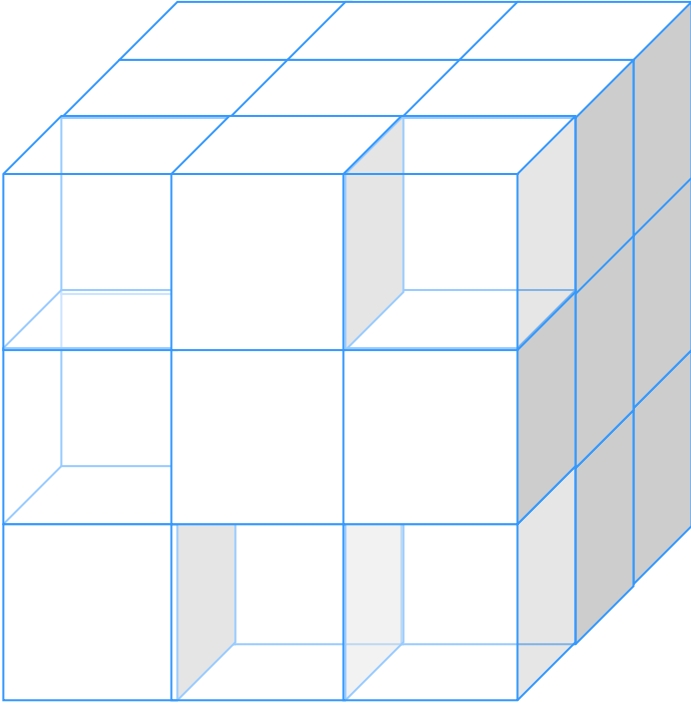

* Footnote

CUTOUT 3D

Unit of measure

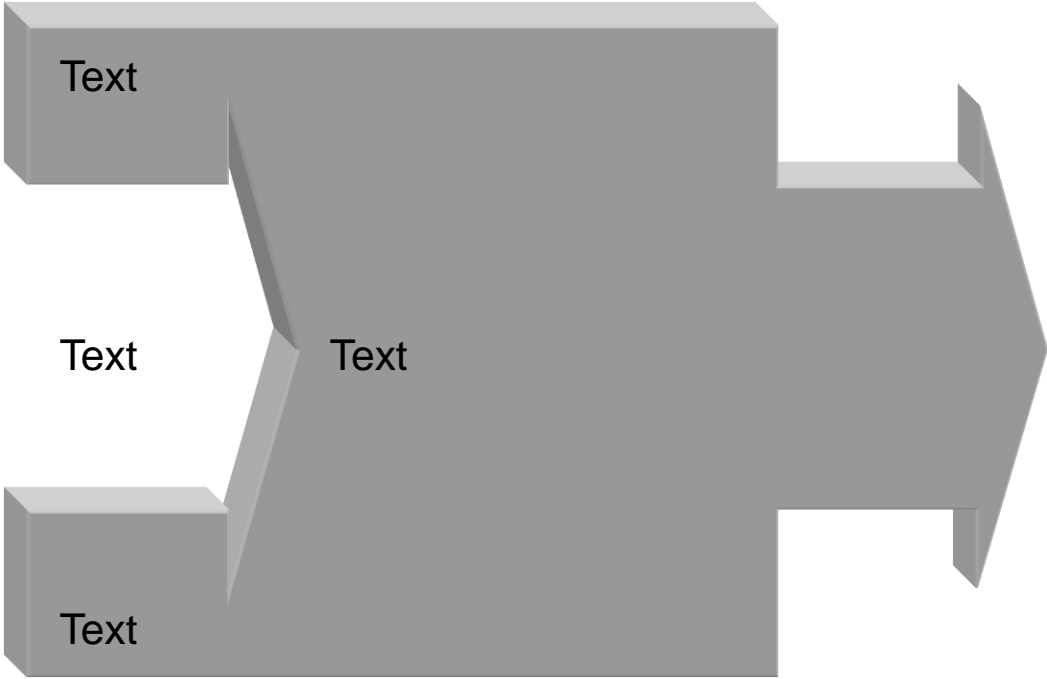

* Footnote

FORCES AT WORK

Unit of measure

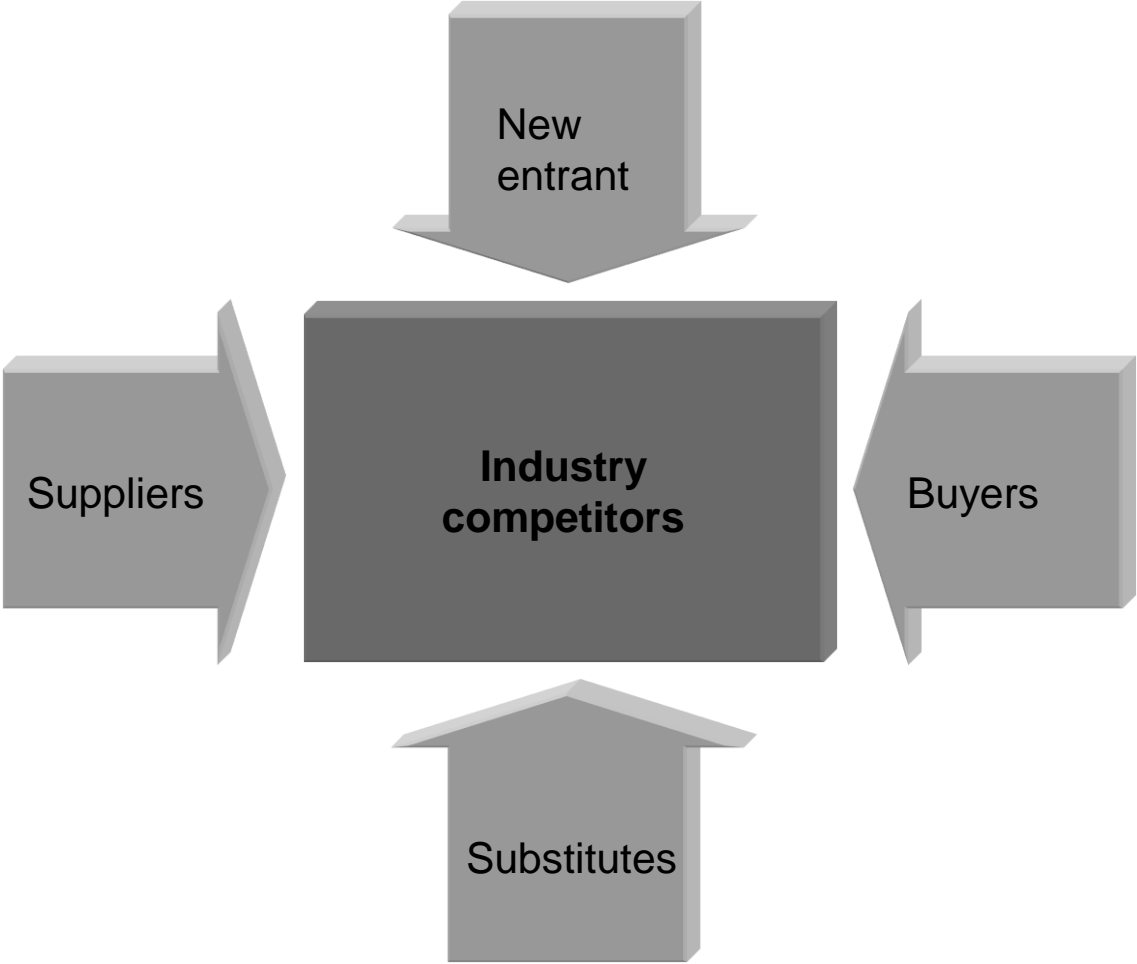

* Footnote

JOINT

Unit of measure

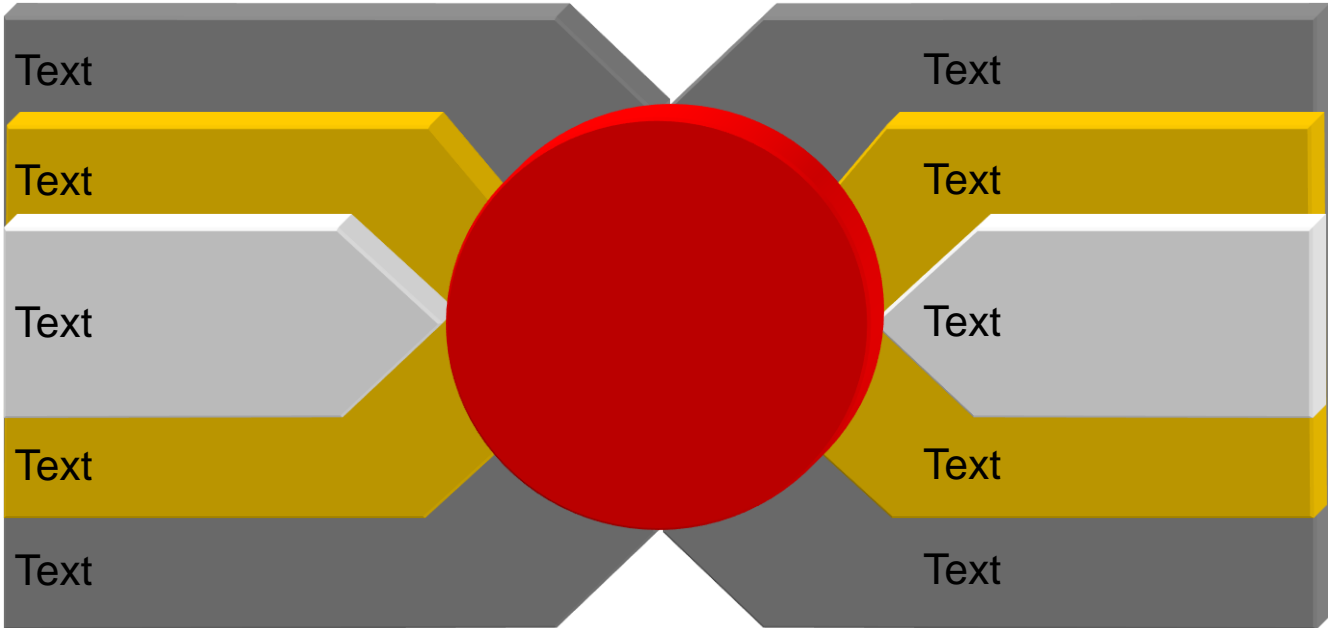

* Footnote
Source: Source

LEVEL SEPARATE 4

Unit of measure

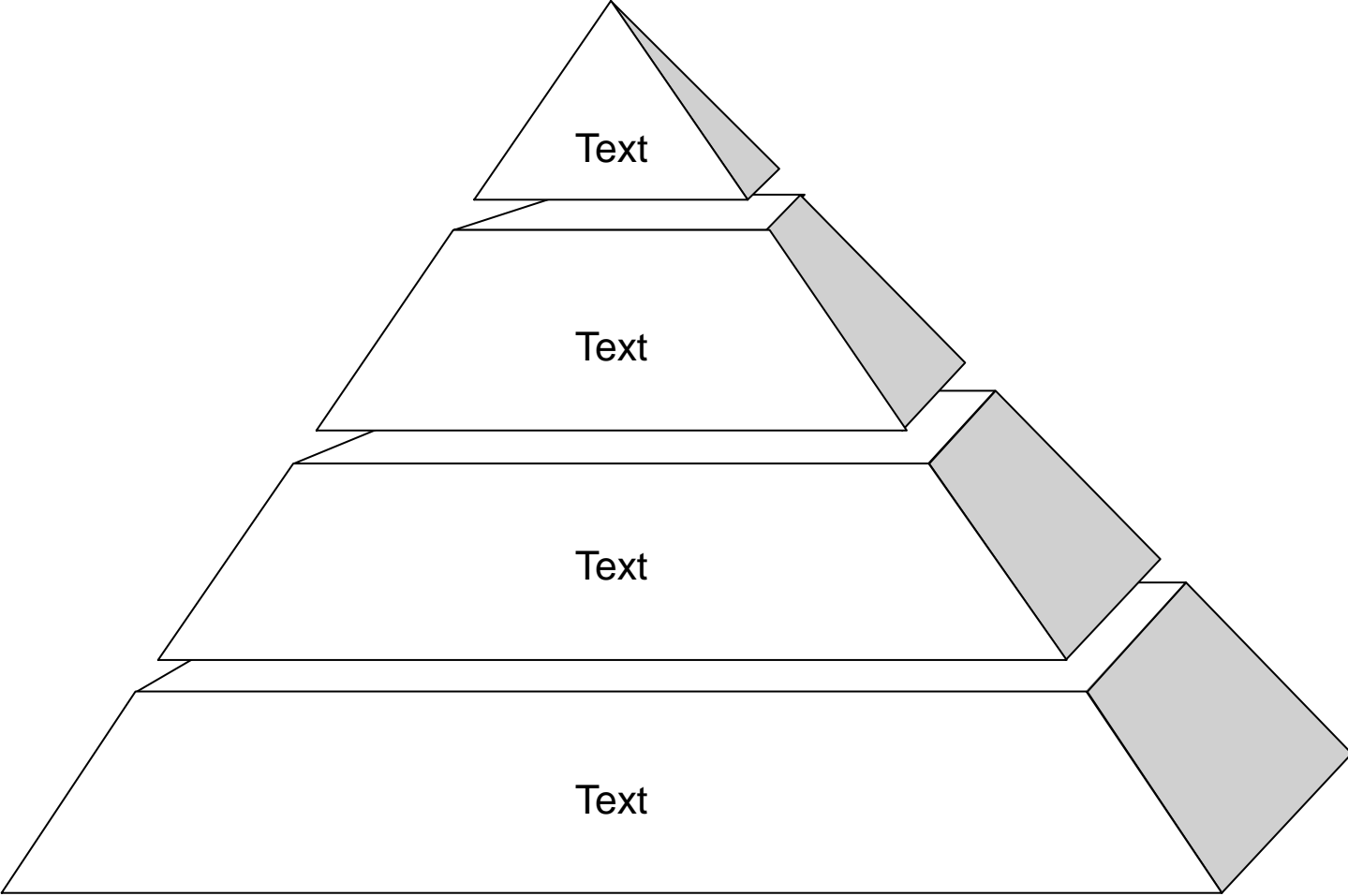

* Footnote

LINEAR A 3D

Unit of measure

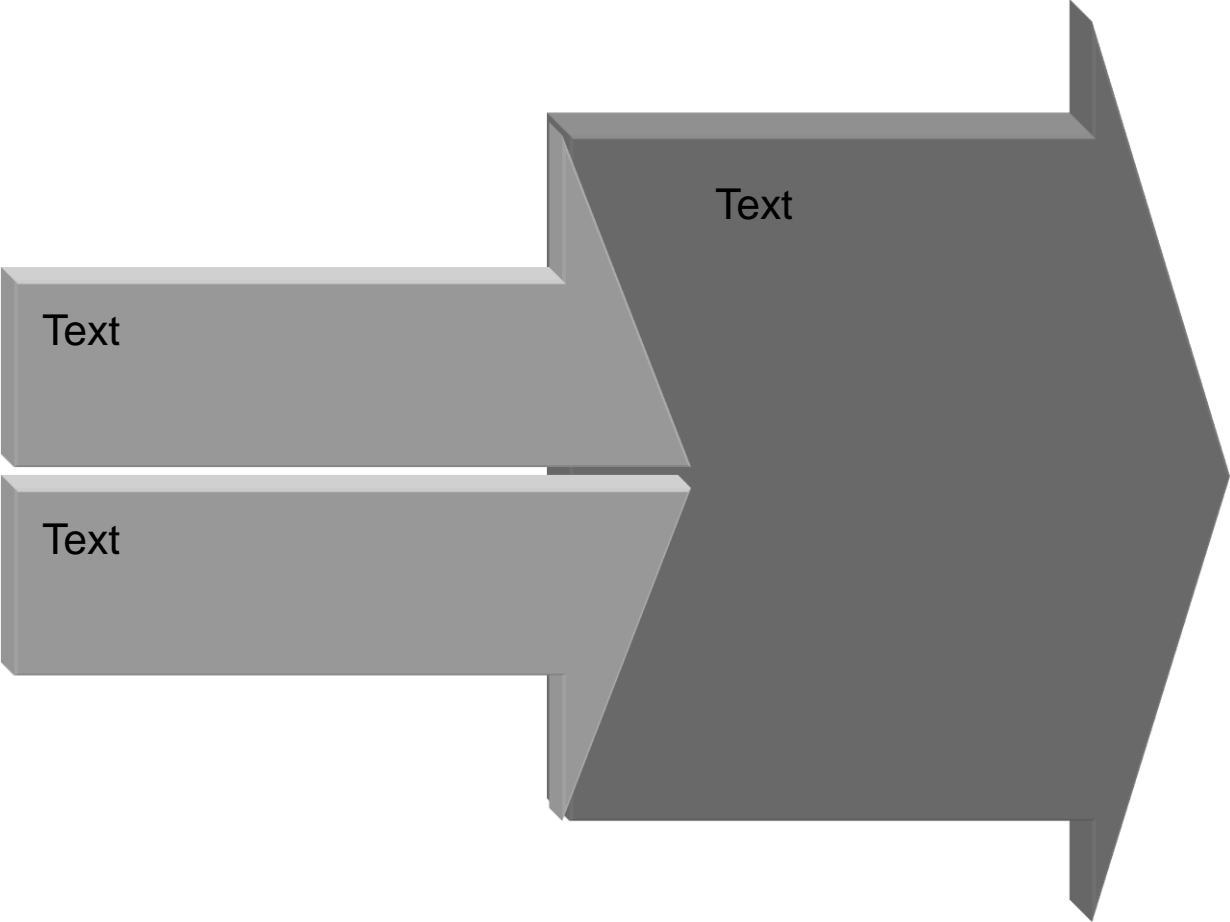

* Footnote

LINEAR B 3D

Unit of measure

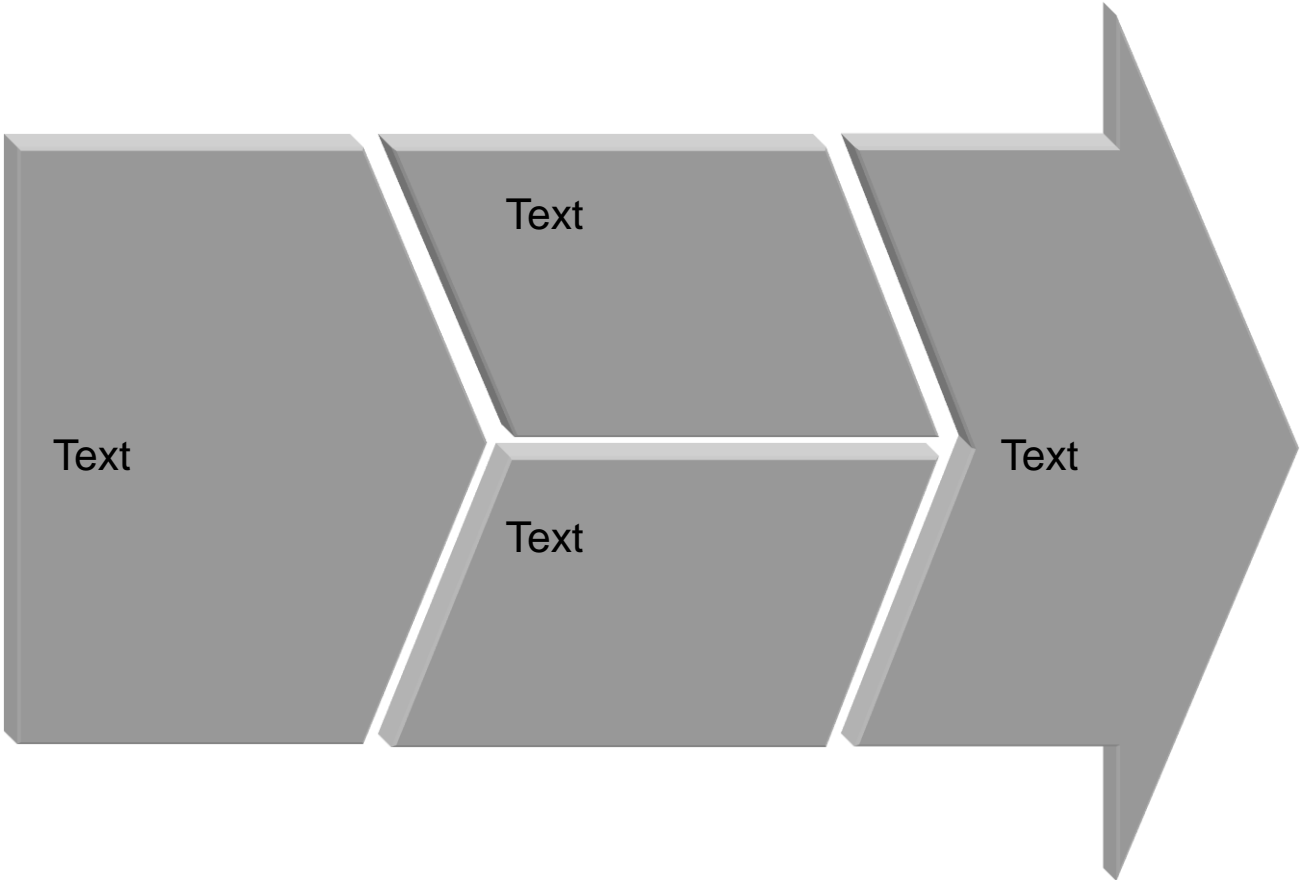

* Footnote

LINEAR C 3D

Unit of measure



* Footnote

LINEAR D 3D

Unit of measure

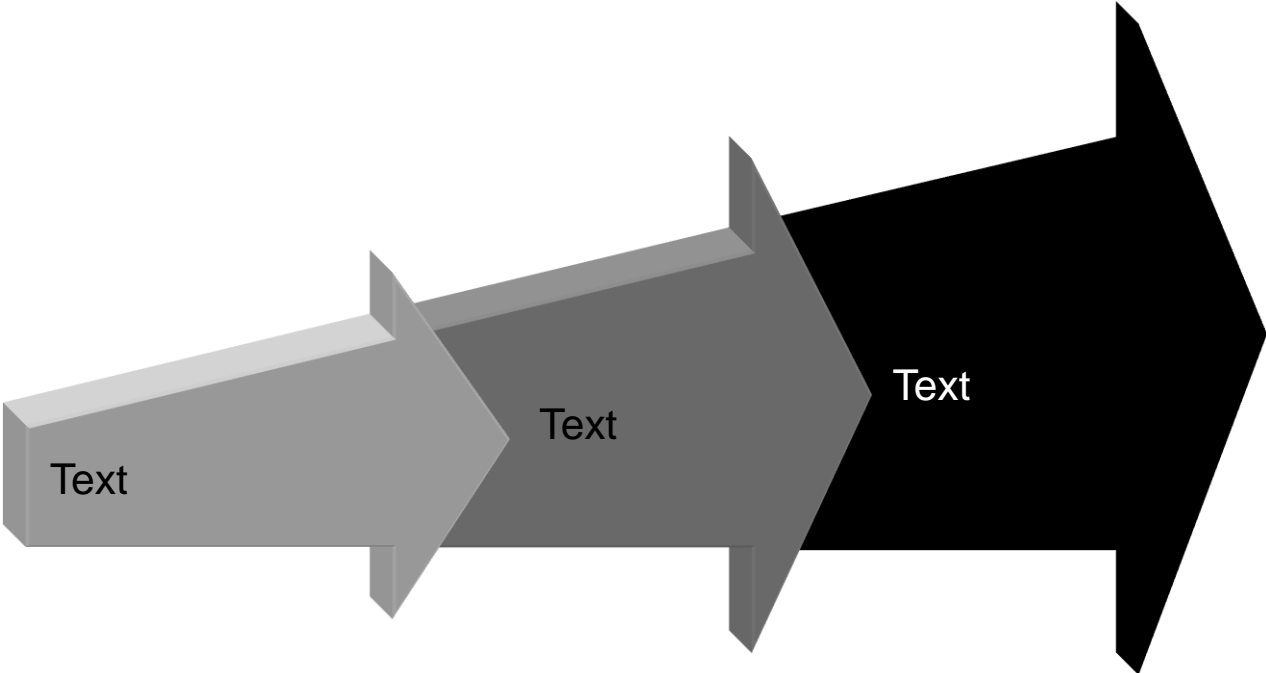

* Footnote

LINEAR E 3D

Unit of measure

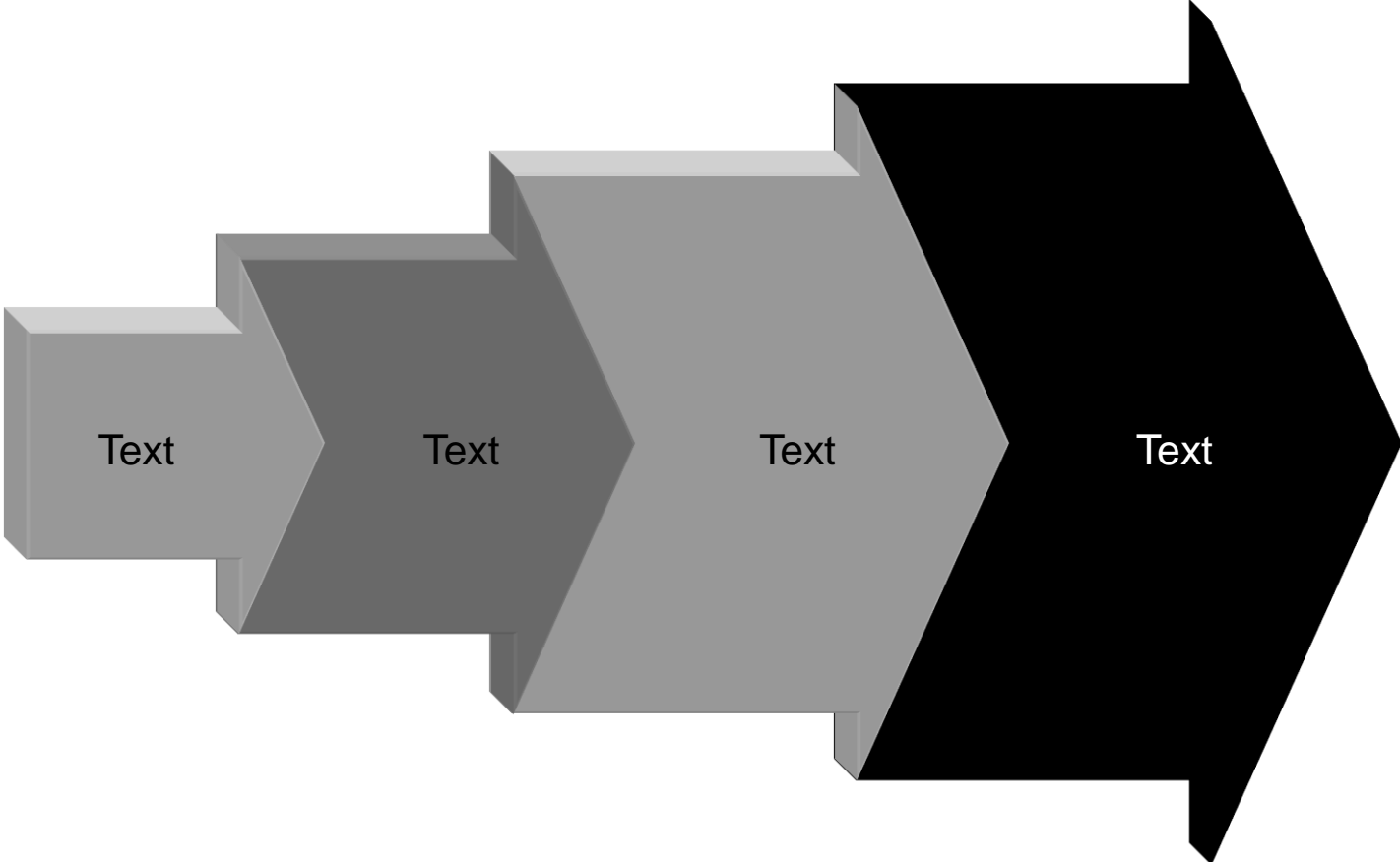

* Footnote

LINEAR G 3D

Unit of measure

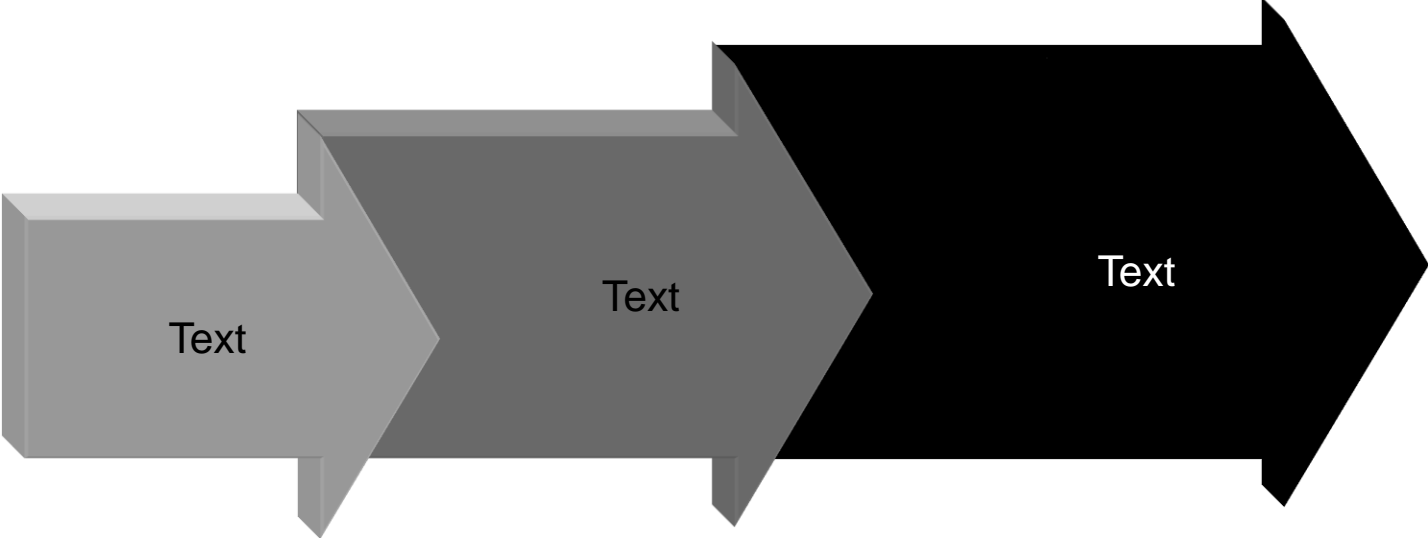

* Footnote

LINEAR | 3D

Unit of measure

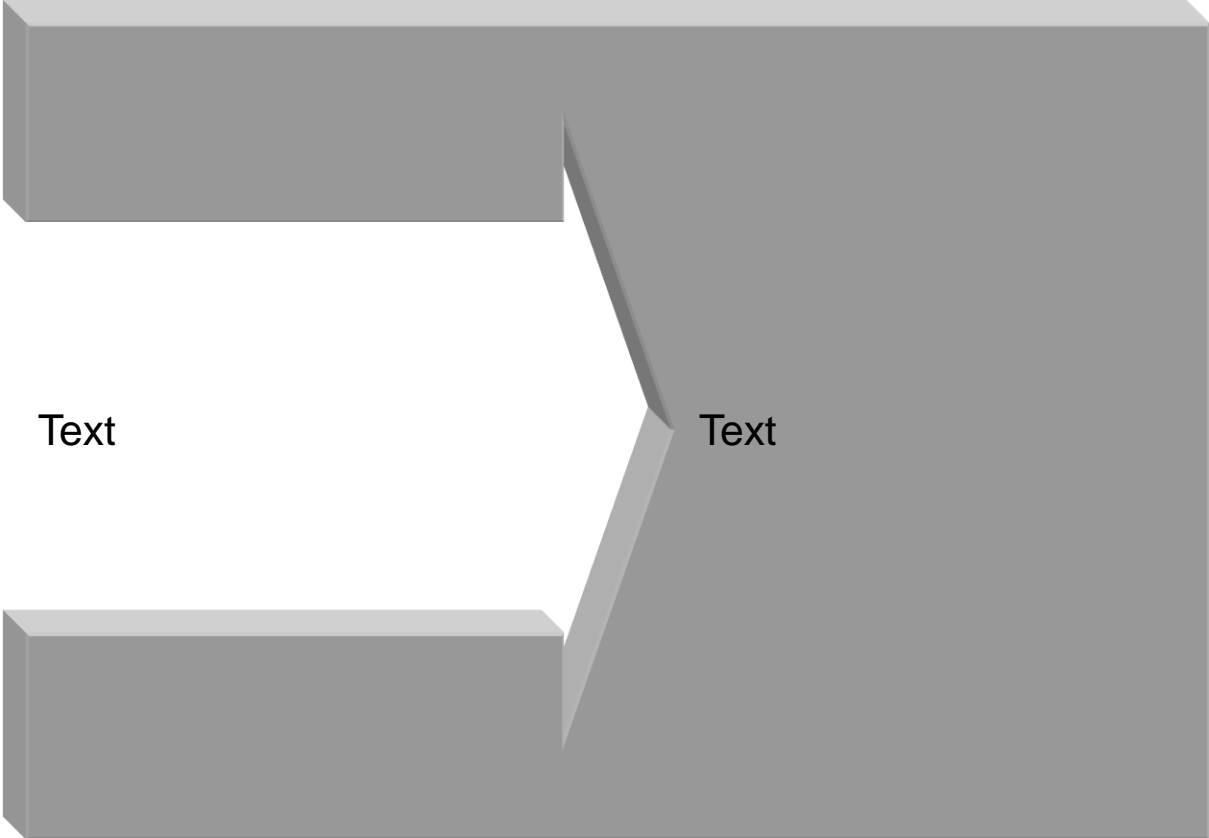

* Footnote

LINEAR J 3D

Unit of measure

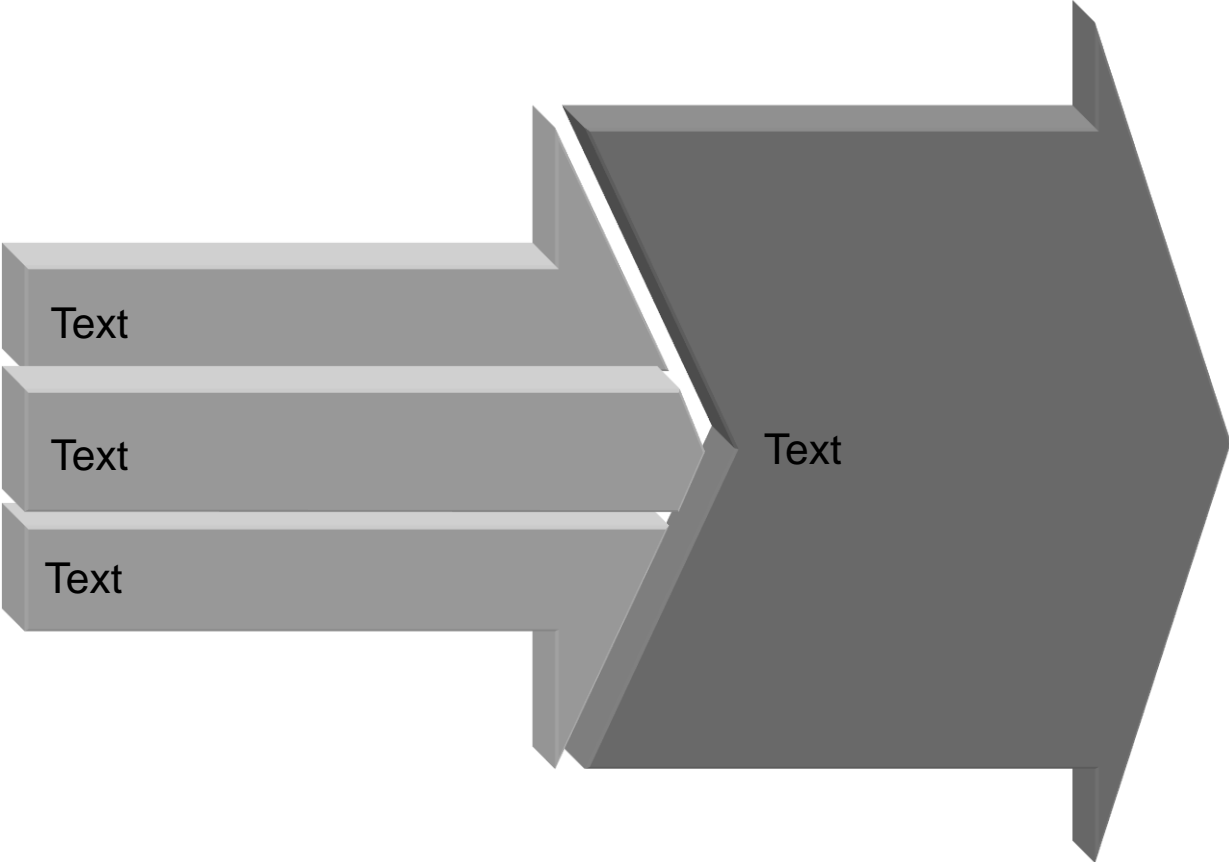

* Footnote

LINEAR N 3D

Unit of measure

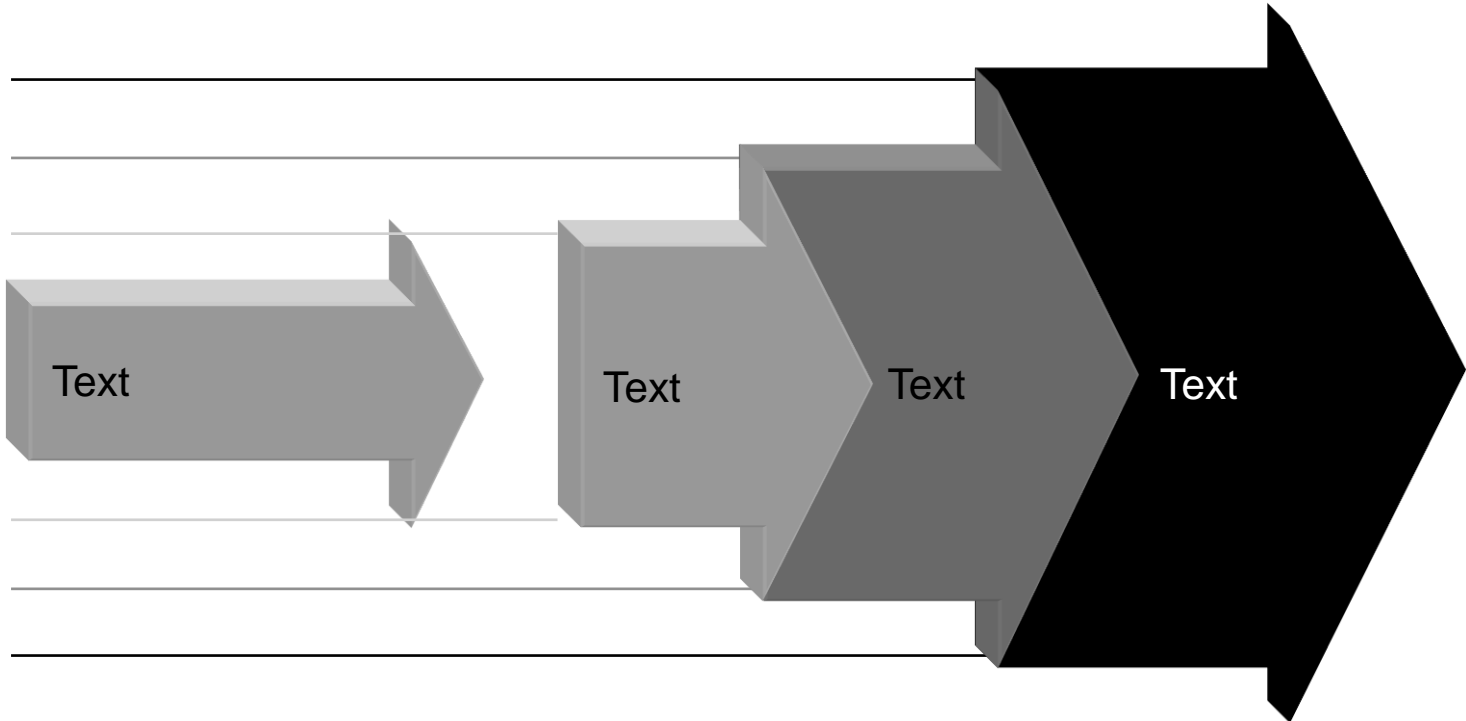

* Footnote

LINEAR P 3D

Unit of measure

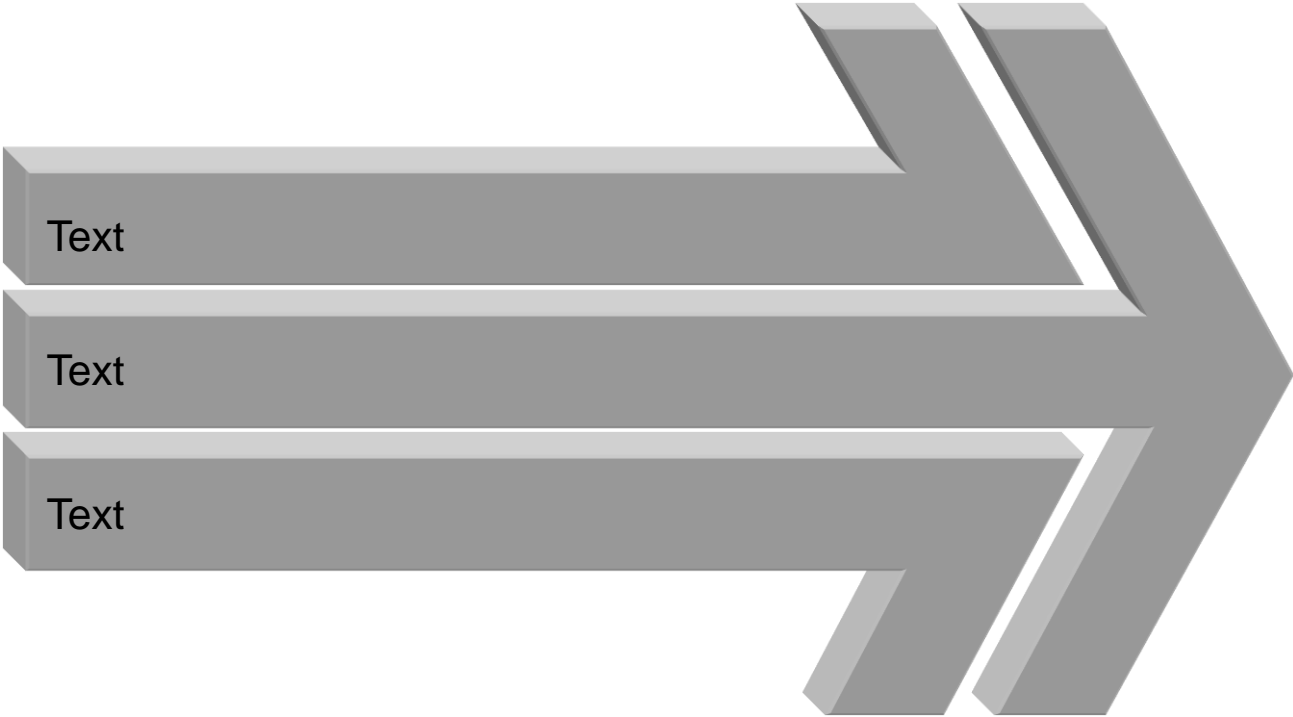

* Footnote

LINEAR Q 3D

Unit of measure

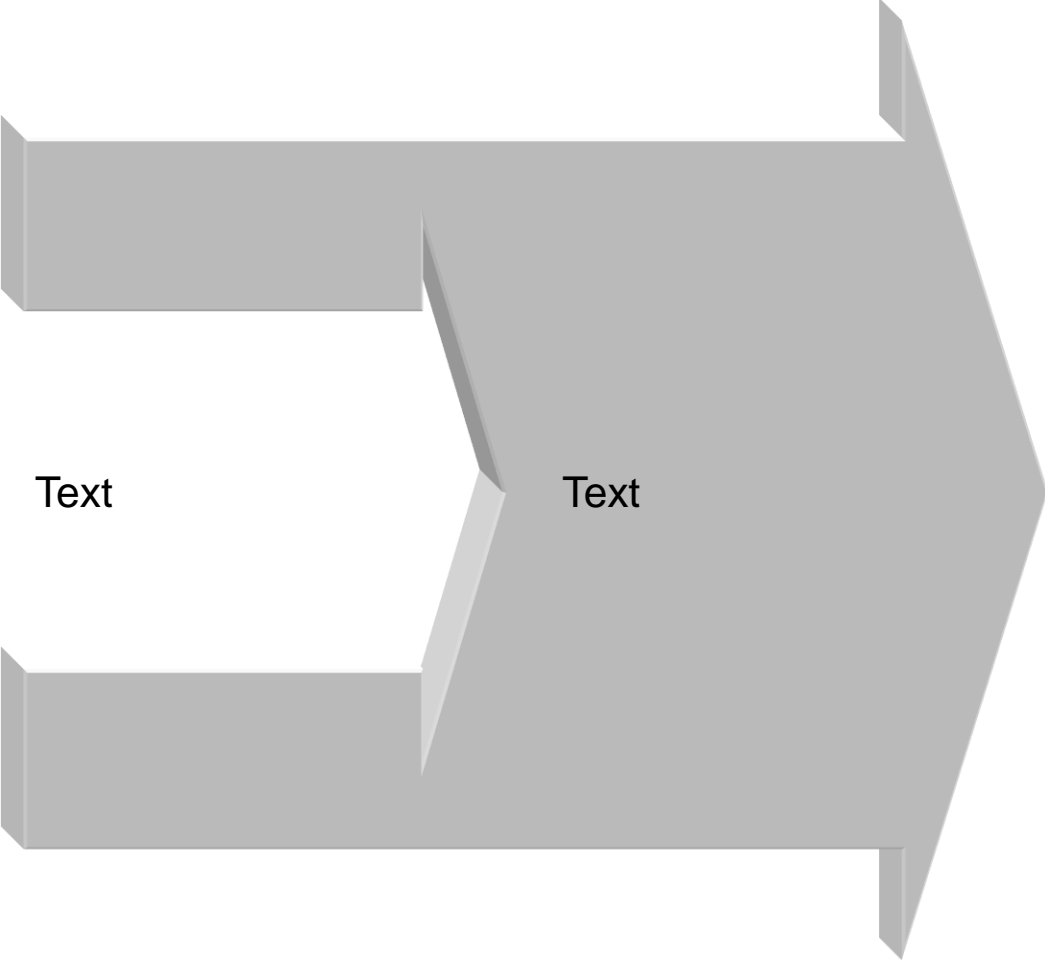

* Footnote

LINEAR Q 3D

Unit of measure

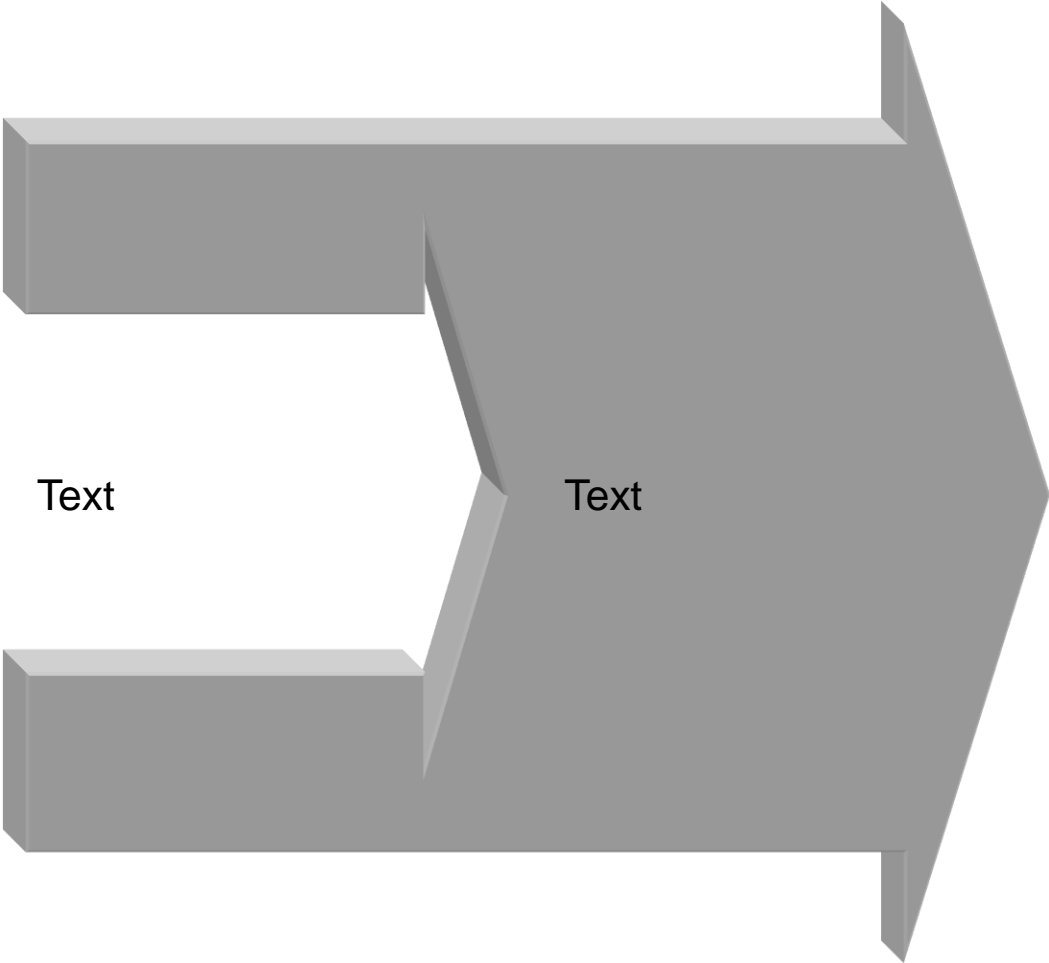

Text

Text

* Footnote

LINKS 3

Unit of measure

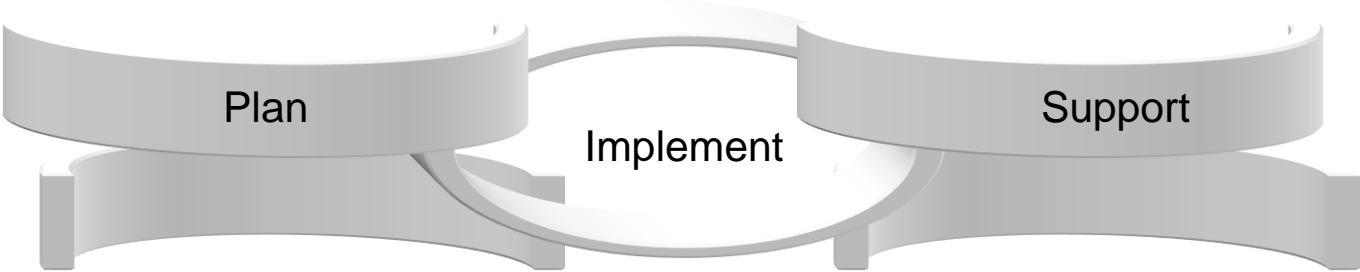

* Footnote

PERSPECTIVE 3D

Unit of measure

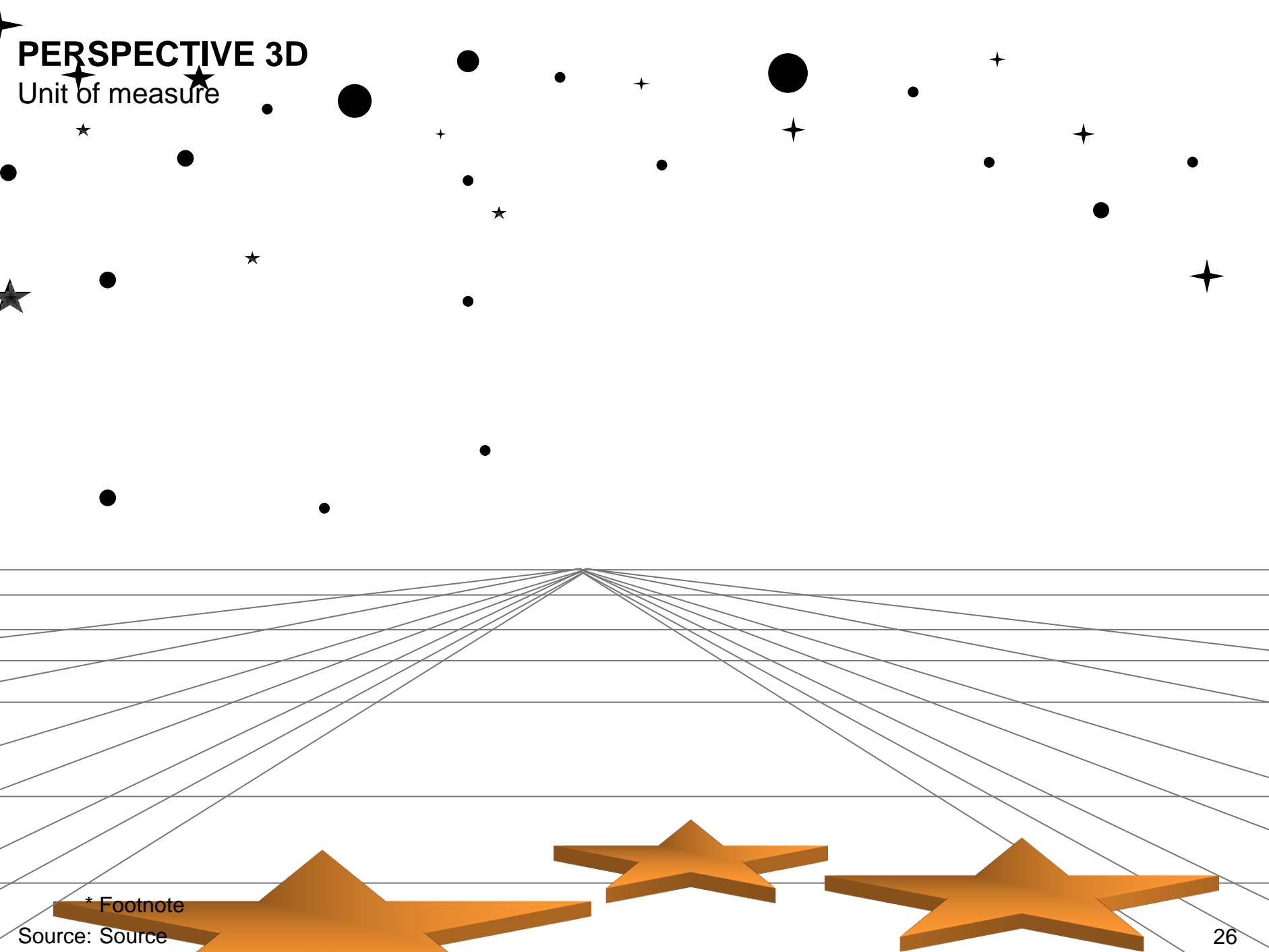

* Footnote

Source: Source

PROPELLER 3D

Unit of measure

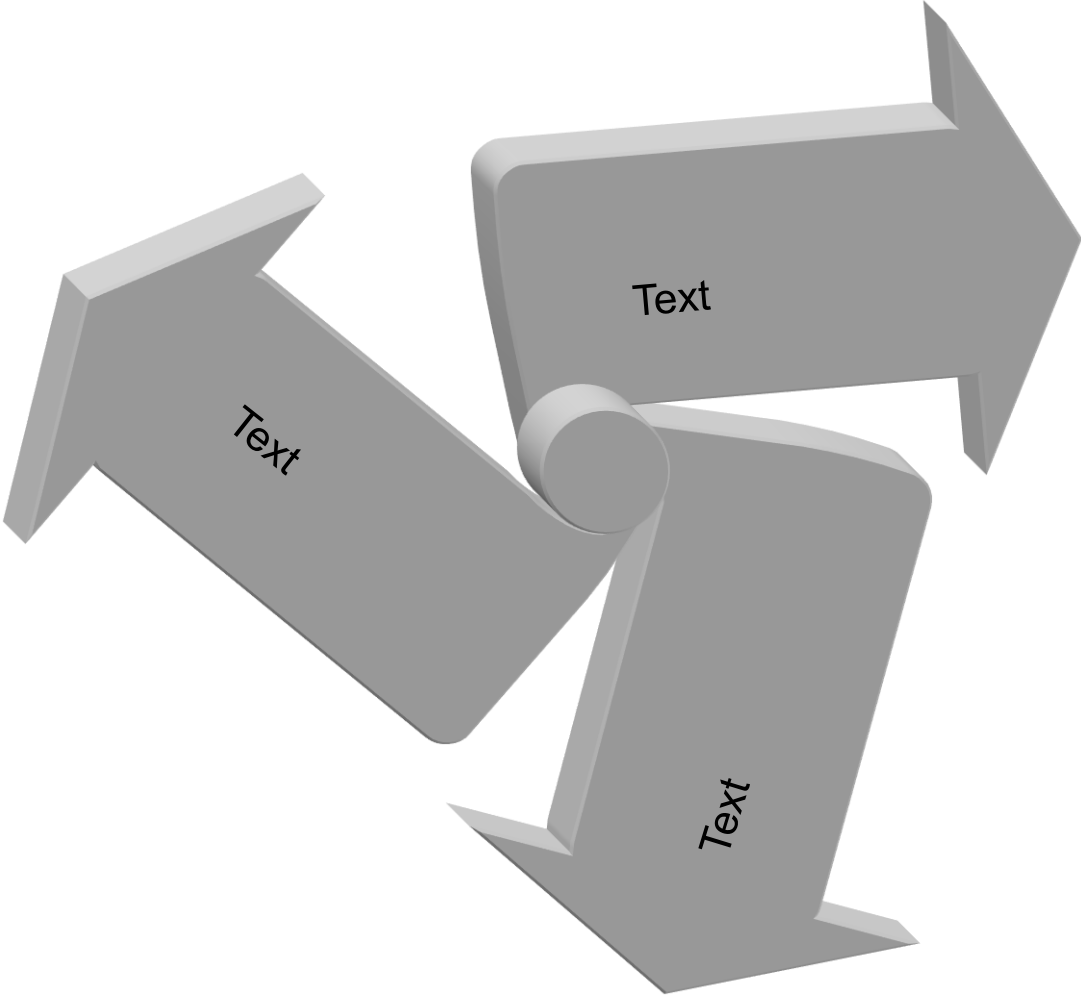

* Footnote

RINGS 3D

Unit of measure

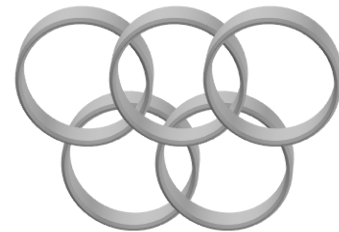
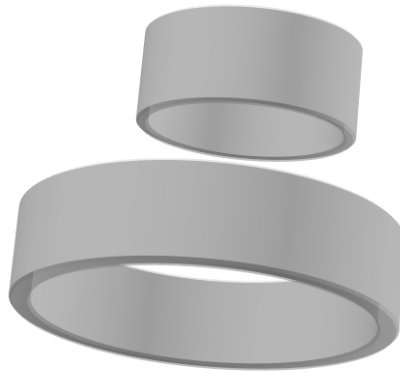

* Footnote

SCALE

Unit of measure

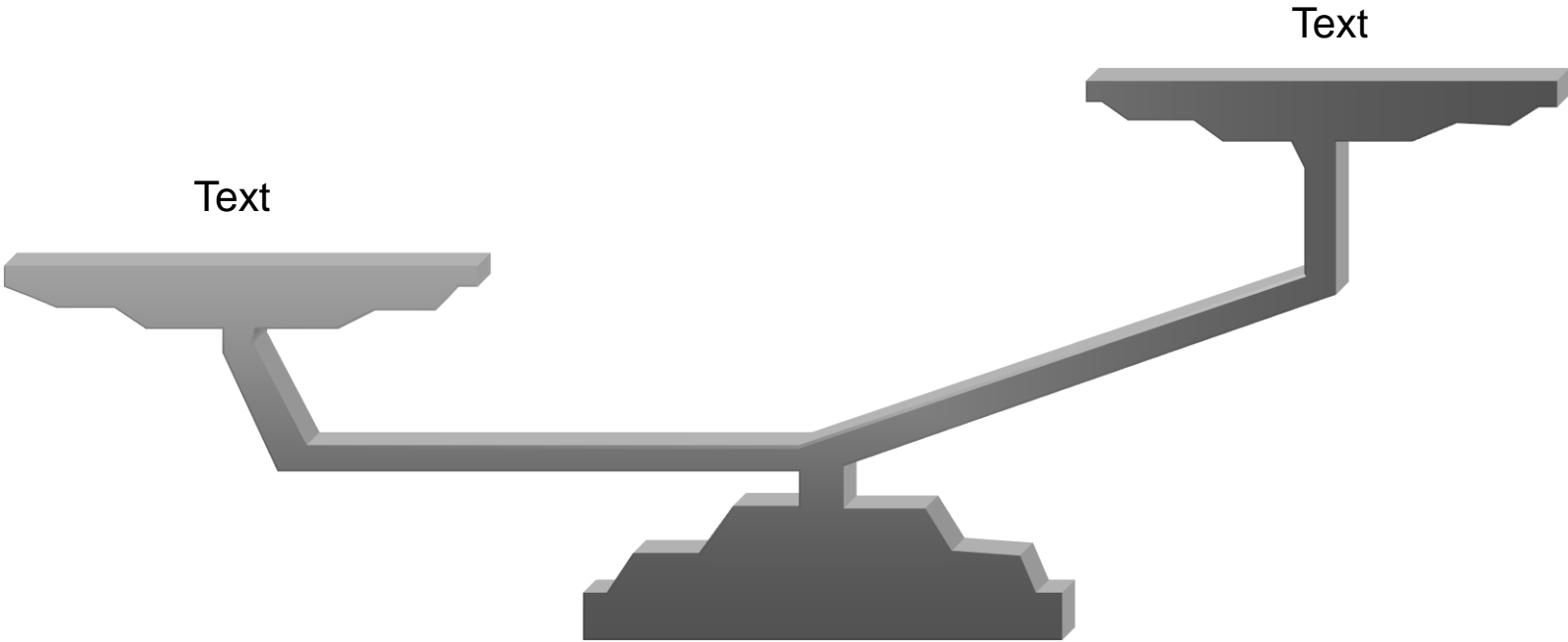

* Footnote

SCALES

Unit of measure

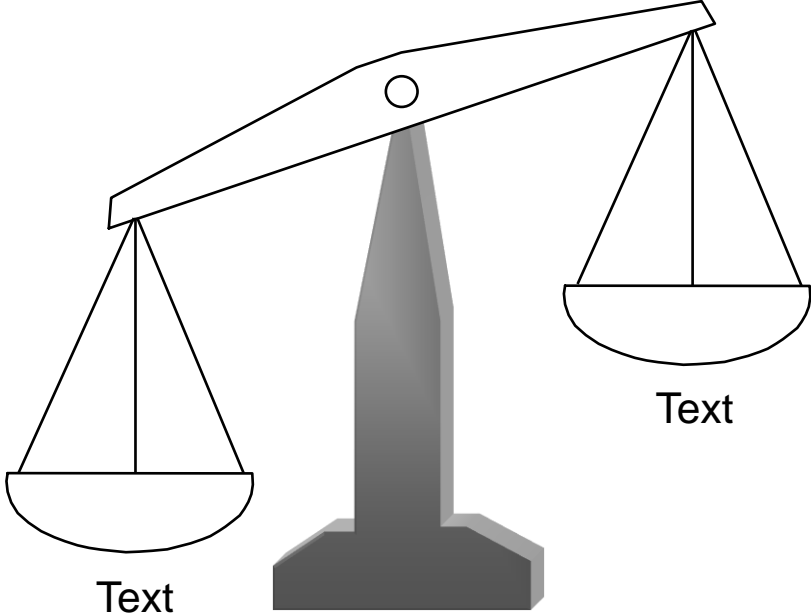

* Footnote

SIZES IN
Unit of measure

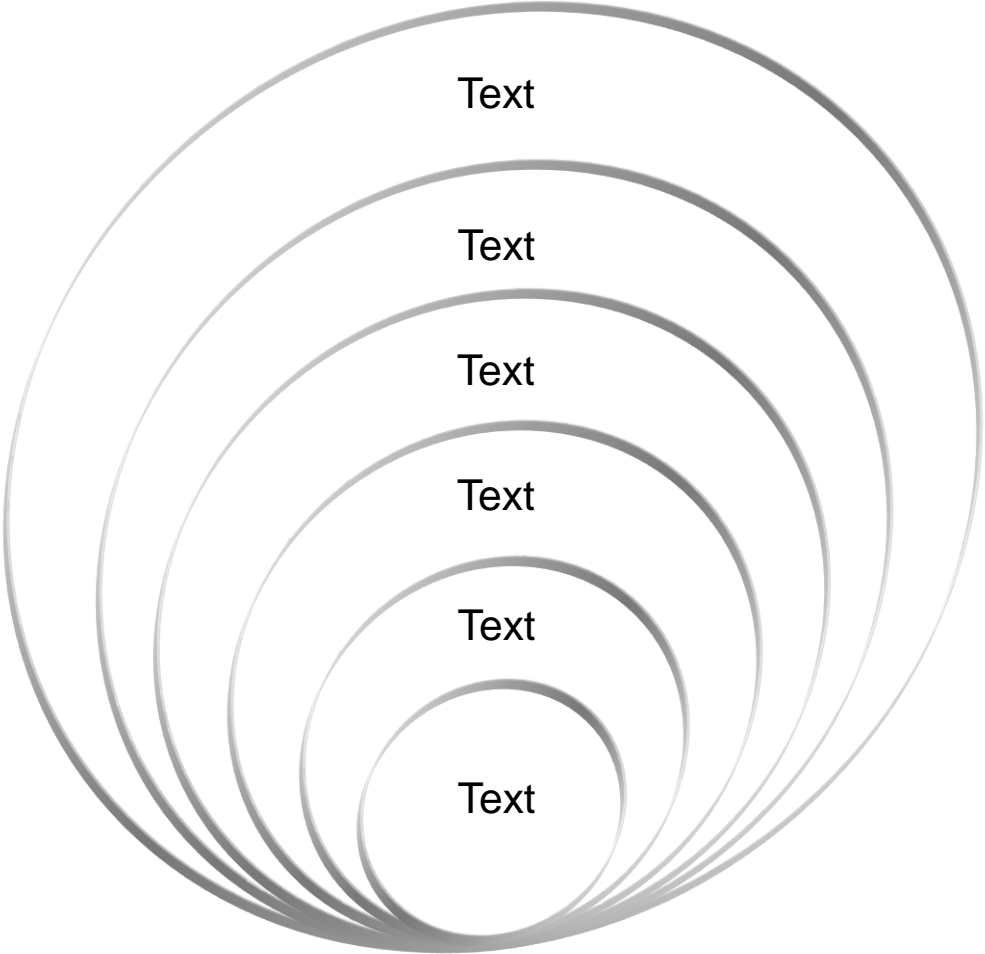

* Footnote

SPIRAL1 3D

Unit of measure

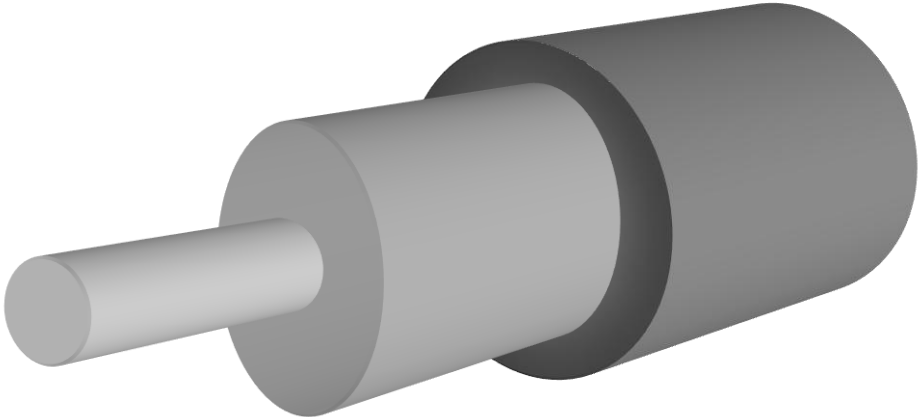
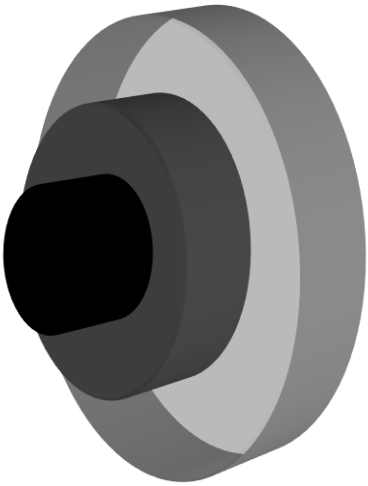
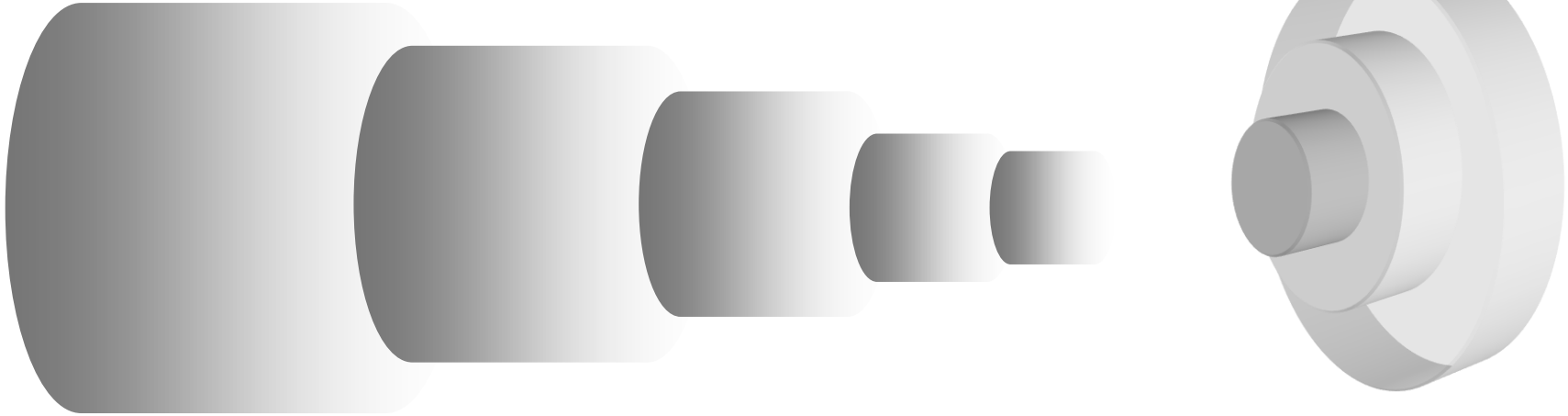

* Footnote

SPIRAL2 3D
Unit of measure

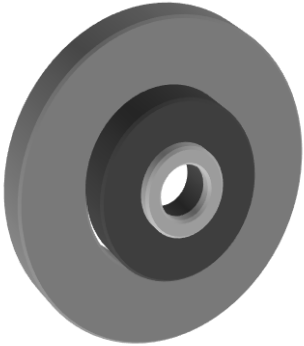
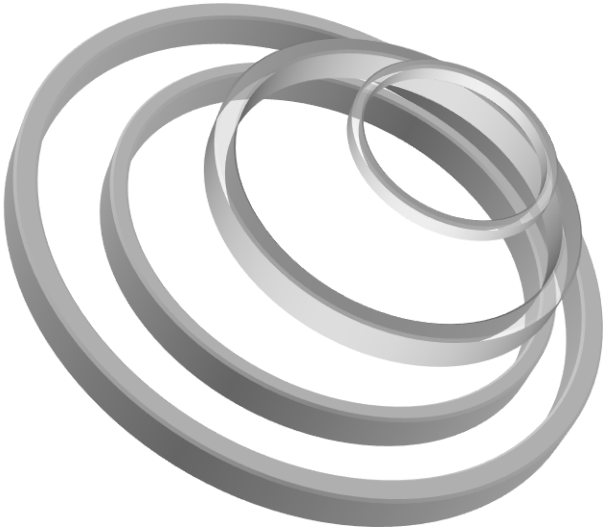

Brakes

Spiral

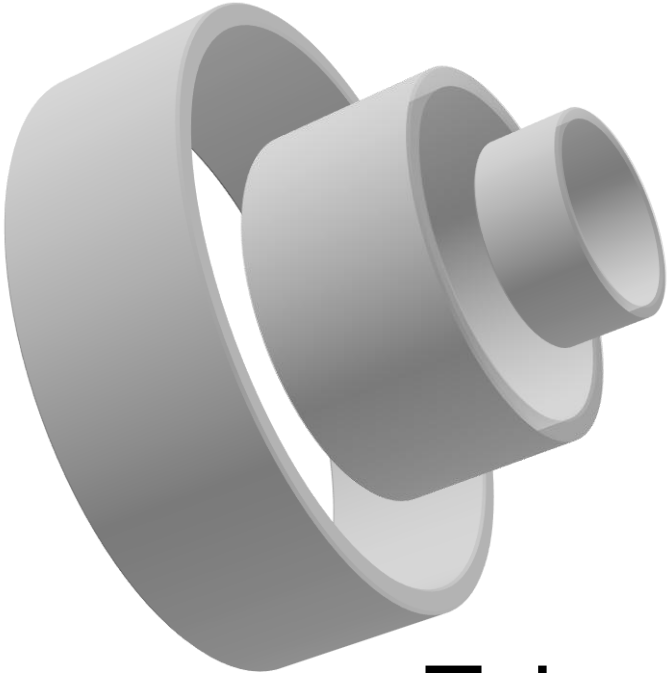

Tube in tube



* Footnote
Source: Source

SPOTLIGHT

Unit of measure

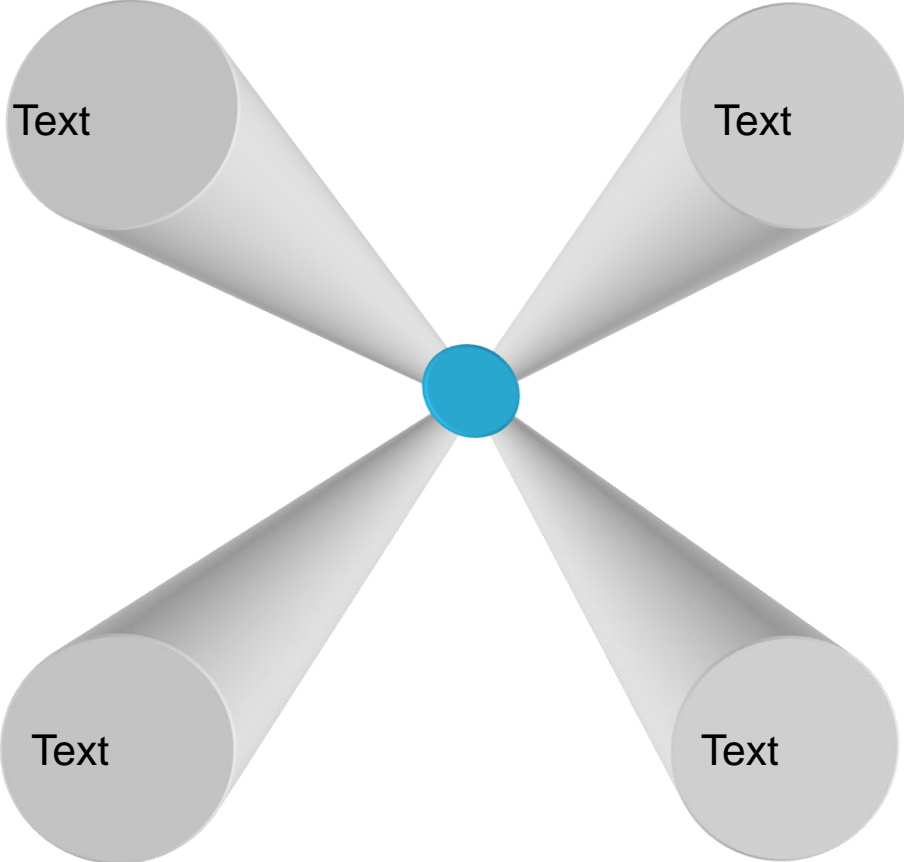

* Footnote

STAIRCASE

Unit of measure

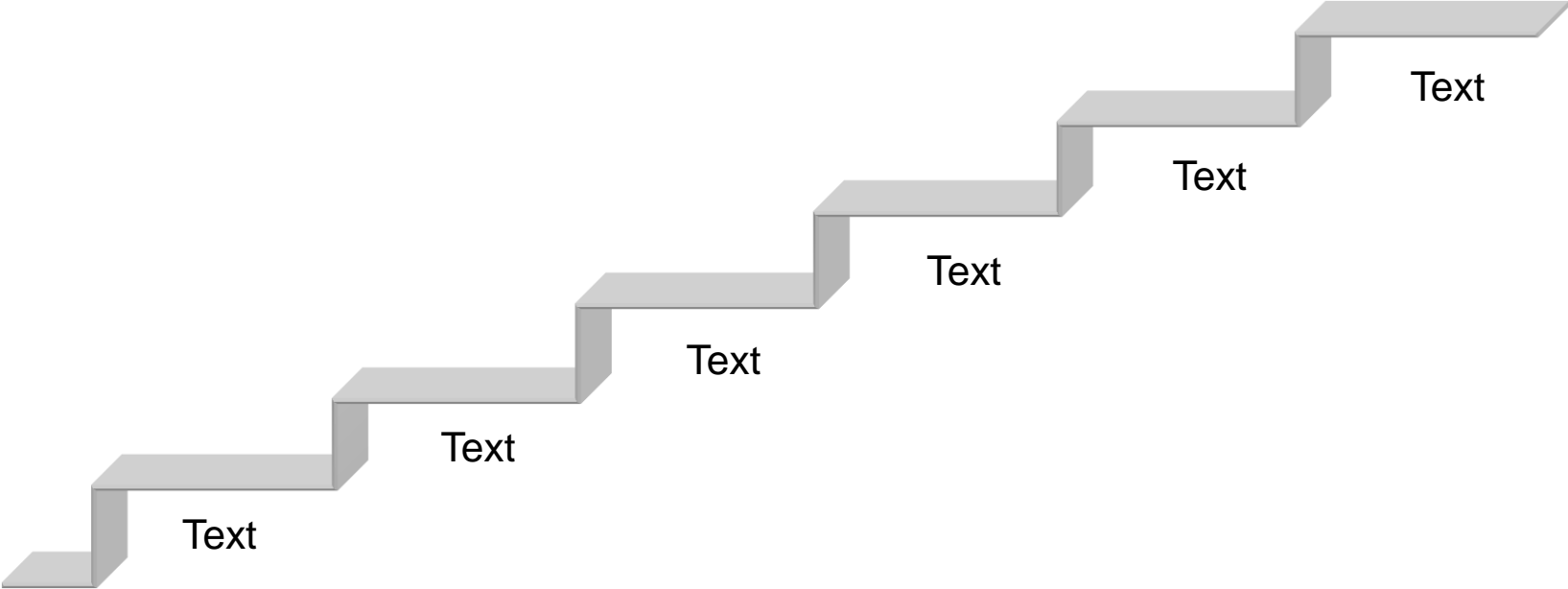

* Footnote

STARS 3D

Unit of measure

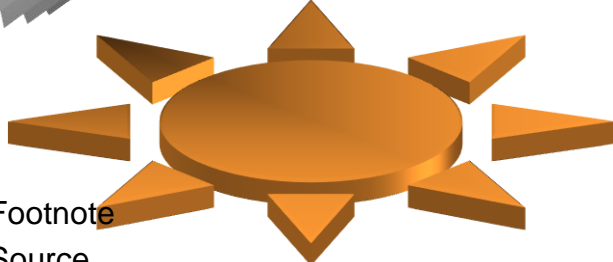
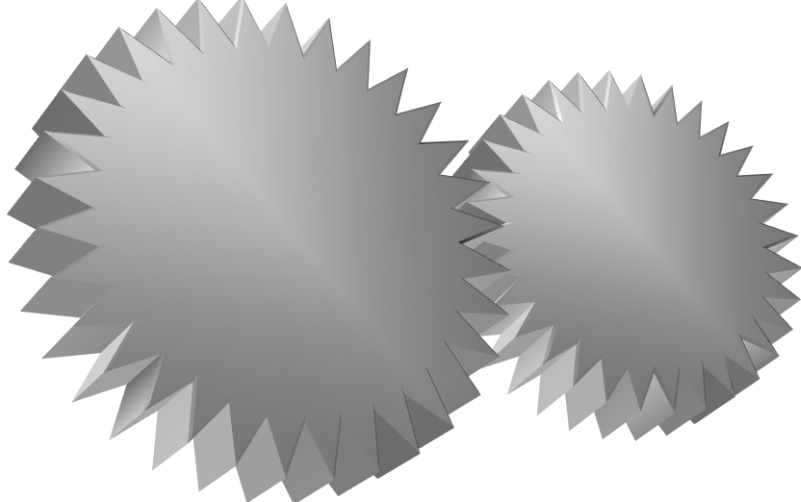
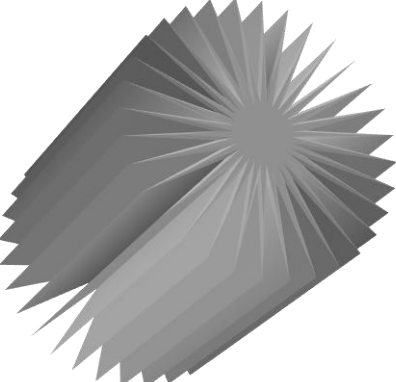
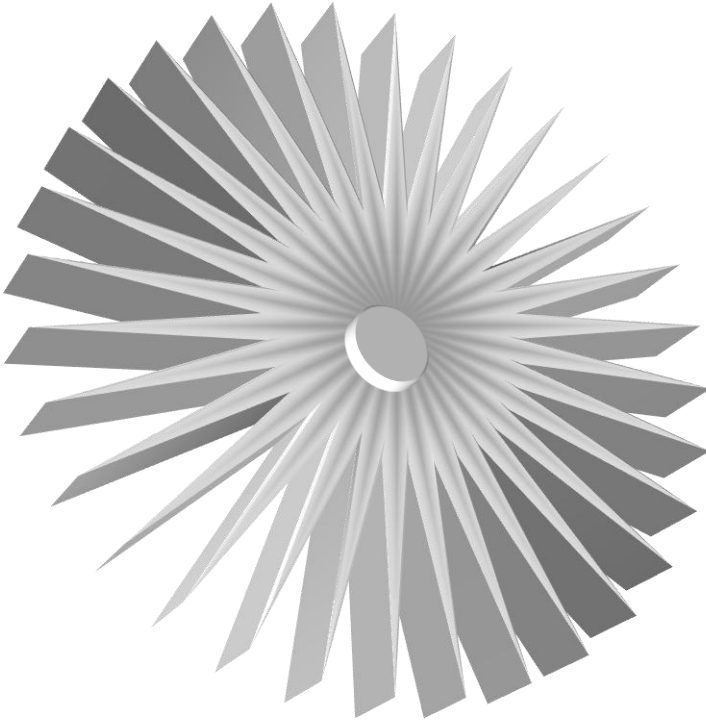
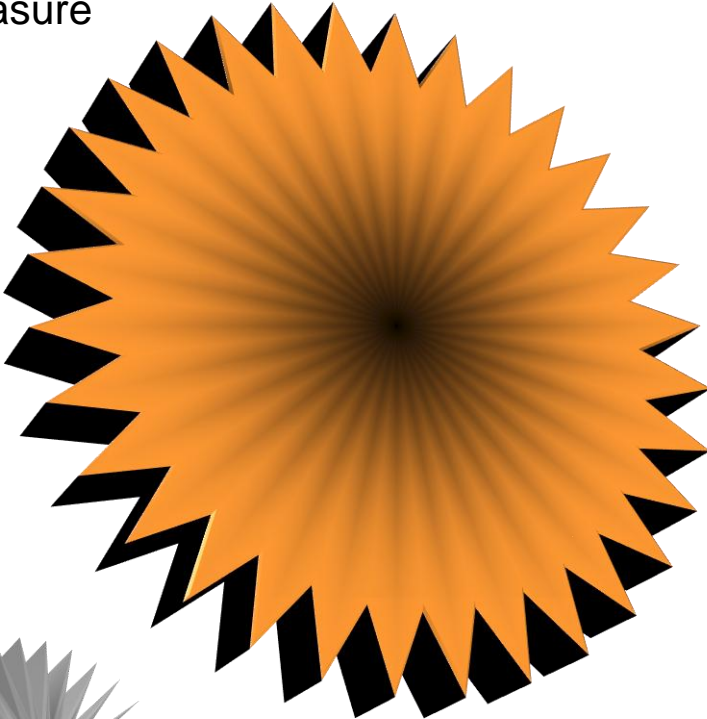

* Footnote

Source: Source

WIRE CUBES

Unit of measure

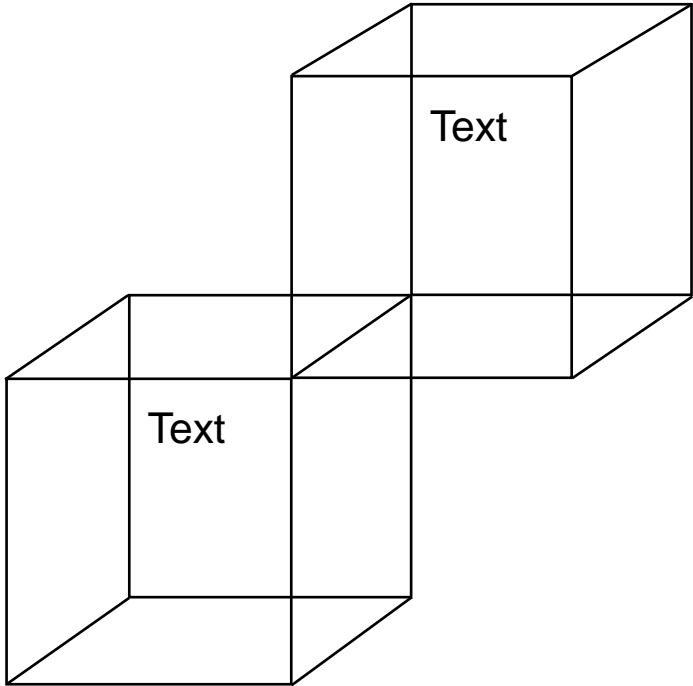

* Footnote

ARROWS

Unit of measure

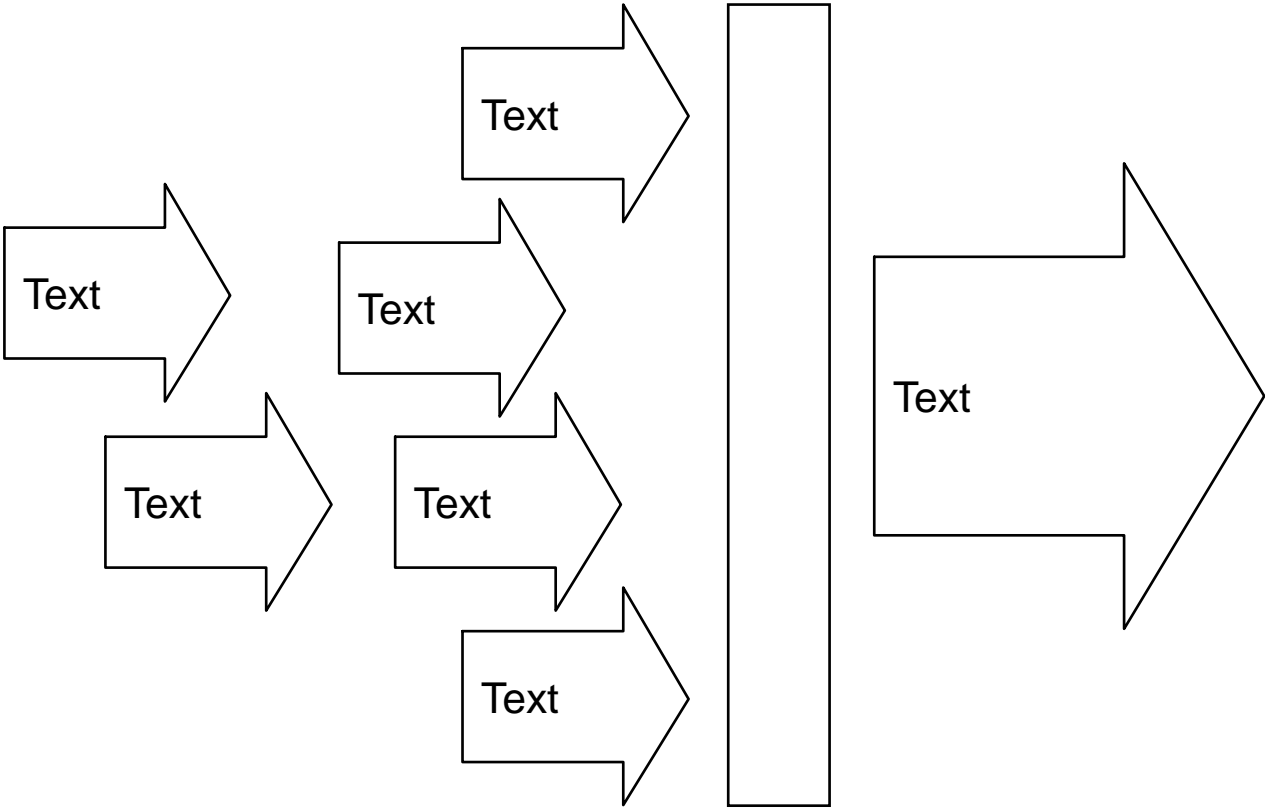

* Footnote

LEVEL 1

Unit of measure

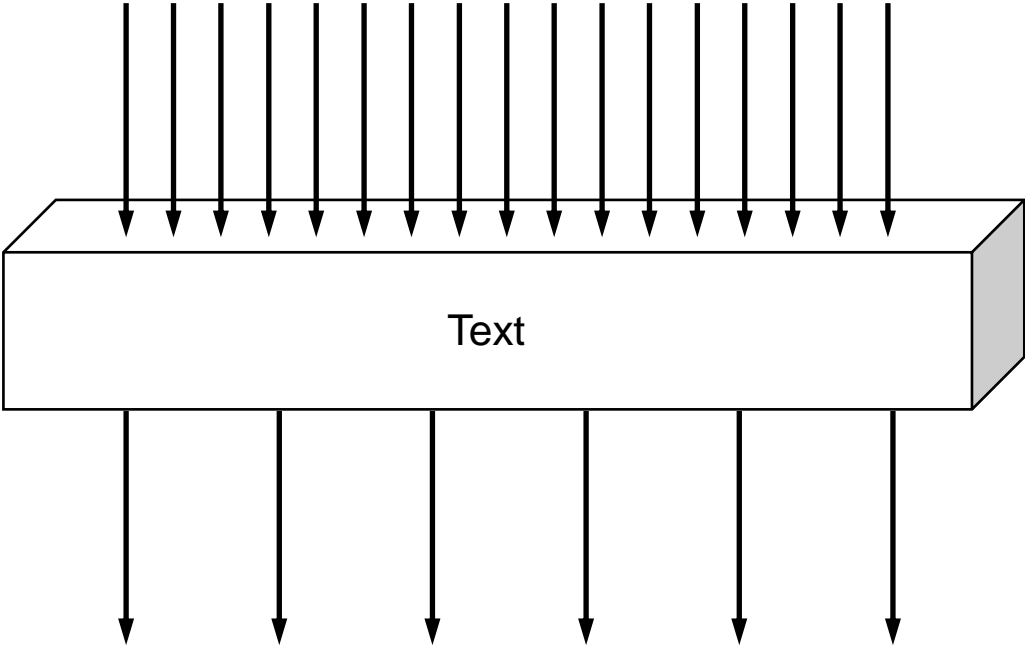

* Footnote

LEVEL 2

Unit of measure

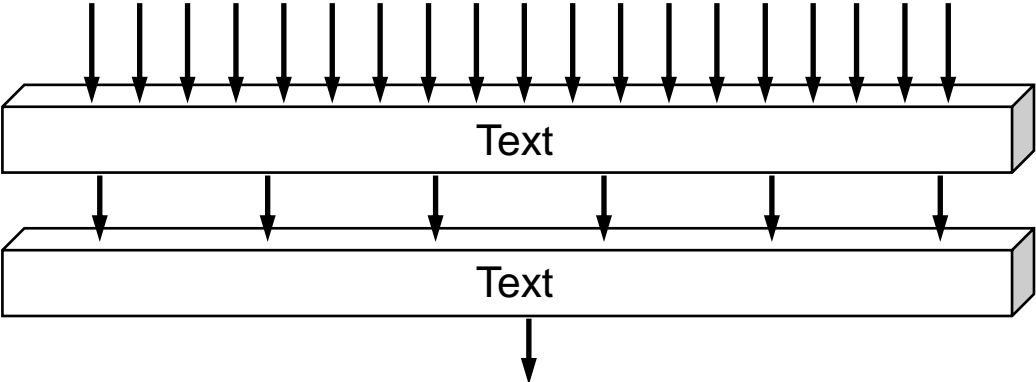

* Footnote

LEVEL 3

Unit of measure

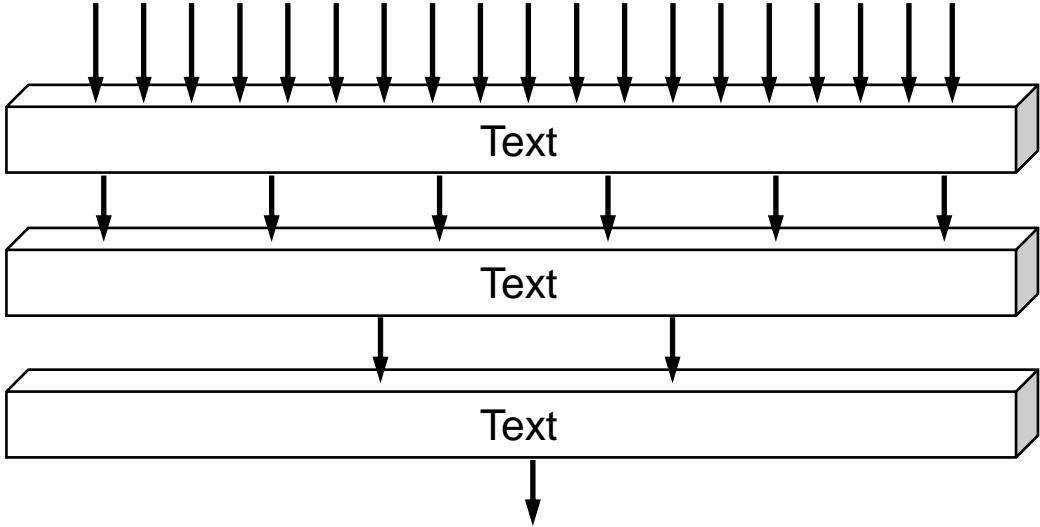

* Footnote

LEVEL 4

Unit of measure

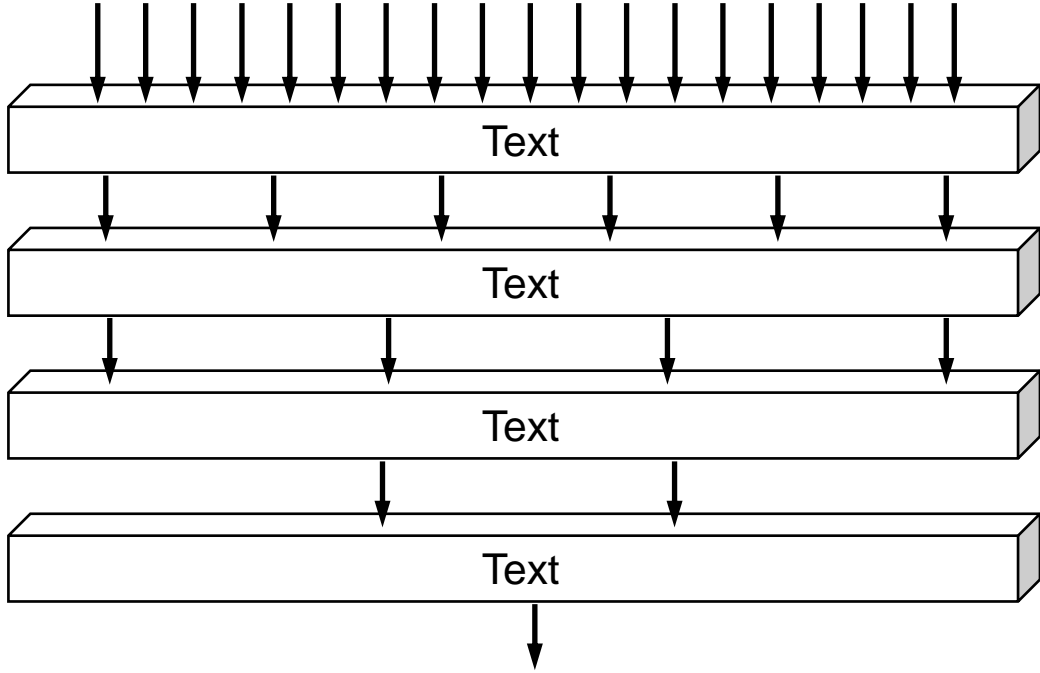

* Footnote

LEVEL 5

Unit of measure

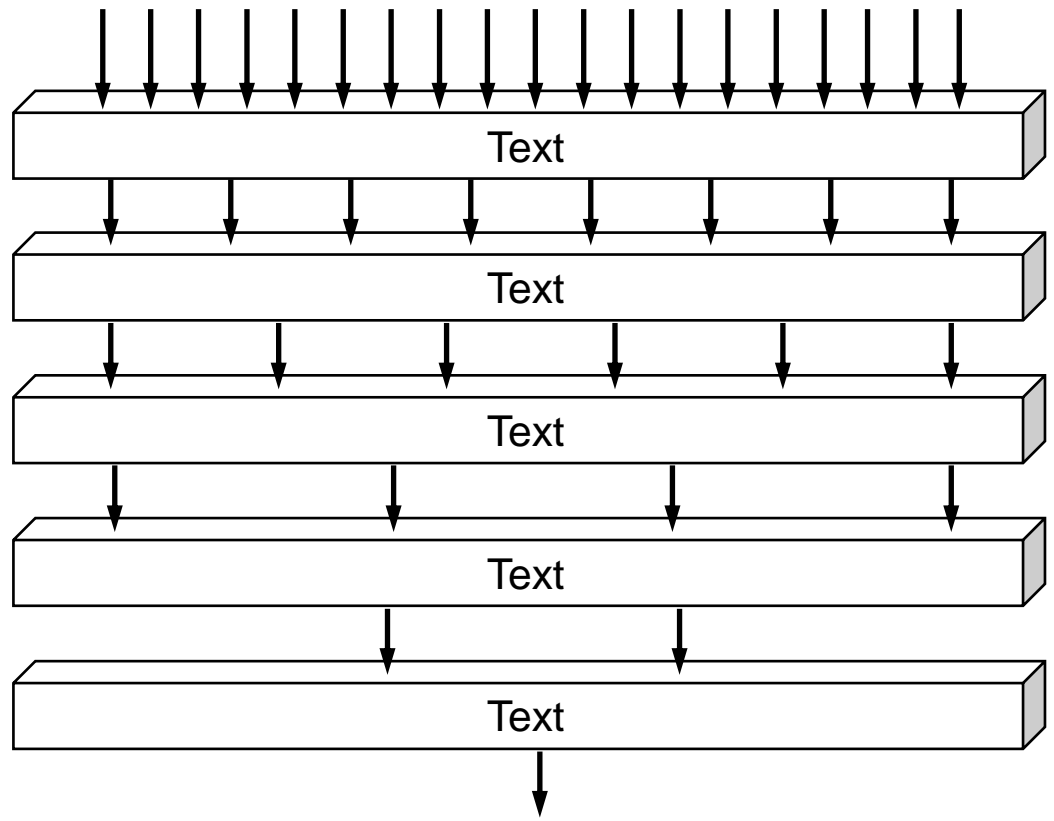

* Footnote

LEVEL 6

Unit of measure

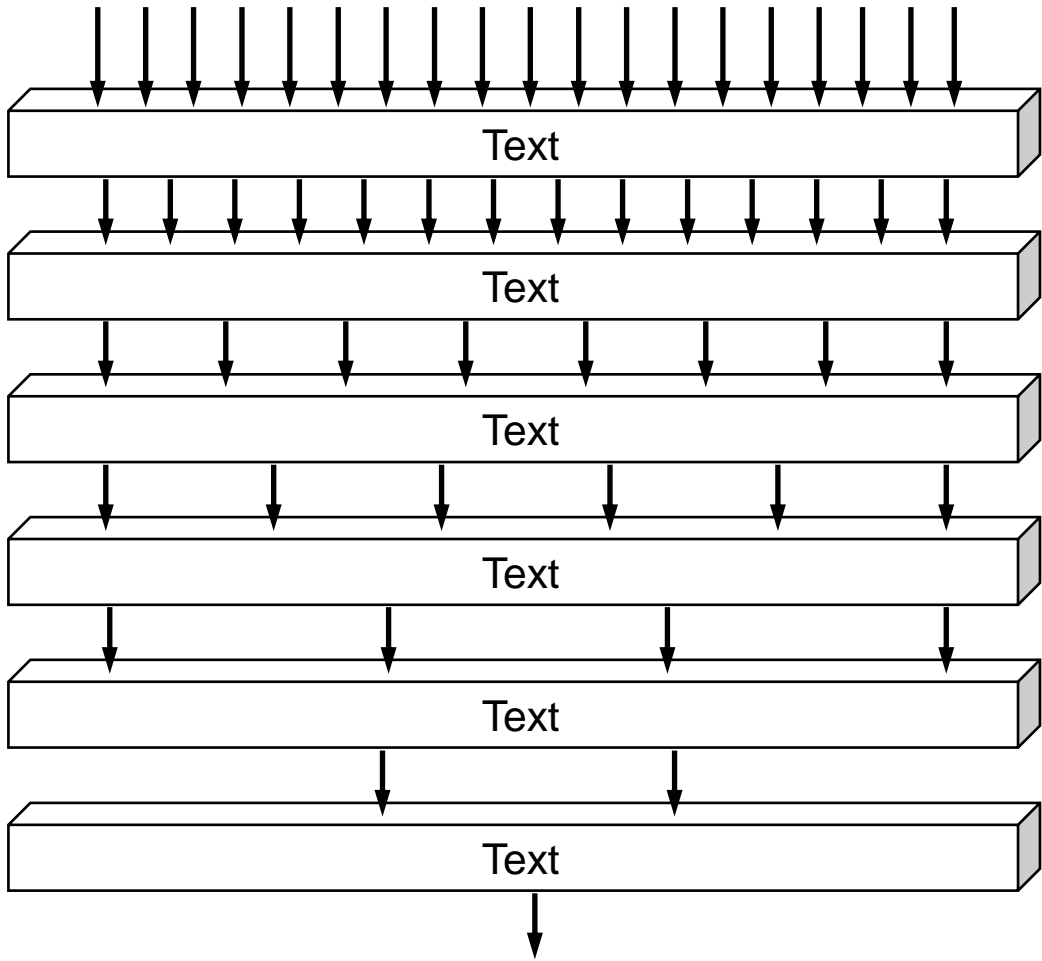

* Footnote

FLOW 2

Unit of measure

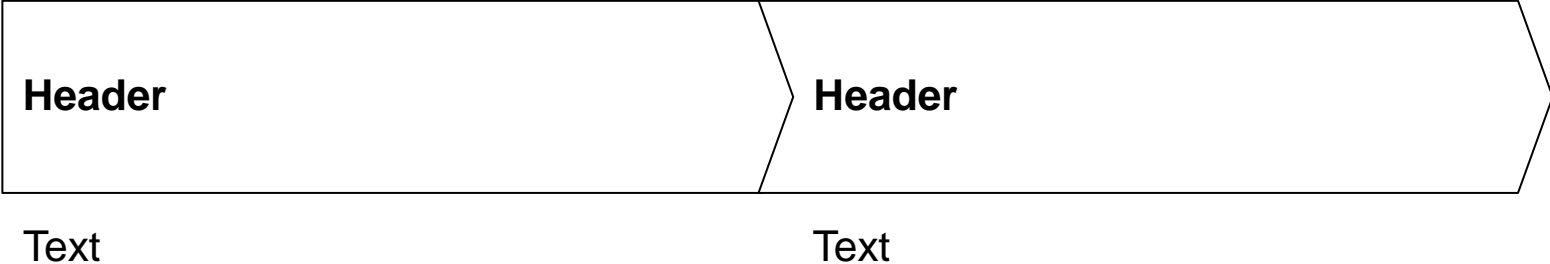

* Footnote

FLOW 2 TITLE

Unit of measure

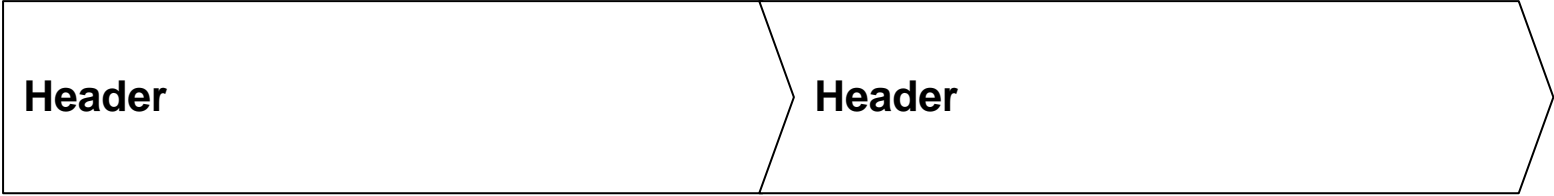

Text

Text

Text

* Footnote

FLOW 3

Unit of measure

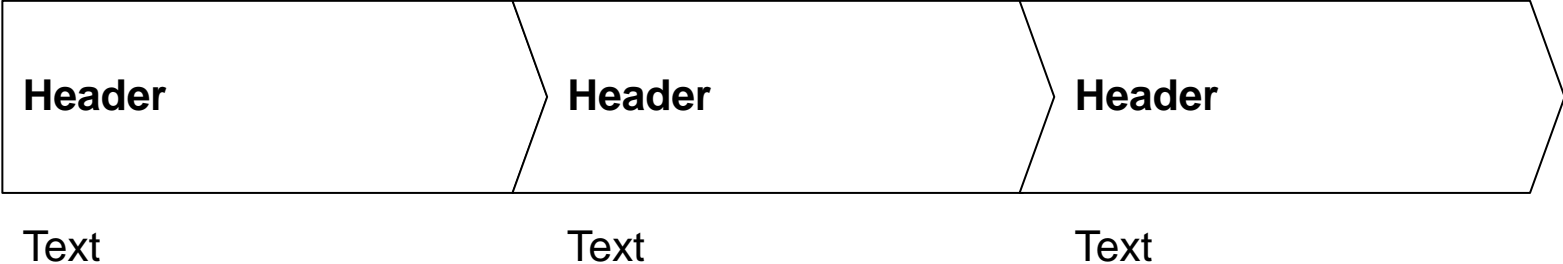

* Footnote

FLOW 3 TITLE

Unit of measure



Text

Text

Text

Text

* Footnote

FLOW 4

Unit of measure

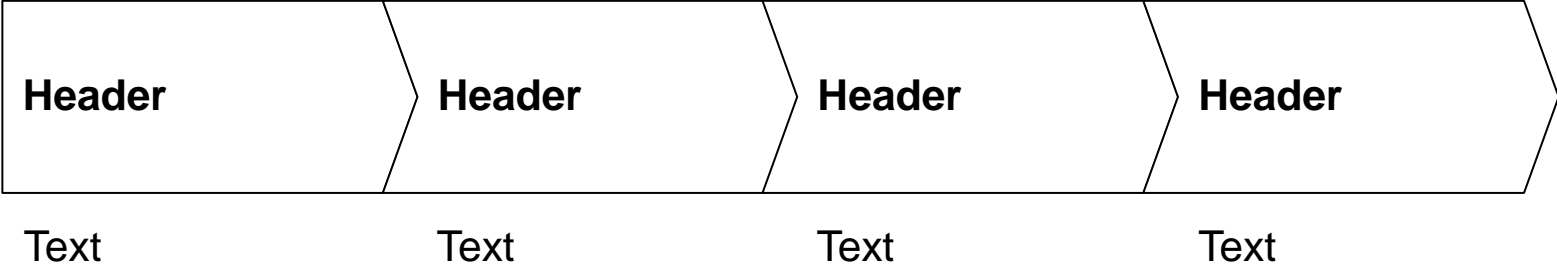

* Footnote

FLOW 4 TITLE

Unit of measure



Text

Text

Text

Text

Text

* Footnote

FLOW 5

Unit of measure

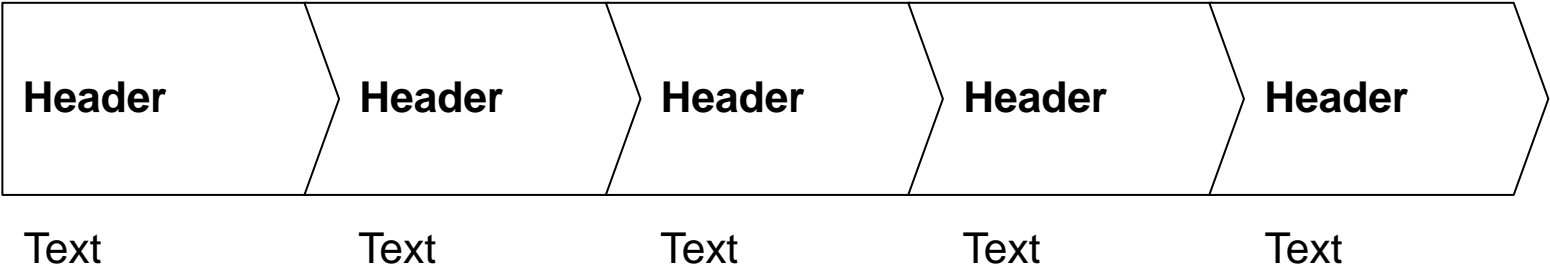

* Footnote

FLOW 5 TITLE

Unit of measure



Text

Text

Text

Text

Text

Text

* Footnote

FLOW 6

Unit of measure

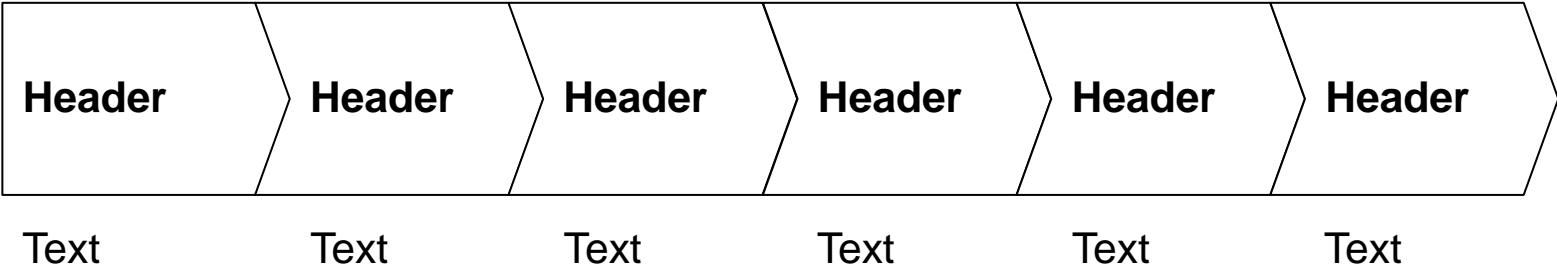

* Footnote

FLOW 6 TITLE

Unit of measure

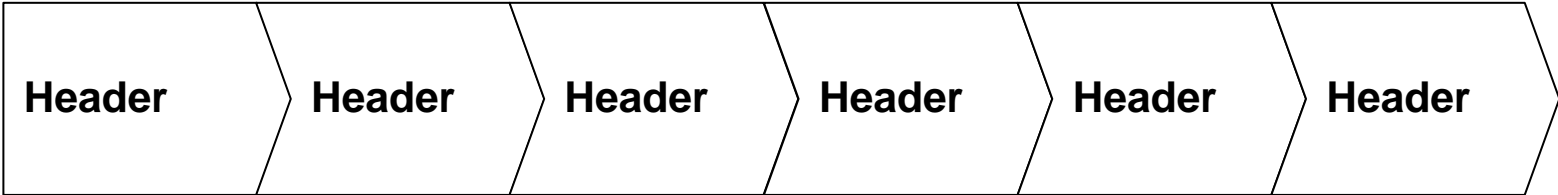

Text

Text

Text

Text

Text

Text

Text

* Footnote

BLADES

Unit of measure

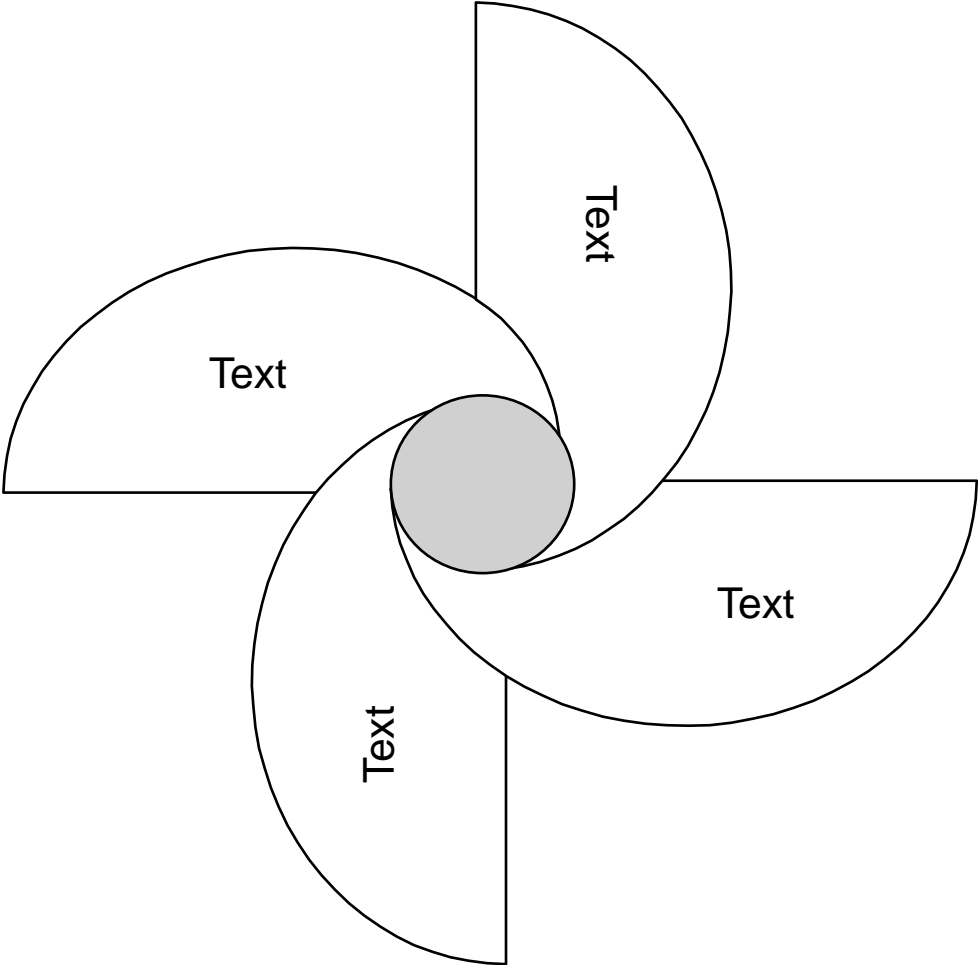

* Footnote

BOX

Unit of measure

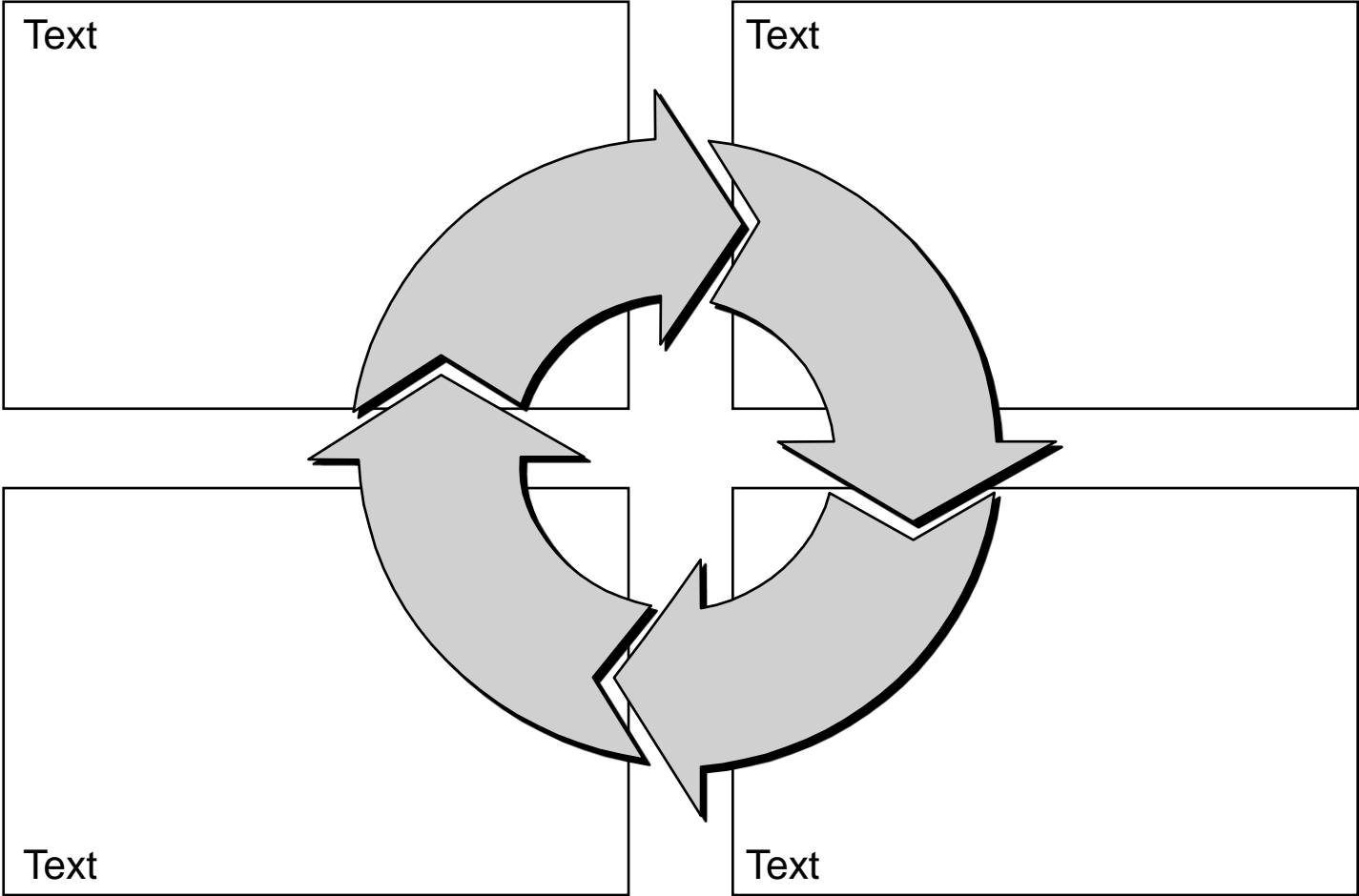

* Footnote

BOX

Unit of measure

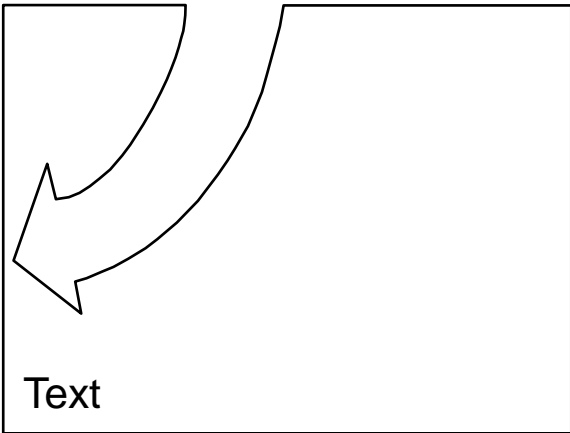
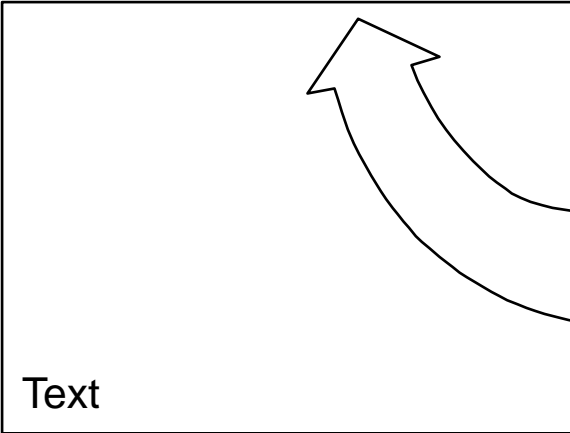
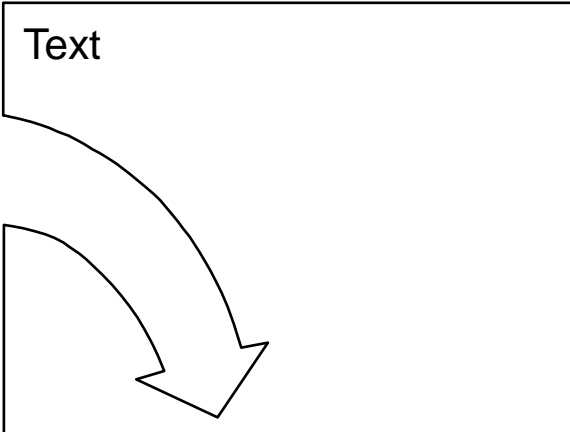
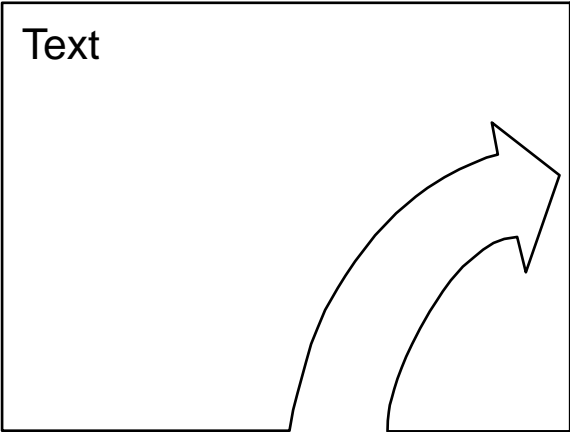

* Footnote

CYCLE 1

Unit of measure

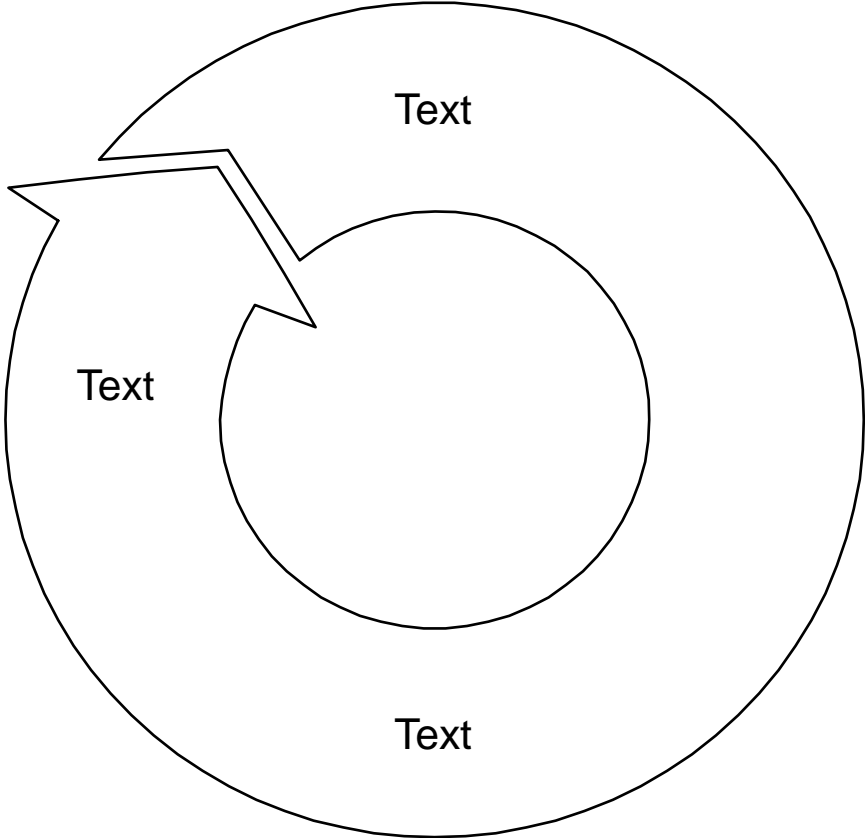

* Footnote

CYCLE 2

Unit of measure

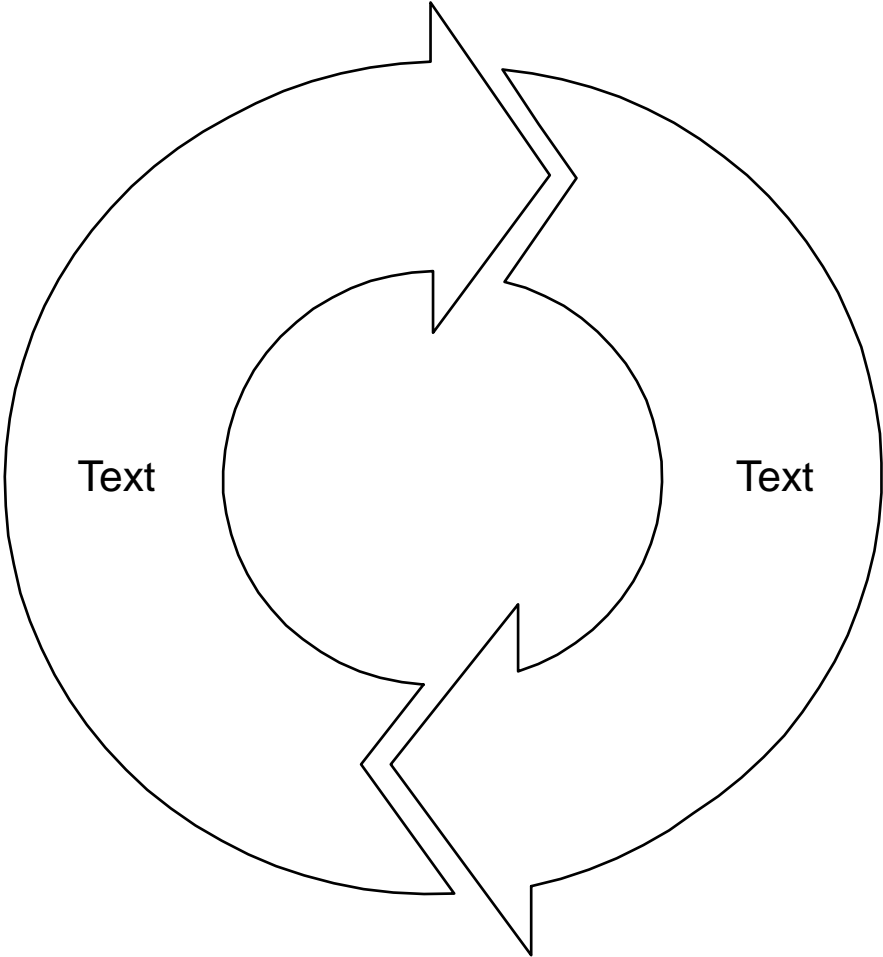

* Footnote

CYCLE 3

Unit of measure

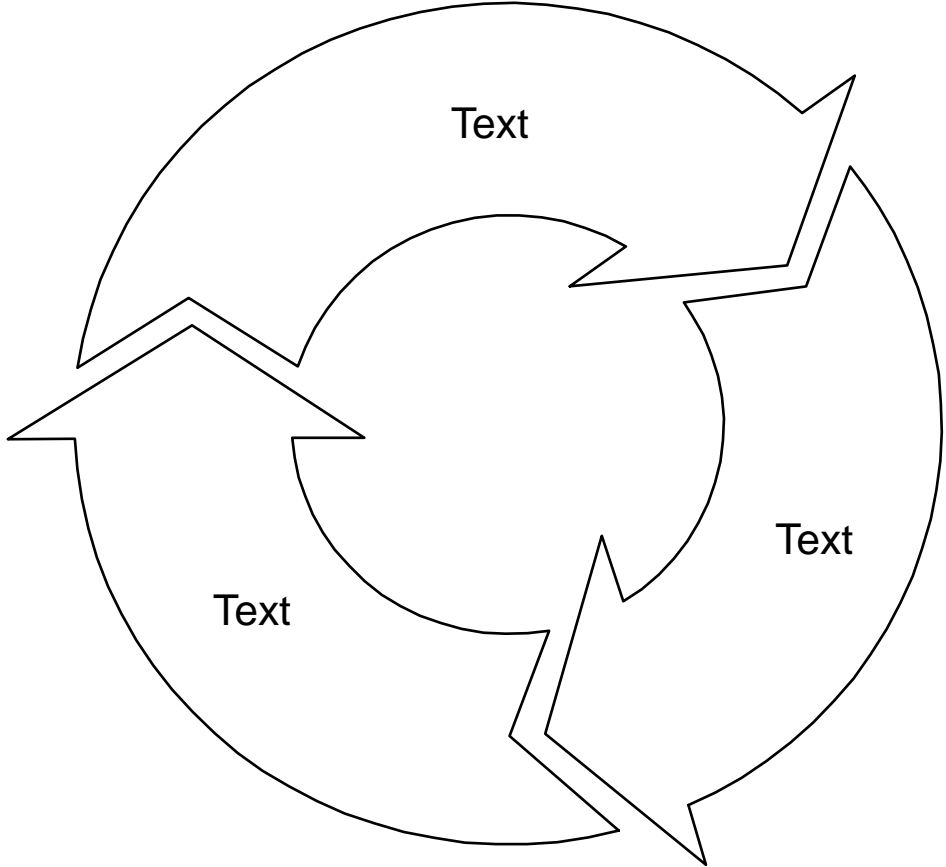

* Footnote

CYCLE 4

Unit of measure

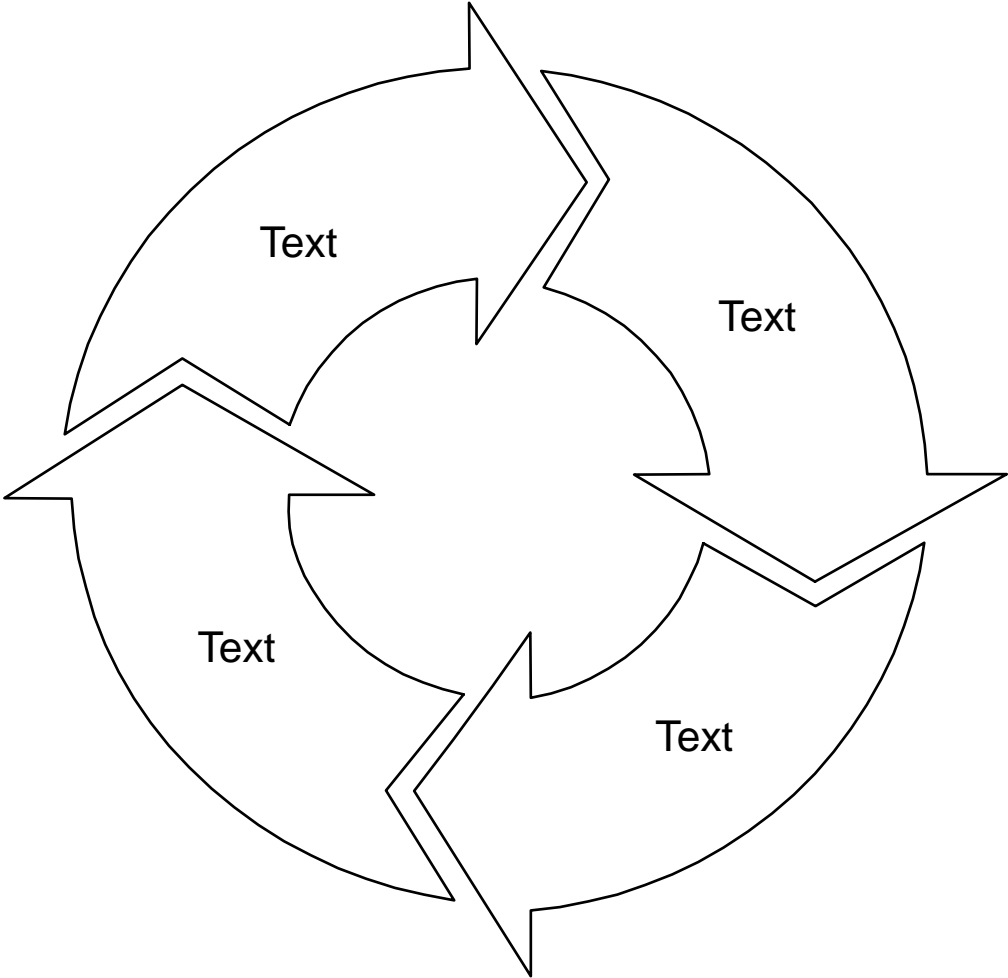

* Footnote

CYCLE 5

Unit of measure

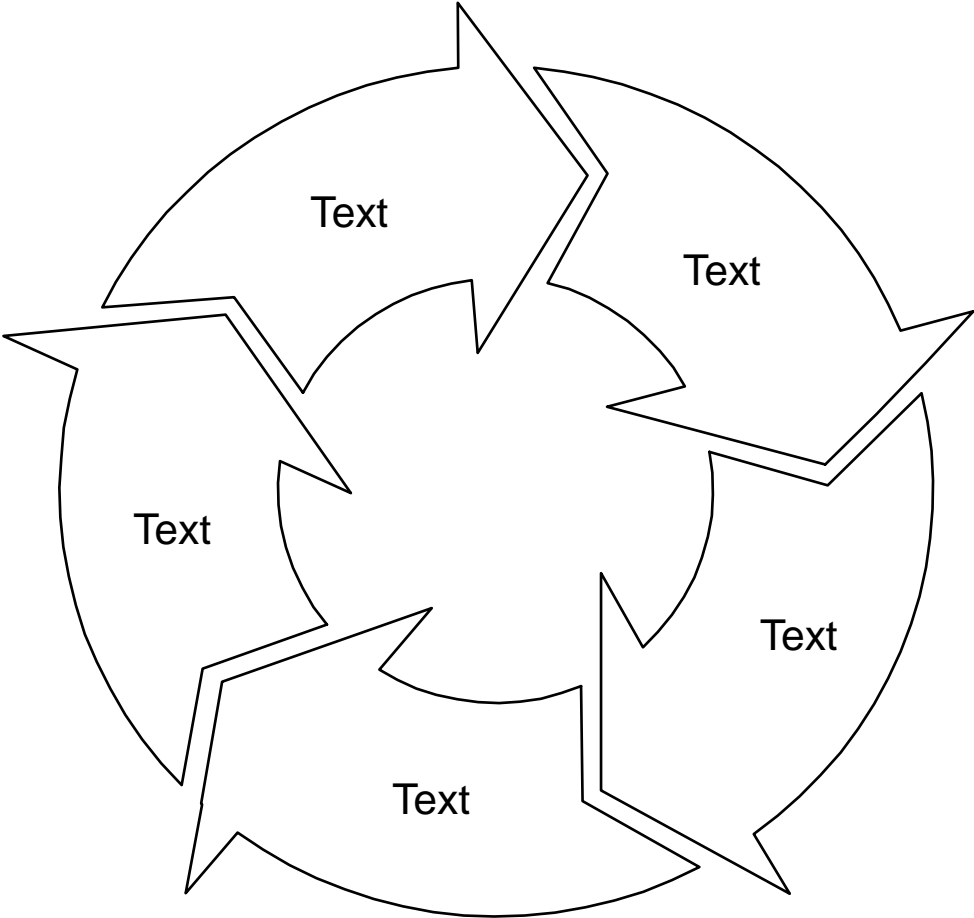

* Footnote

CYCLE 6

Unit of measure

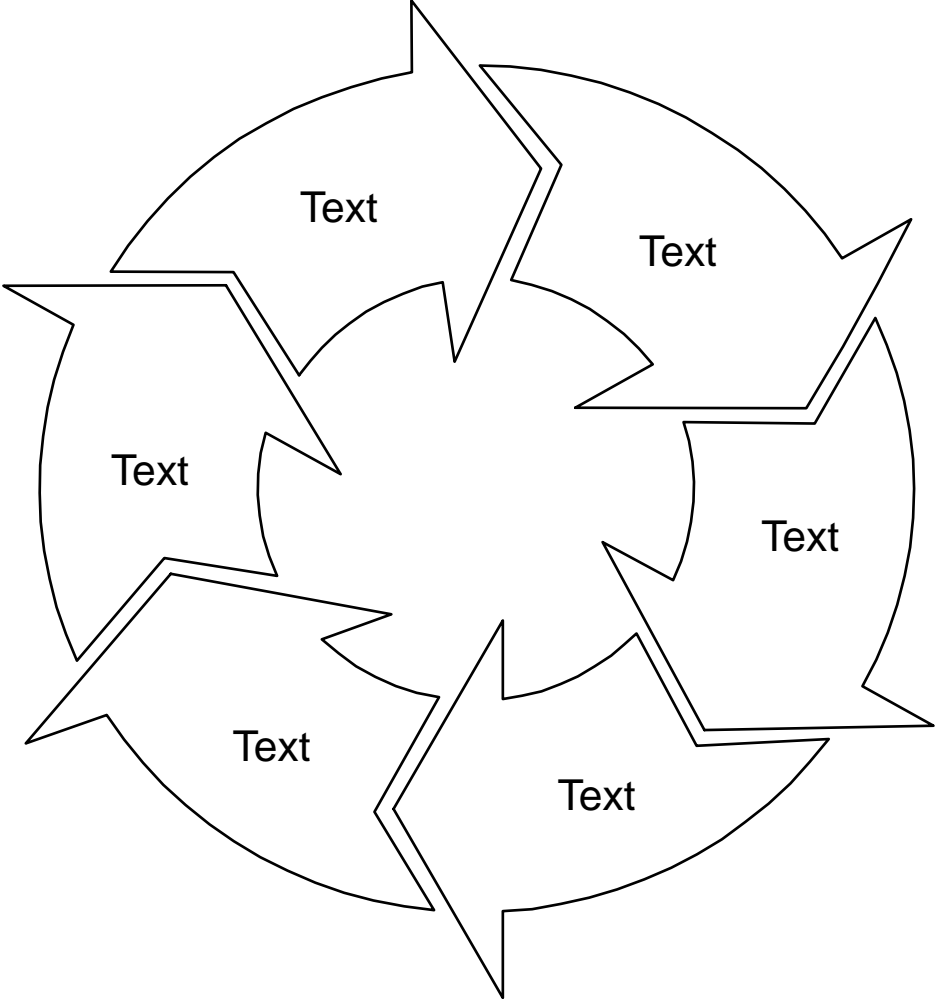

* Footnote

CYCLE 7

Unit of measure

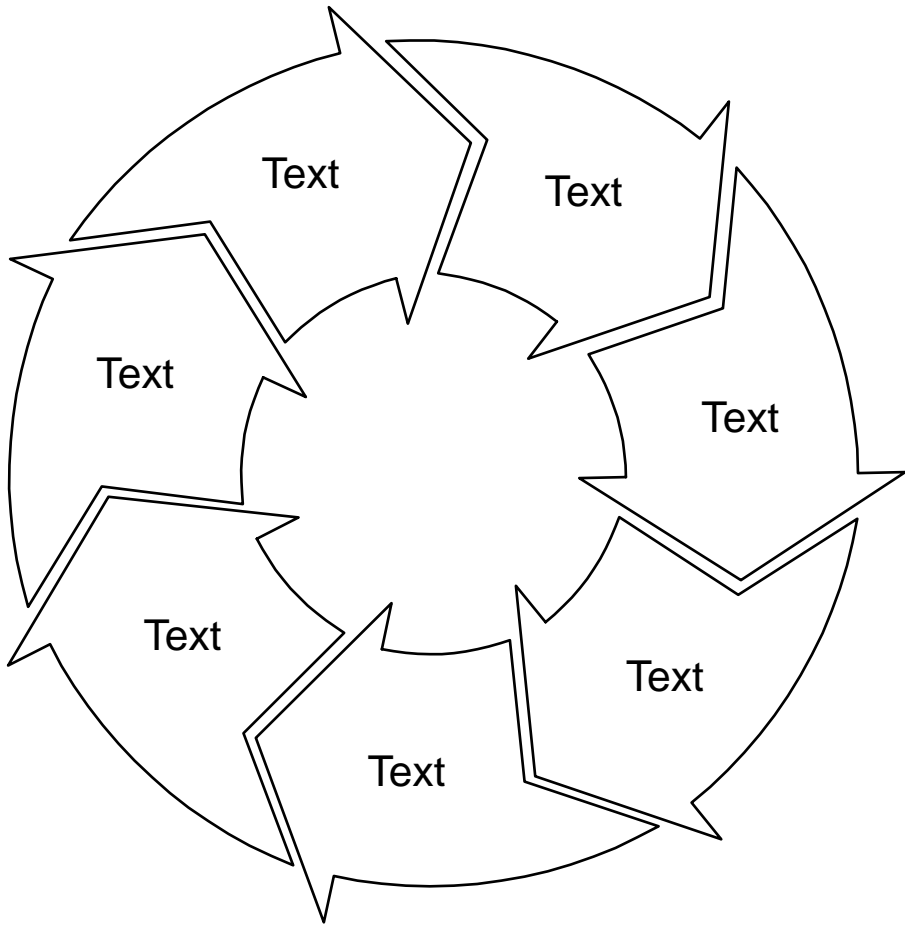

* Footnote

CYCLE 8

Unit of measure

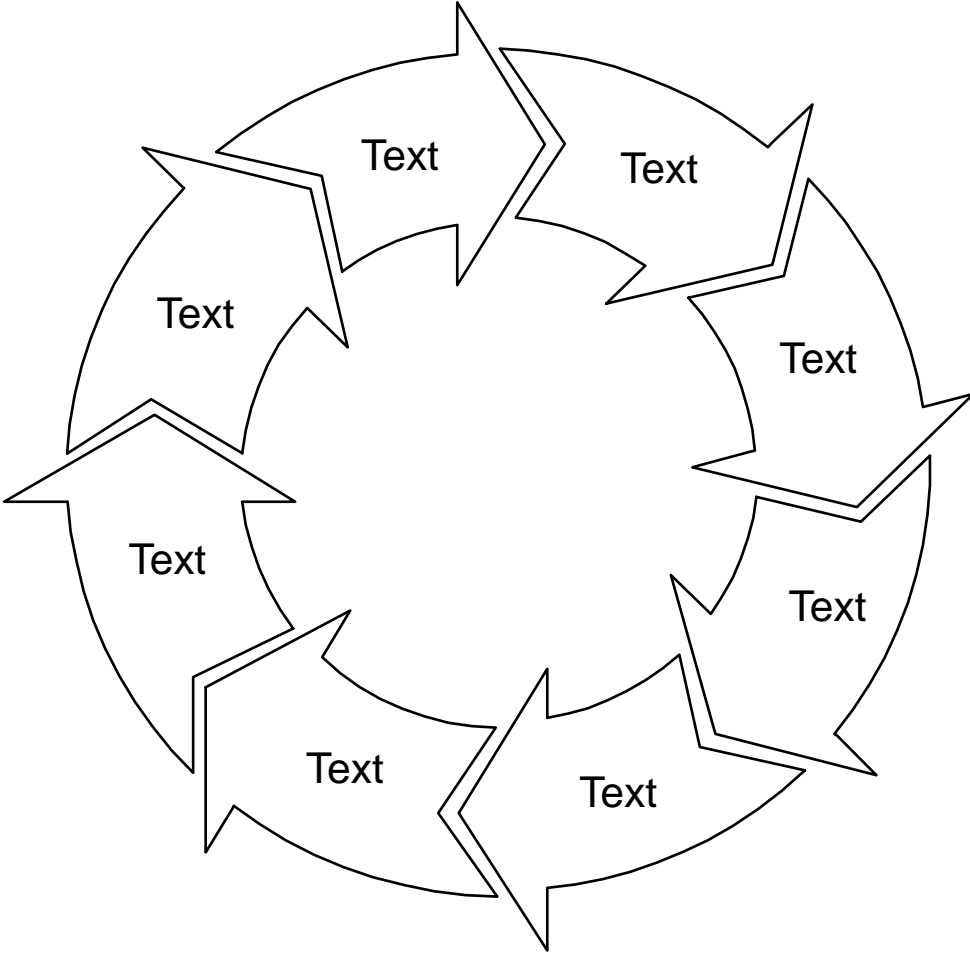

* Footnote

INCOMING

Unit of measure

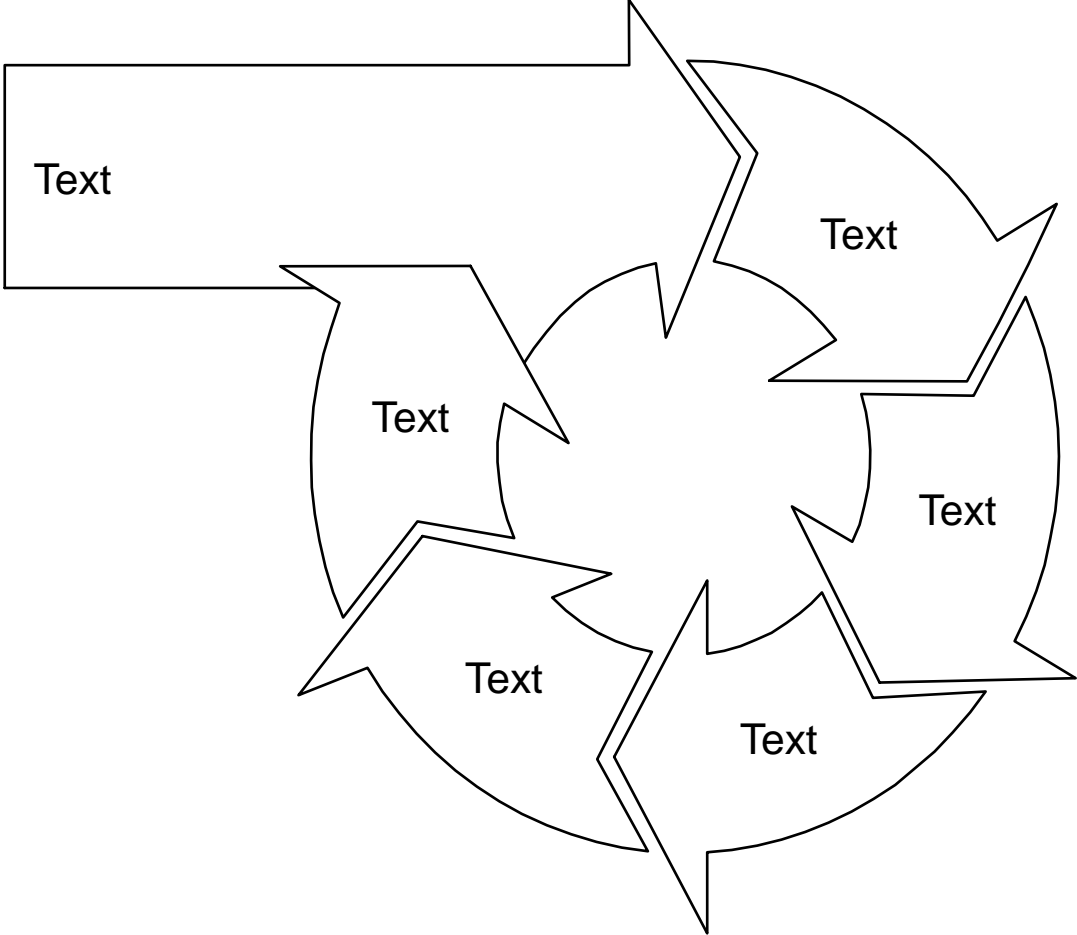

* Footnote

RIBBON

Unit of measure

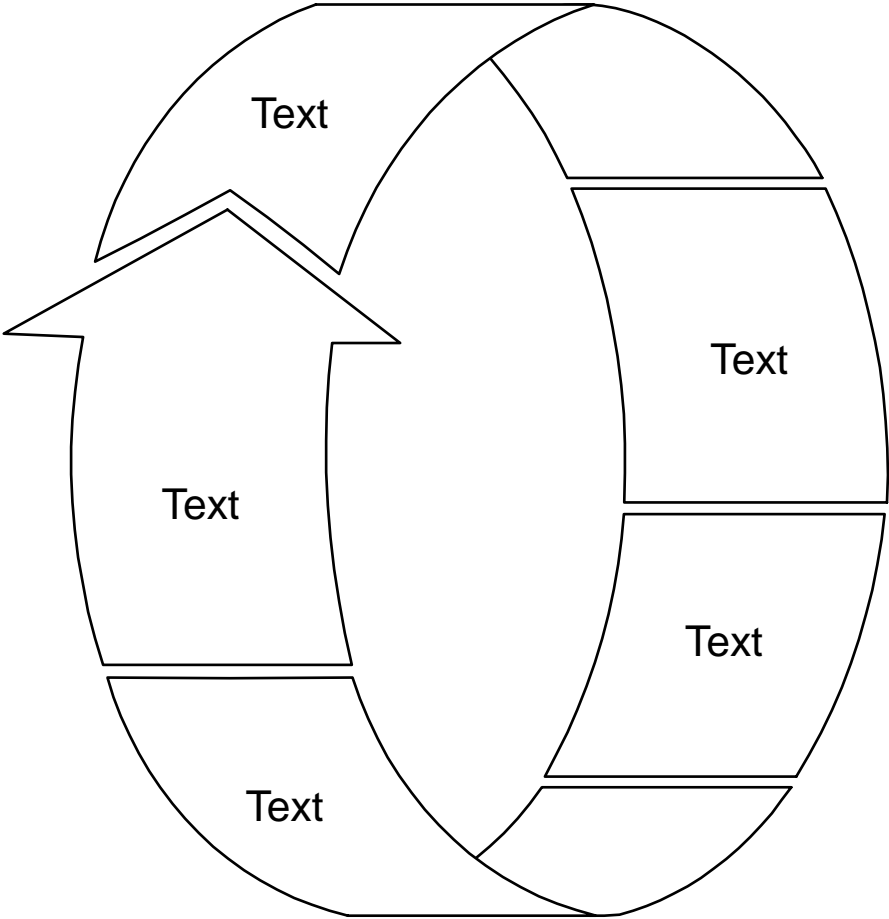

* Footnote

RING

Unit of measure

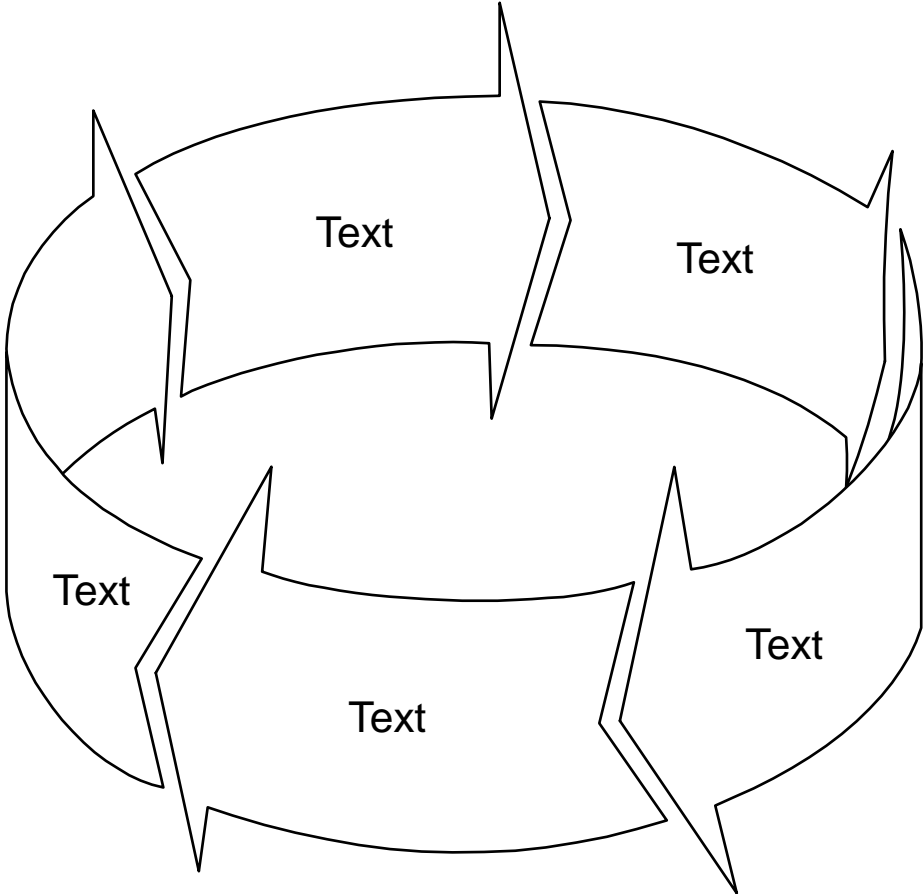

* Footnote

UPON 2

Unit of measure

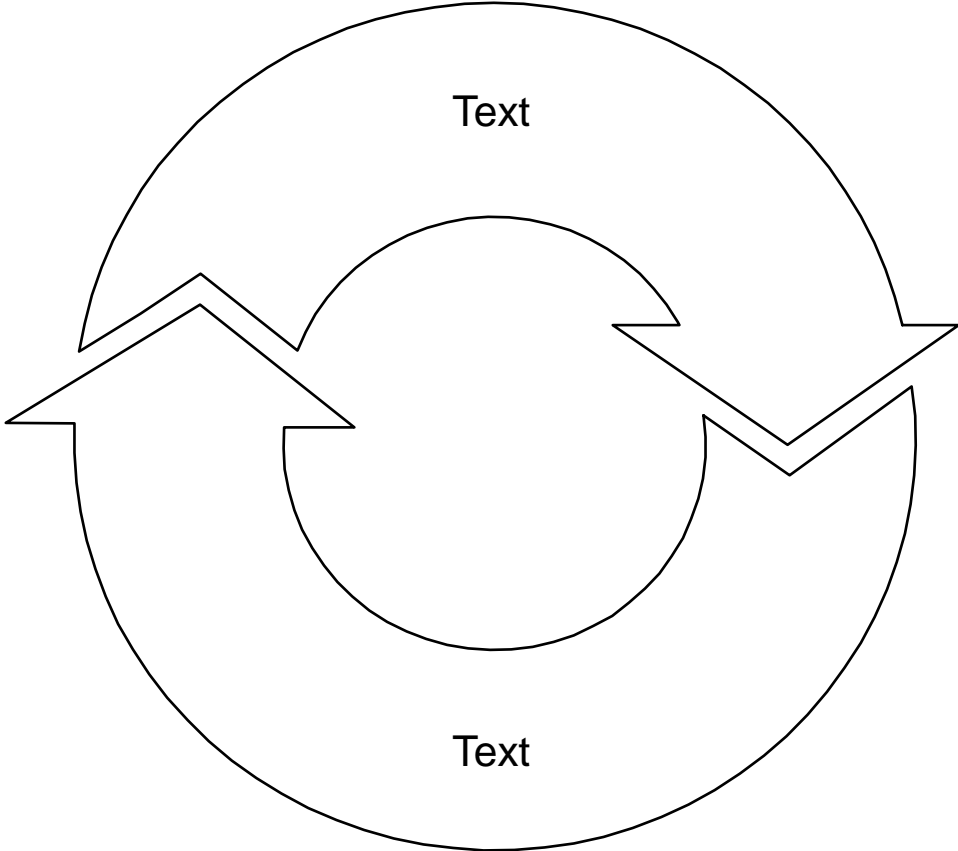

* Footnote

CONTINUOUS

Unit of measure

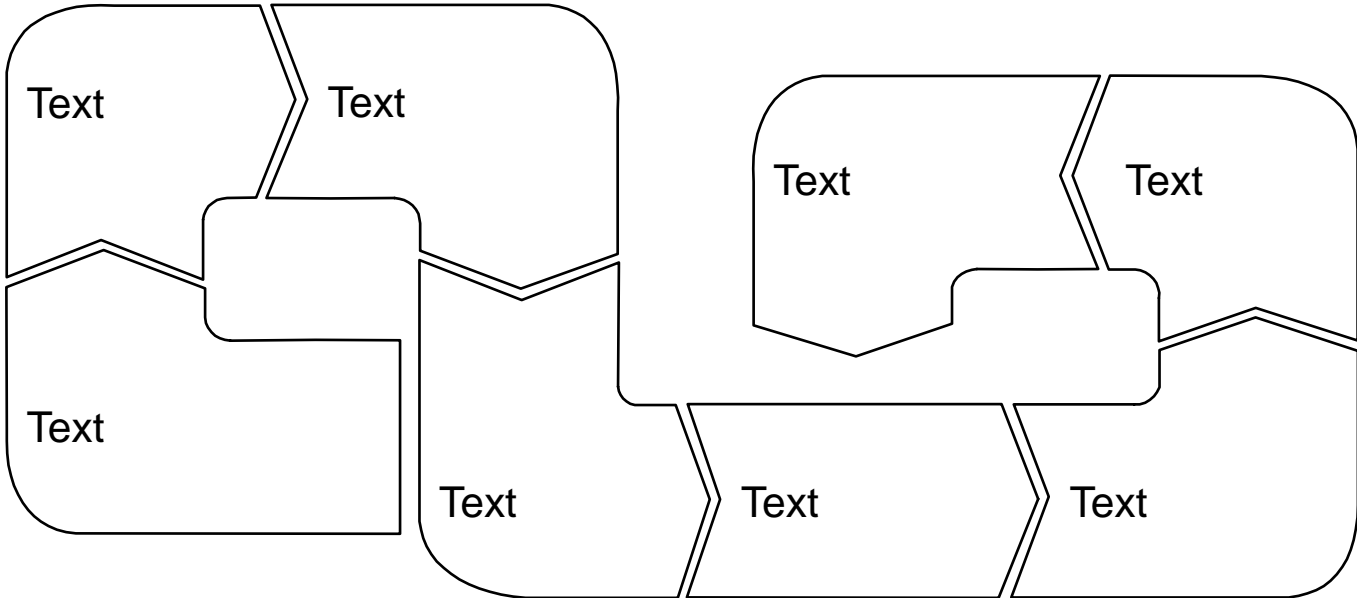

* Footnote

CUTOUT

Unit of measure

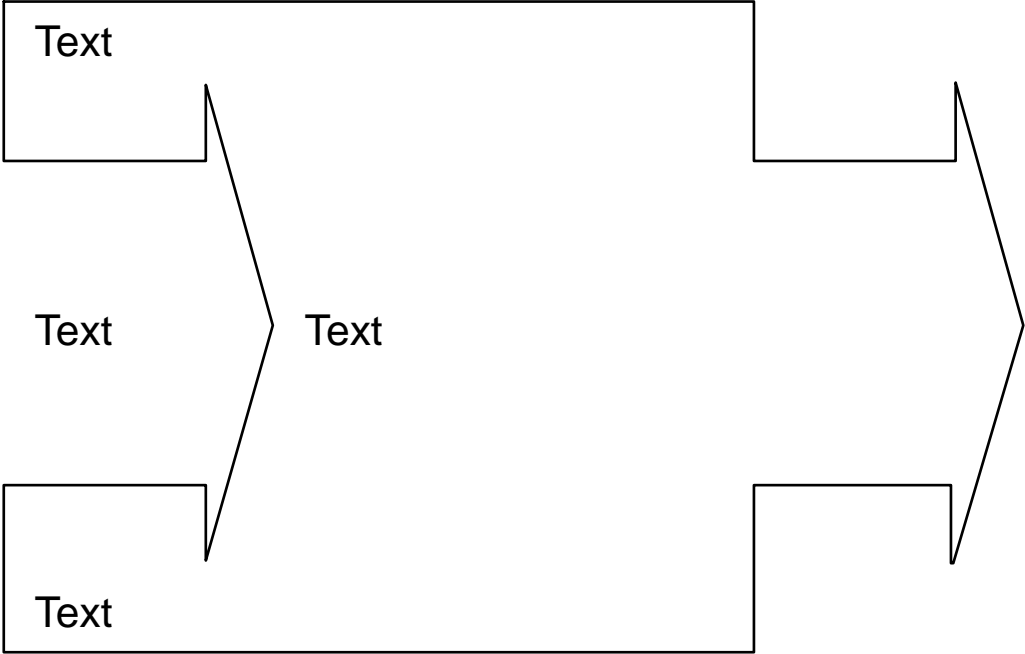

* Footnote

LINEAR A

Unit of measure

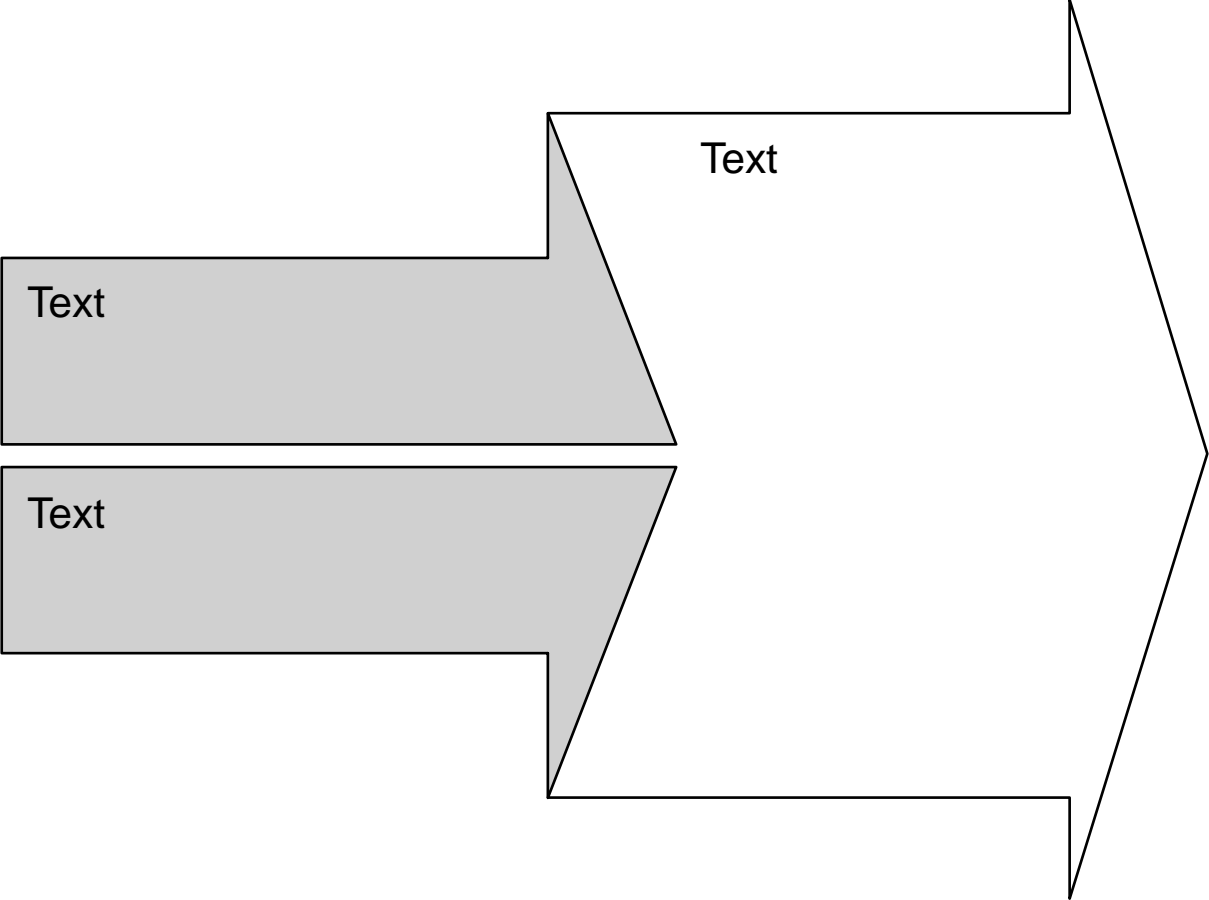

* Footnote

LINEAR B

Unit of measure

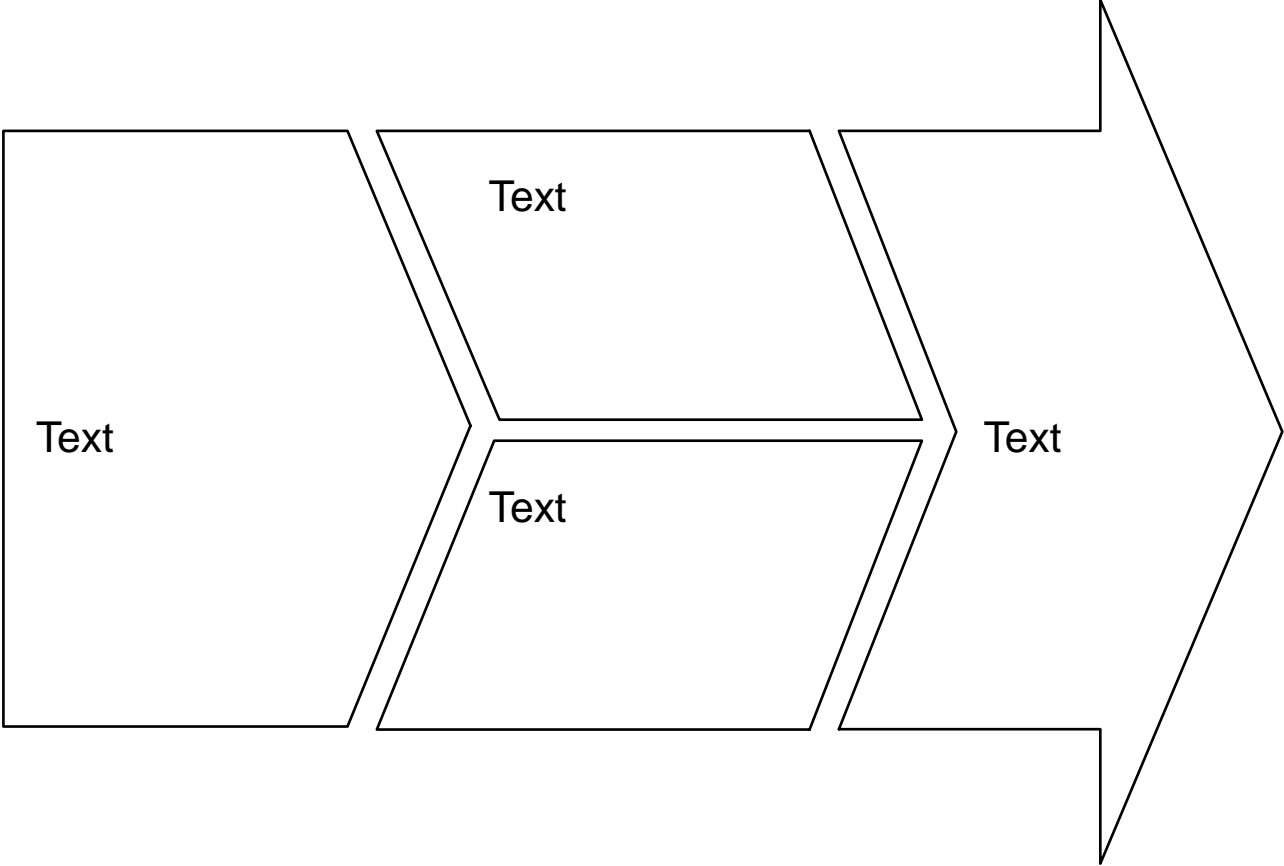

* Footnote

LINEAR C

Unit of measure

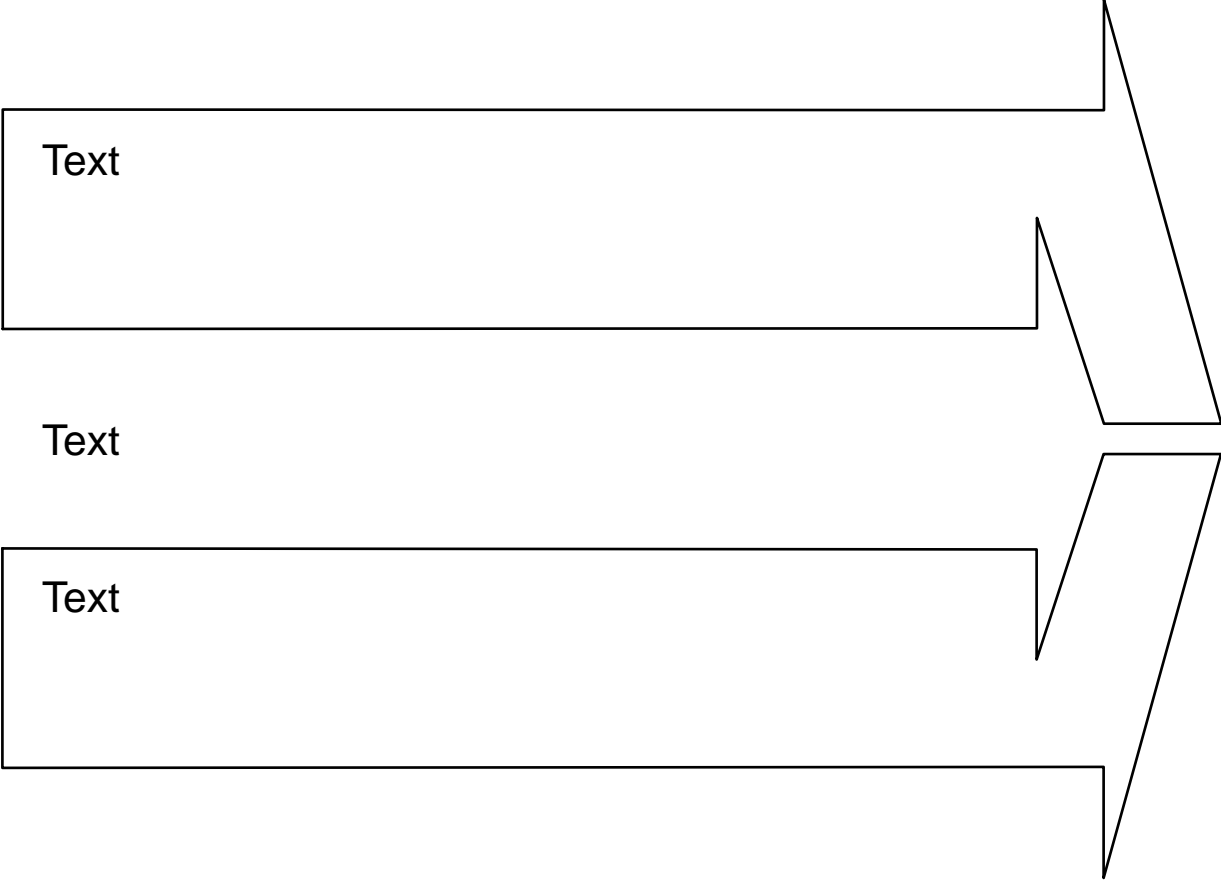

* Footnote

LINEAR D

Unit of measure

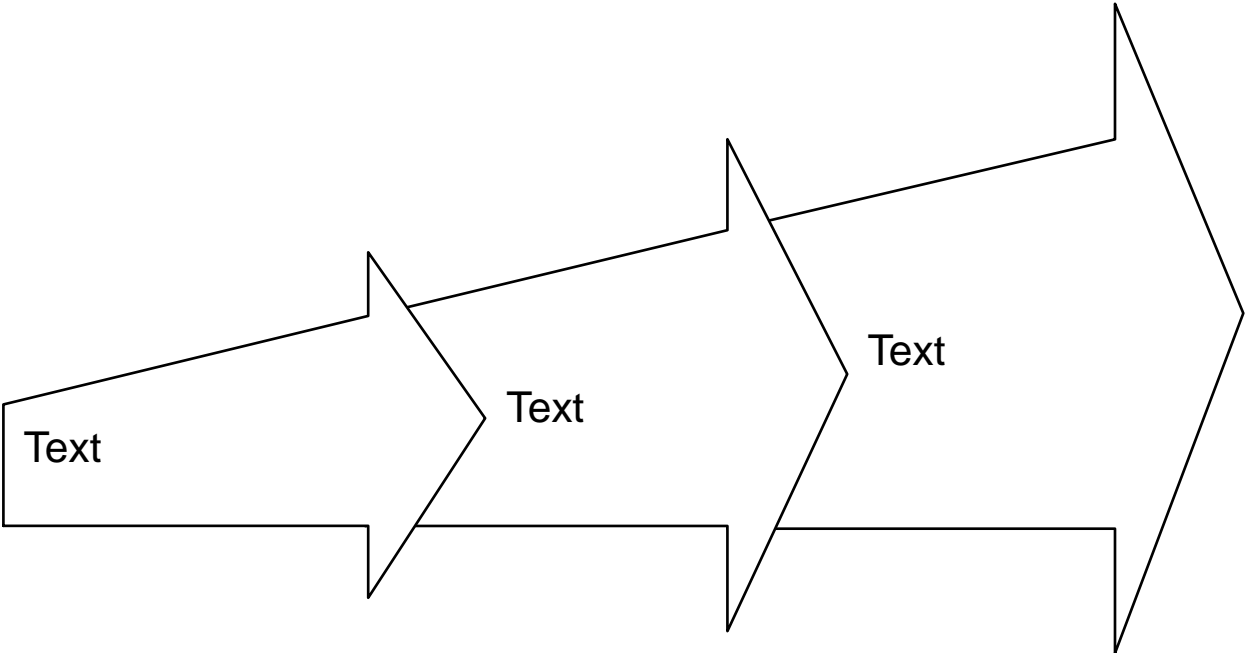

* Footnote

LINEAR E

Unit of measure

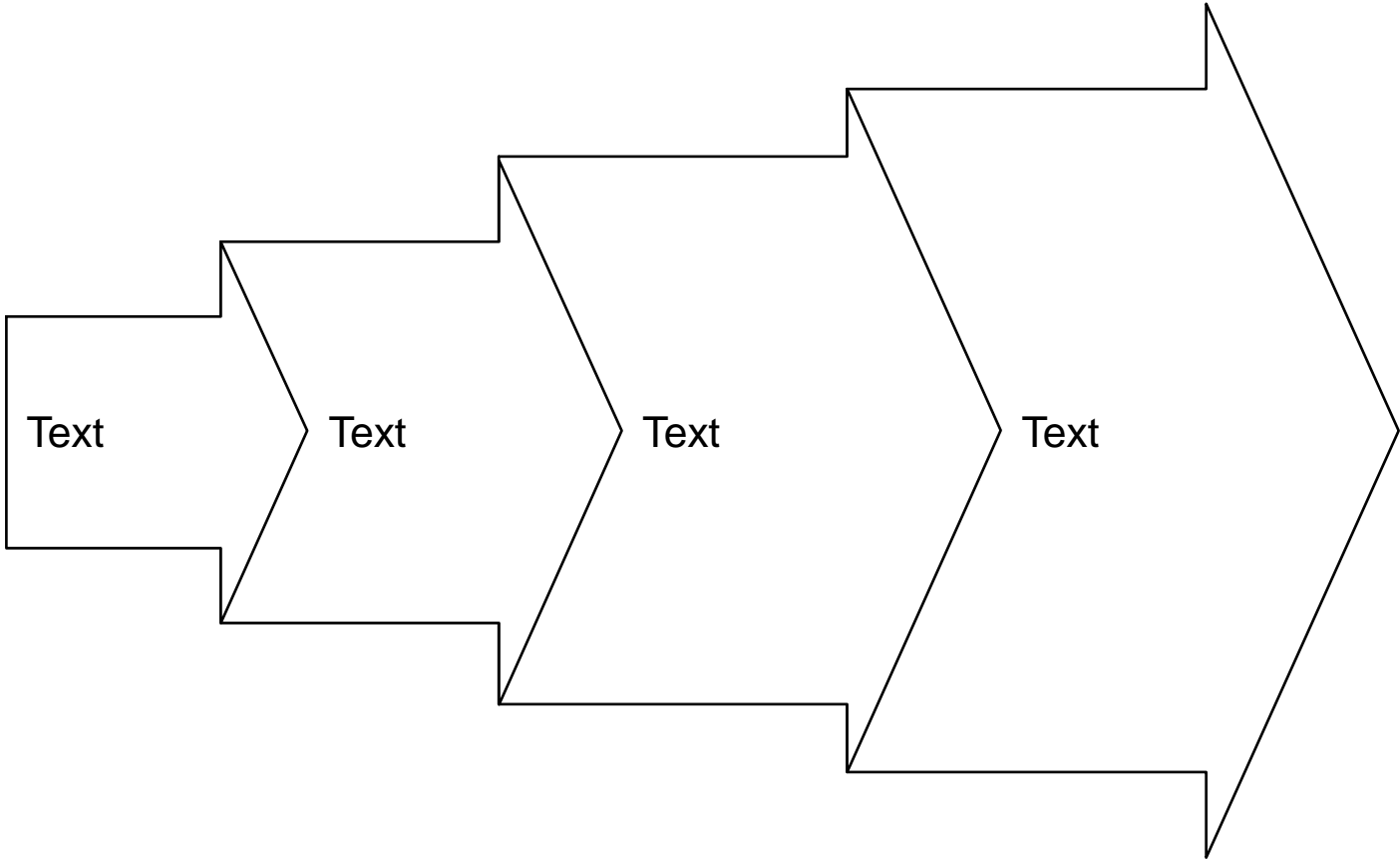

* Footnote

LINEAR F

Unit of measure

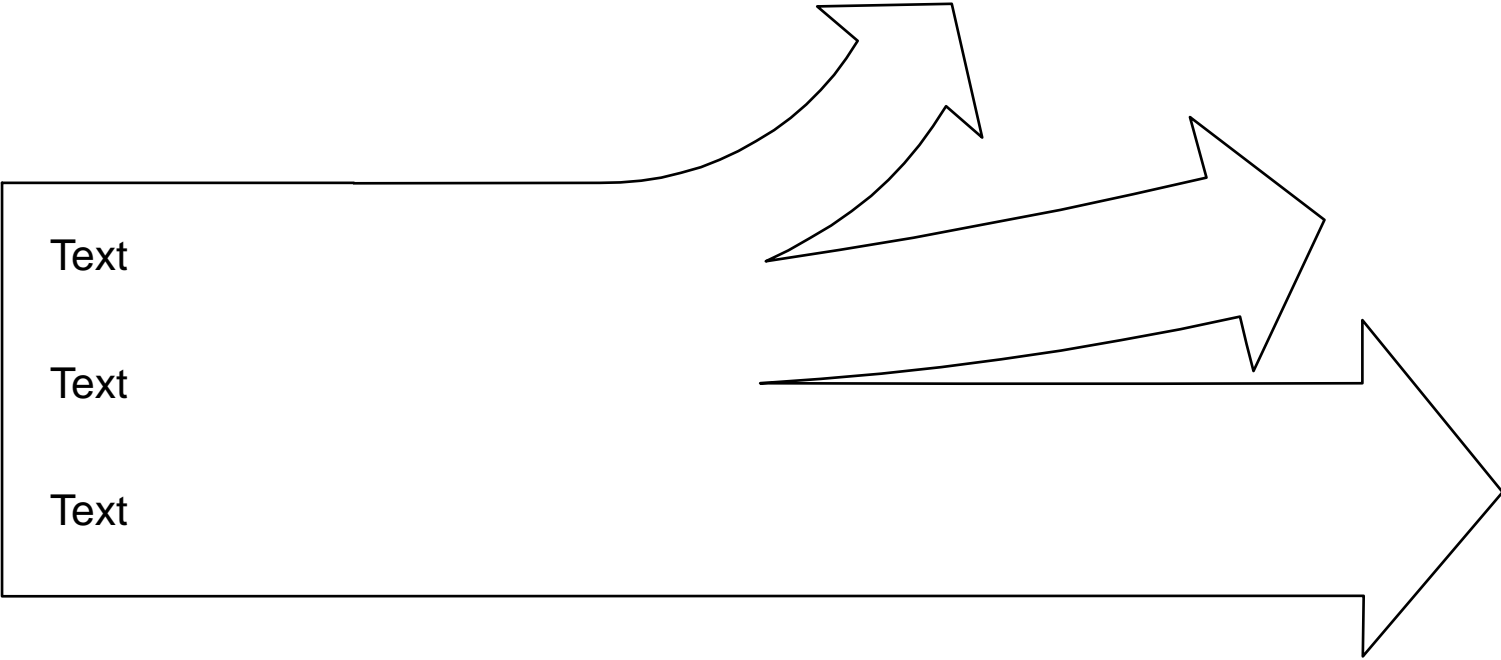

* Footnote

LINEAR G

Unit of measure

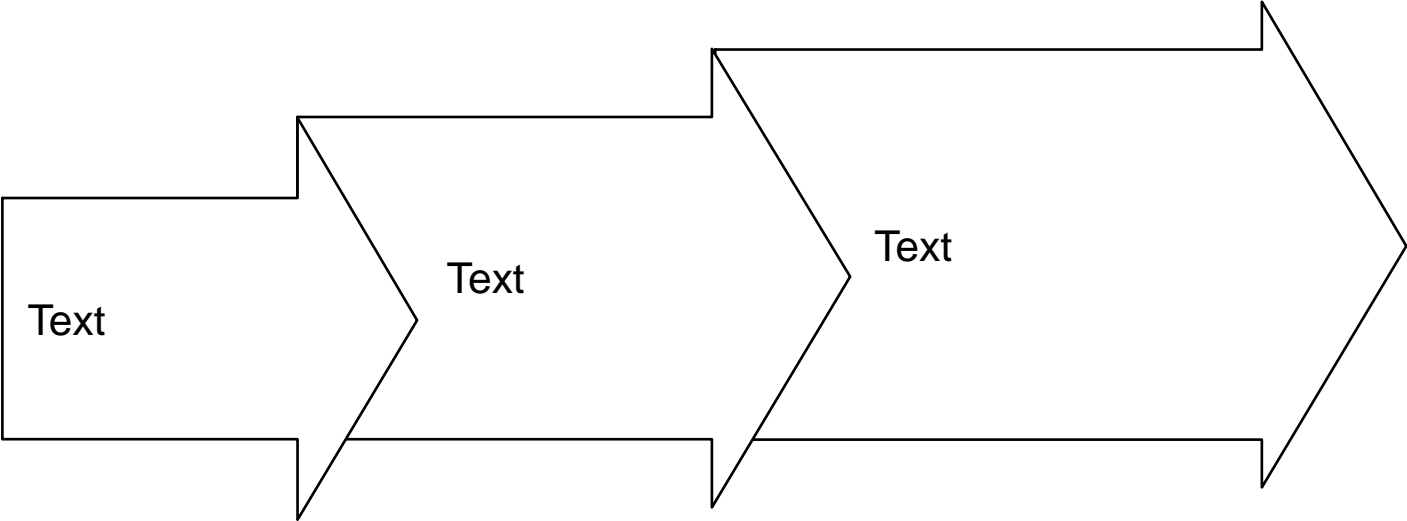

* Footnote

LINEAR H

Unit of measure

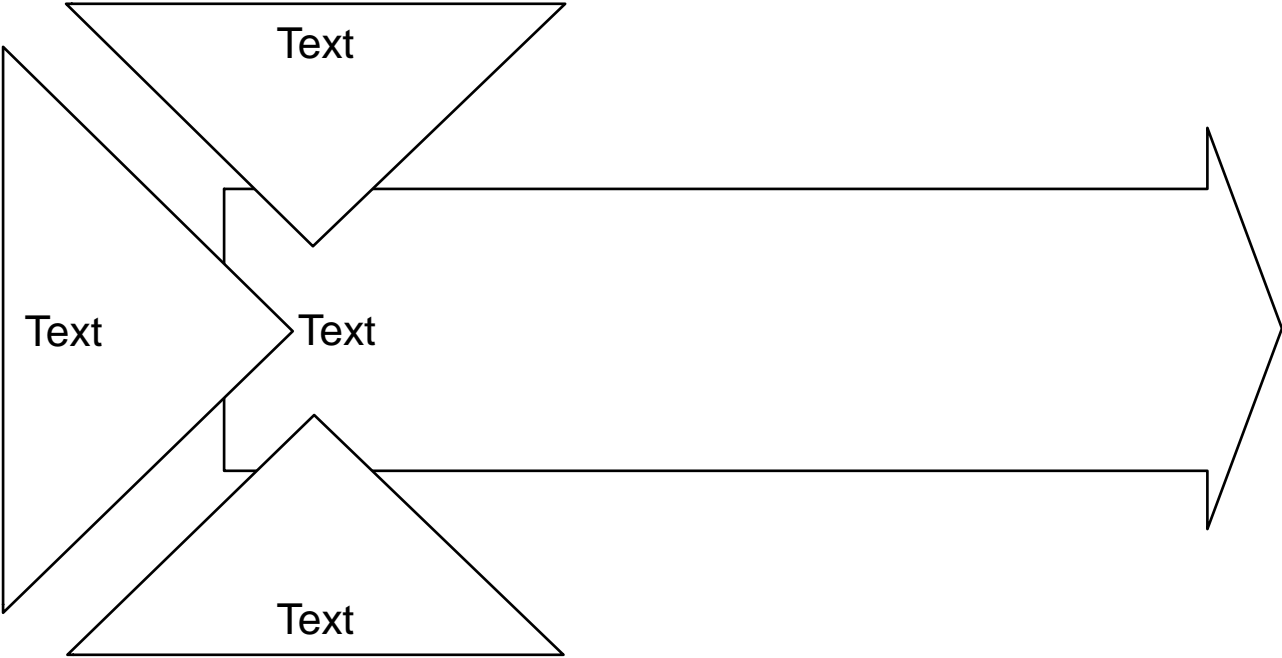

* Footnote

LINEAR I

Unit of measure

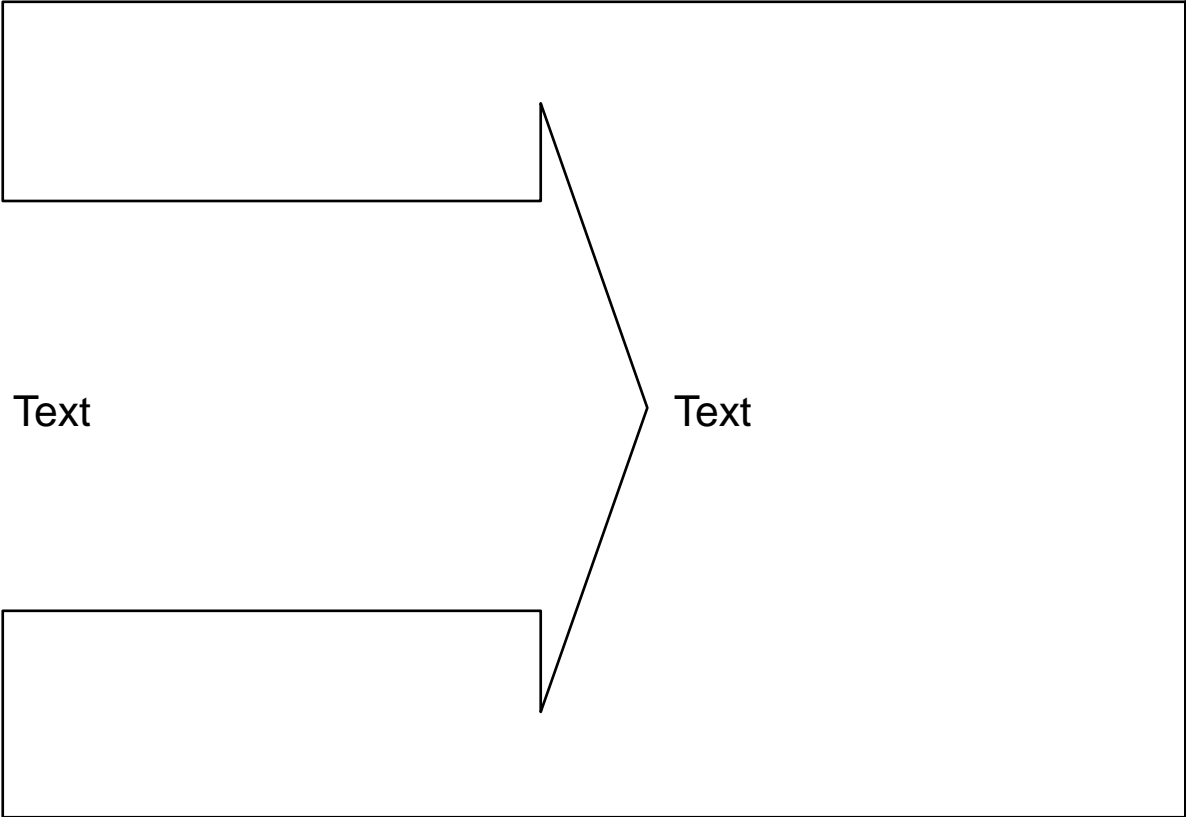

* Footnote

LINEAR J

Unit of measure

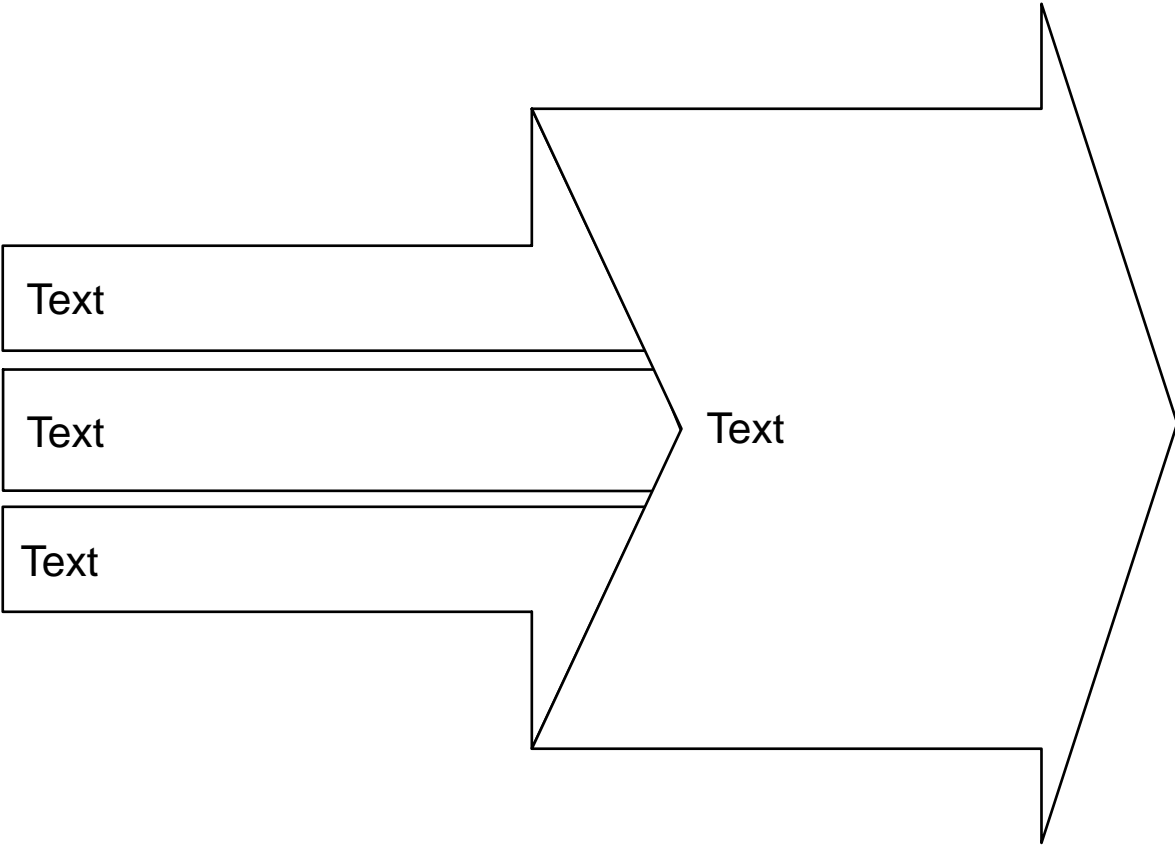

* Footnote

LINEAR K

Unit of measure

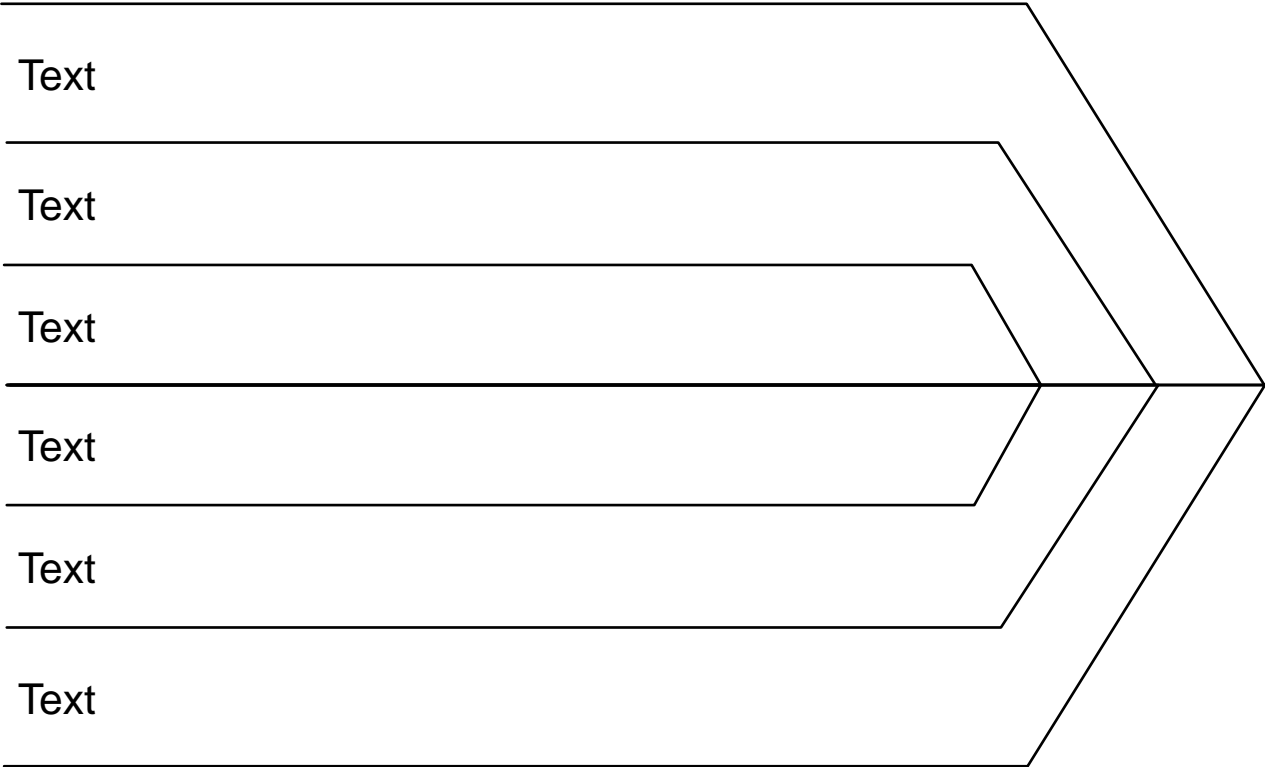

* Footnote

LINEAR N

Unit of measure

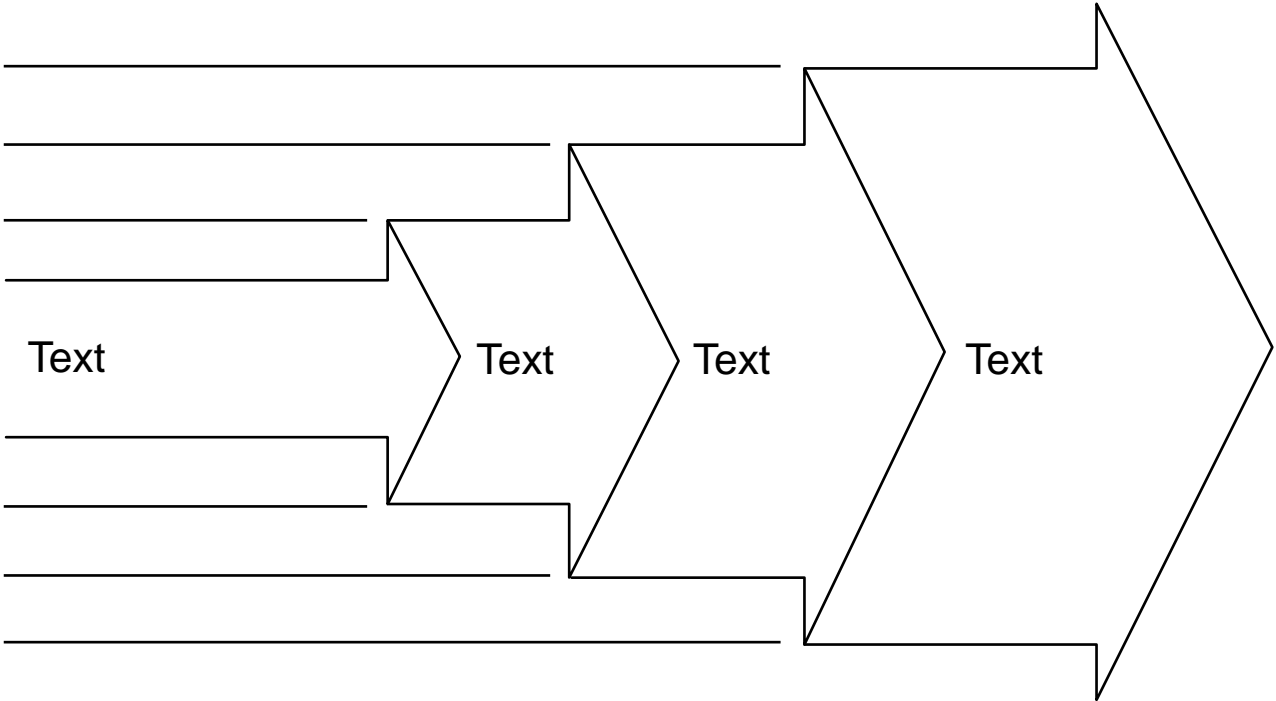

* Footnote

LINEAR P

Unit of measure

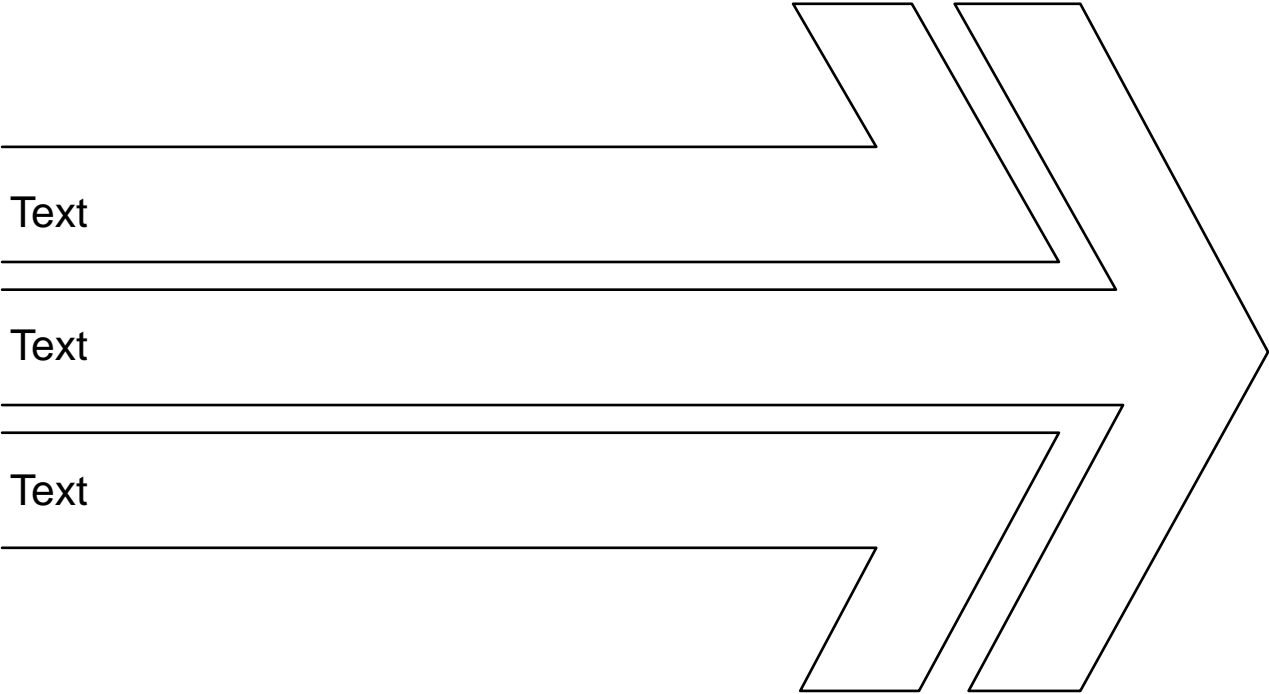

* Footnote

LINEAR Q

Unit of measure

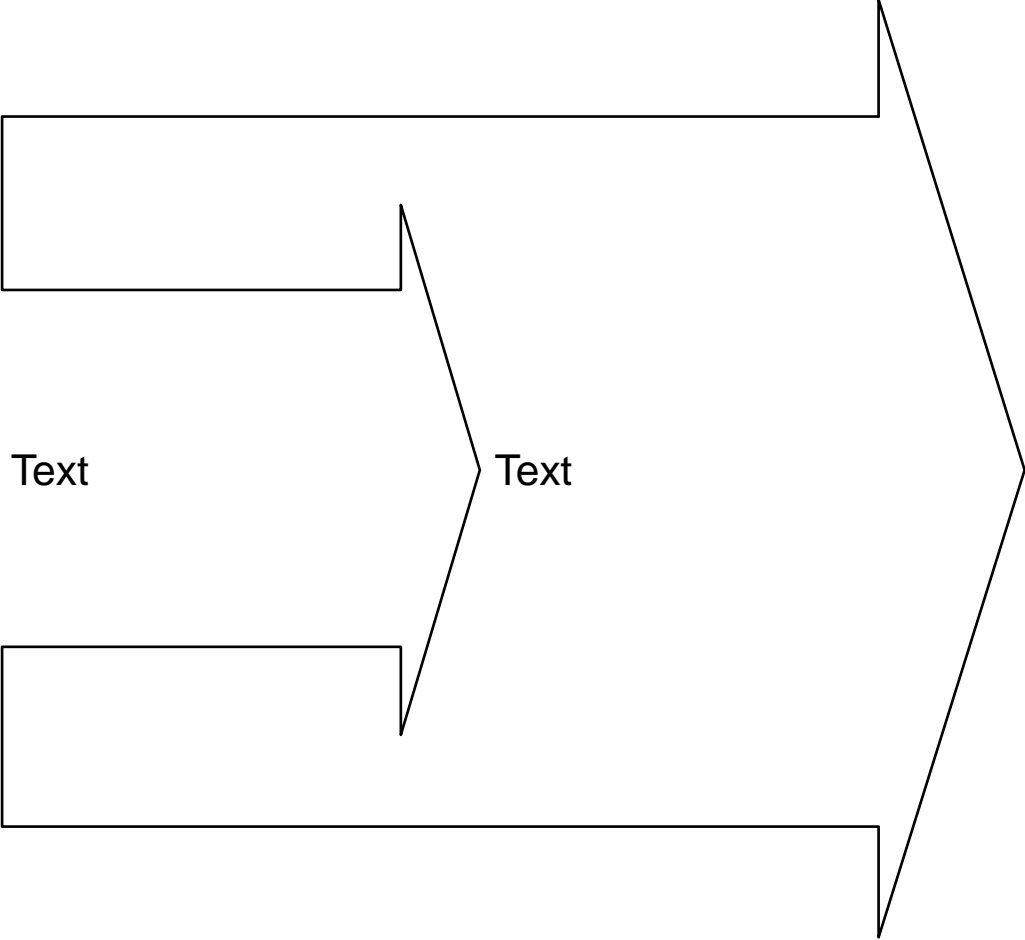

* Footnote

PROPELLER

Unit of measure

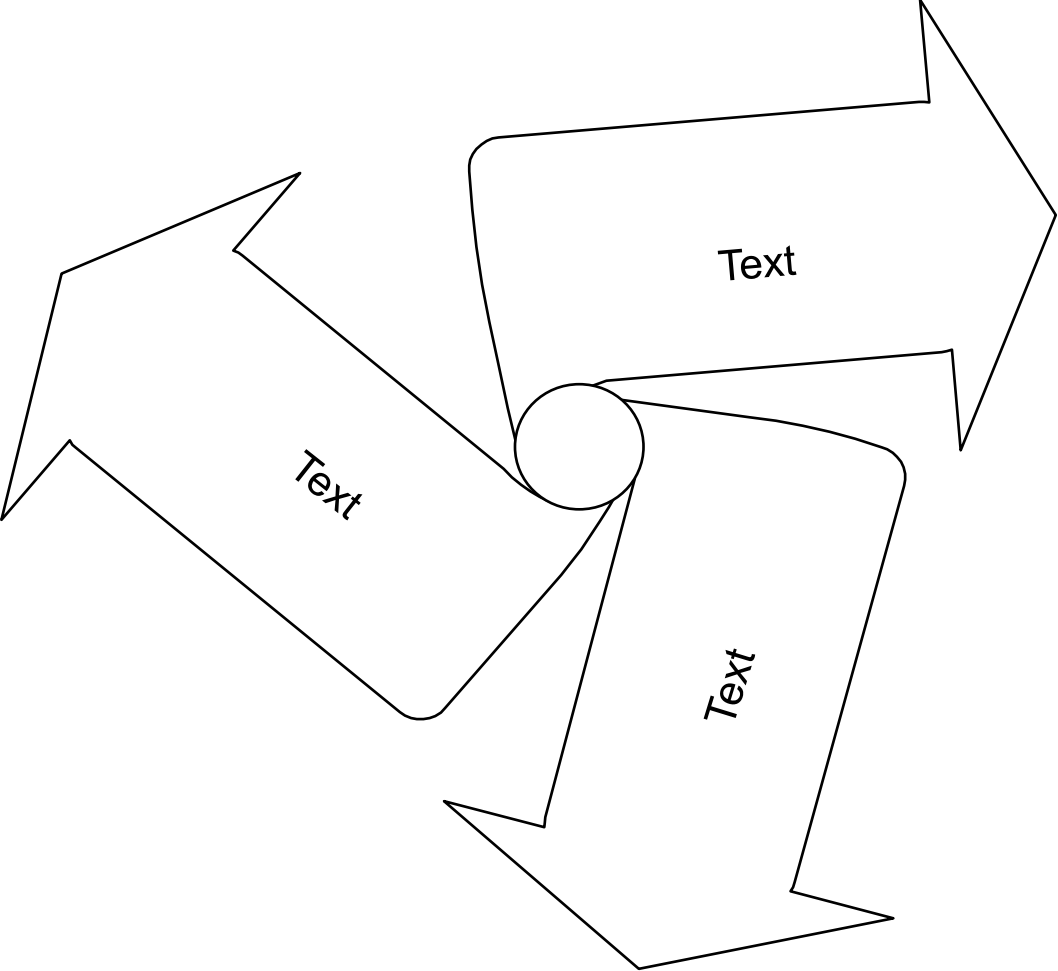

* Footnote

STEP 5

Unit of measure

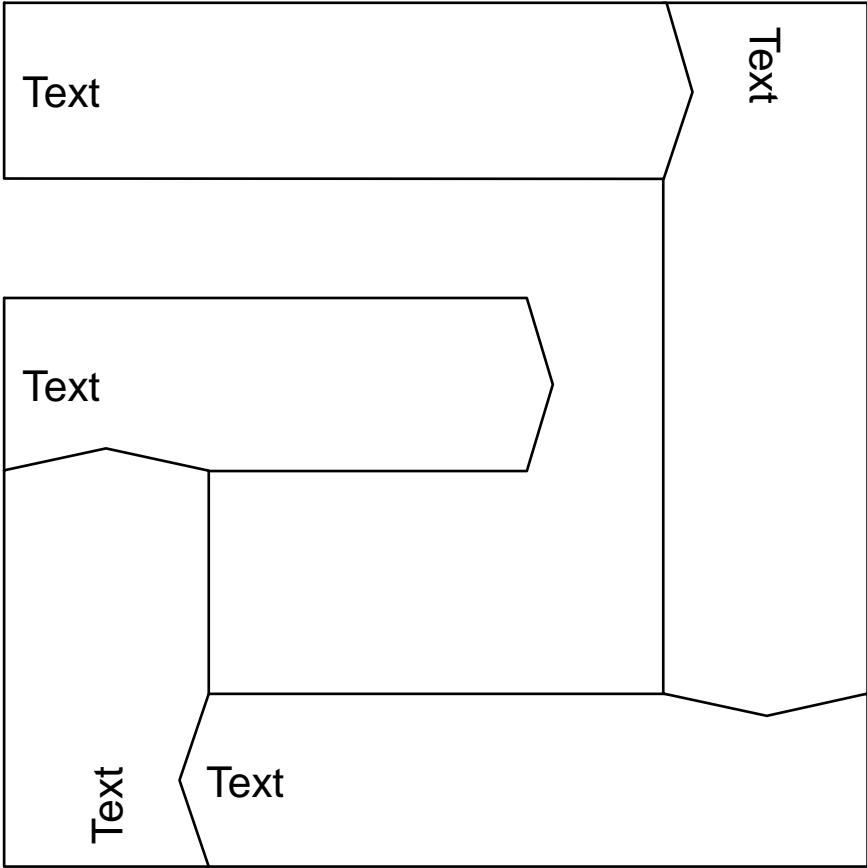

* Footnote

2 ON 1

Unit of measure

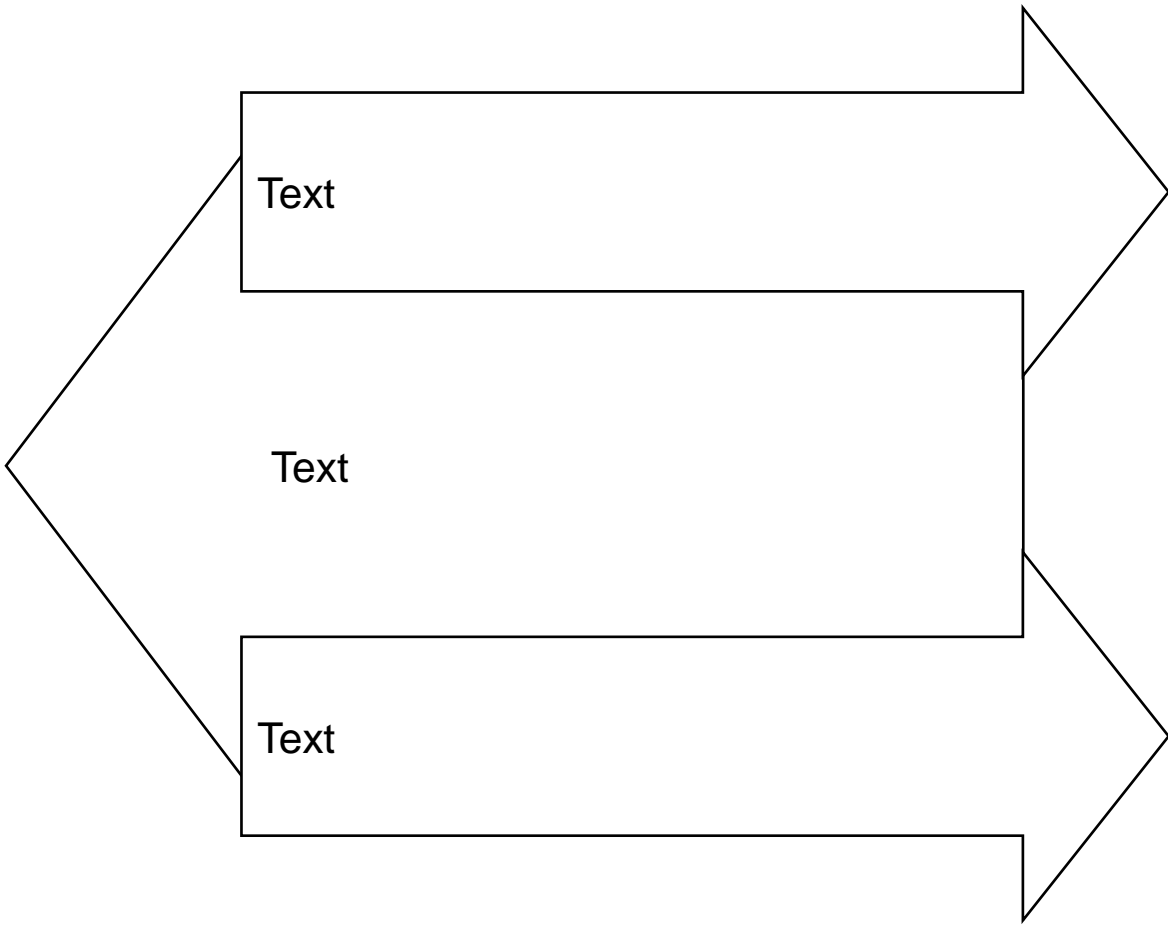

* Footnote

AGAINST

Unit of measure

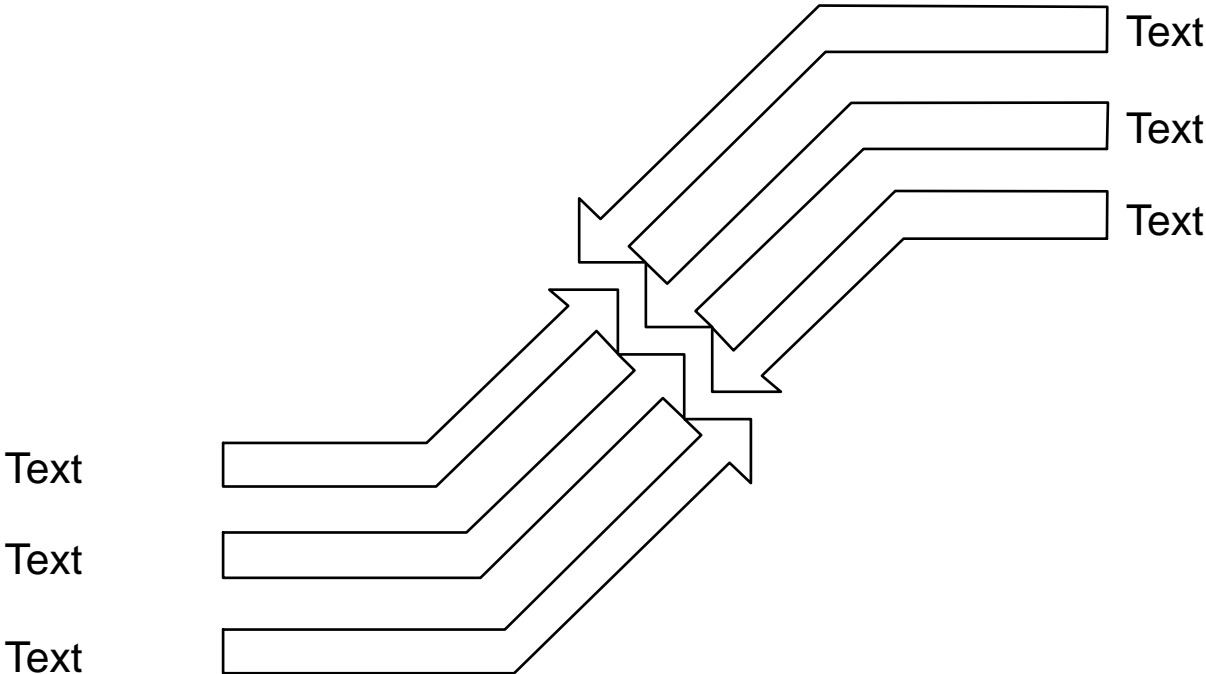

* Footnote

AT WORK

Unit of measure

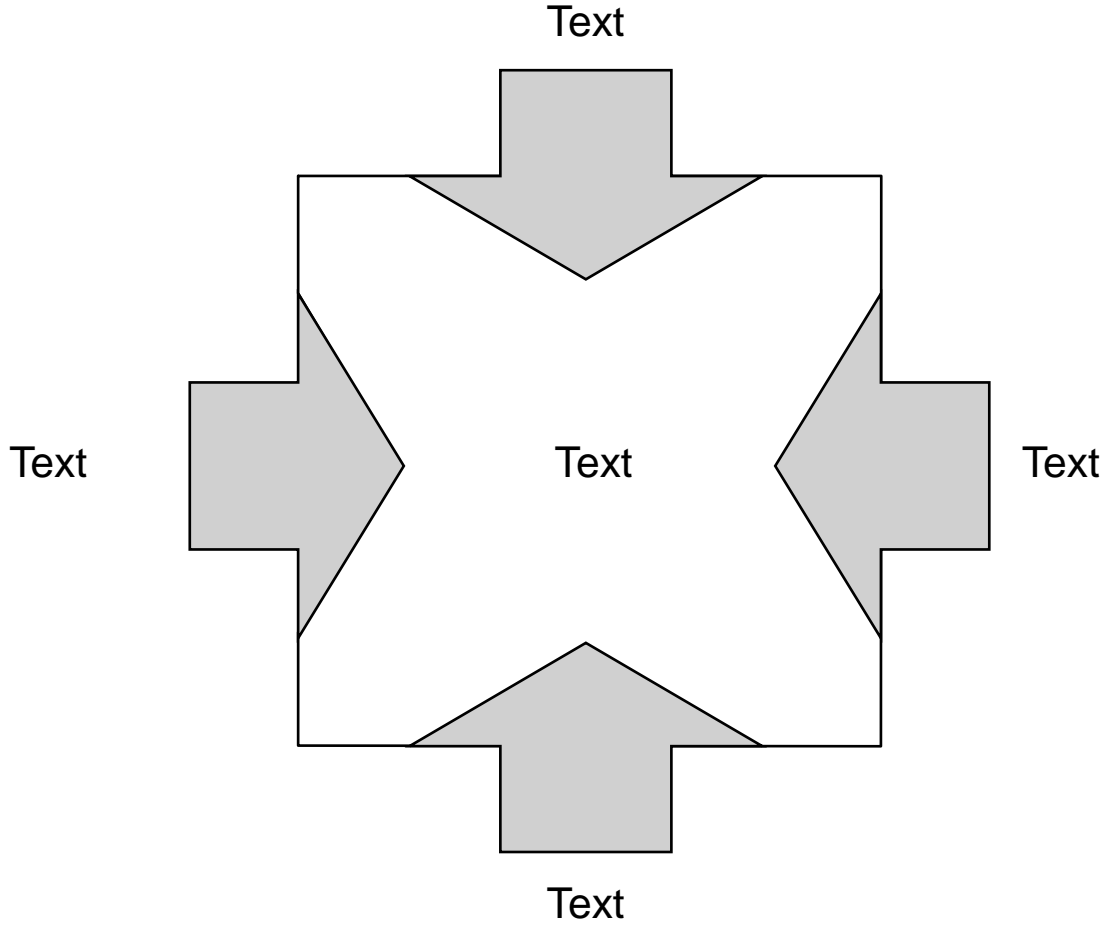

* Footnote

COUPLED HORIZ

Unit of measure

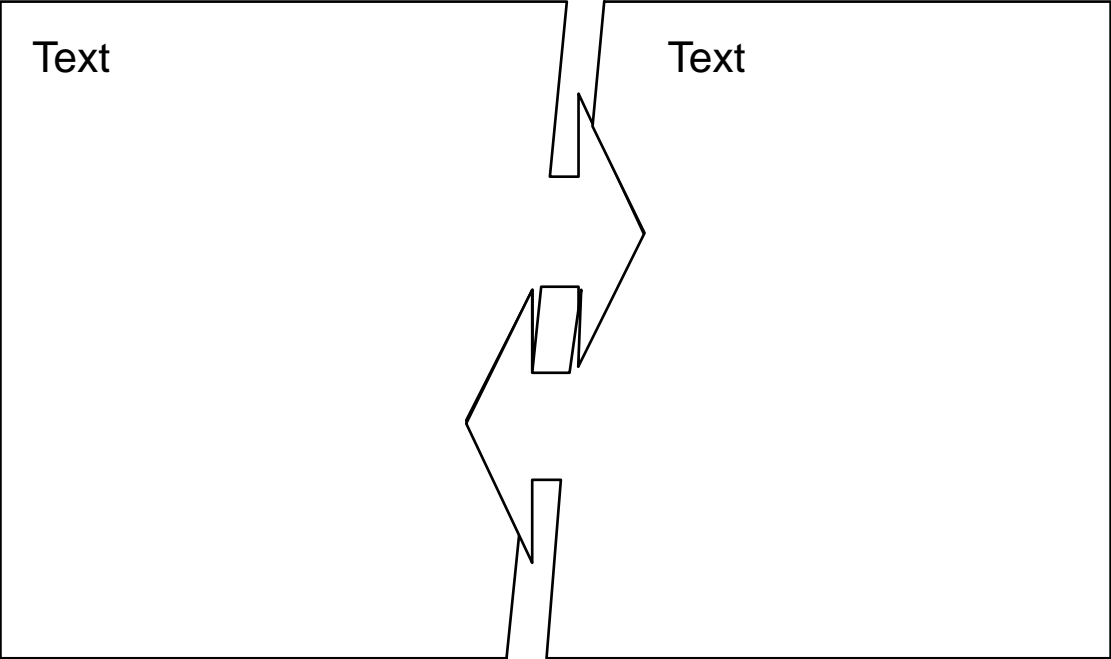

* Footnote

COUPLED VERT

Unit of measure

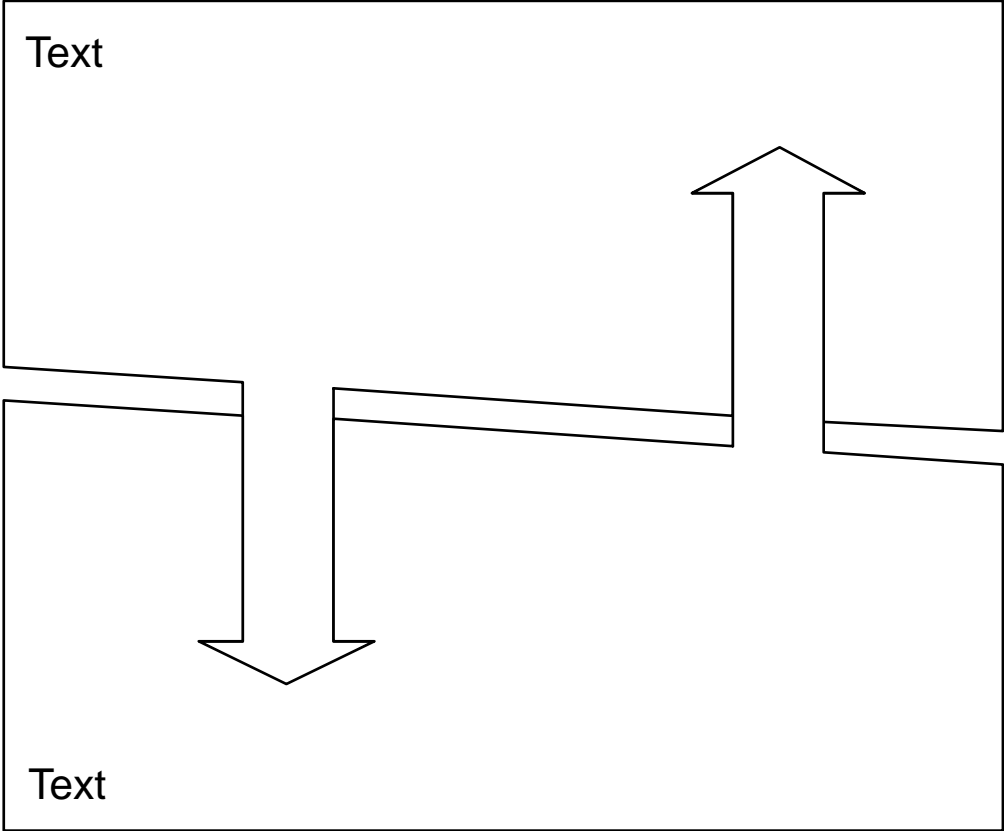

* Footnote

FOCUSED

Unit of measure

Text

Text

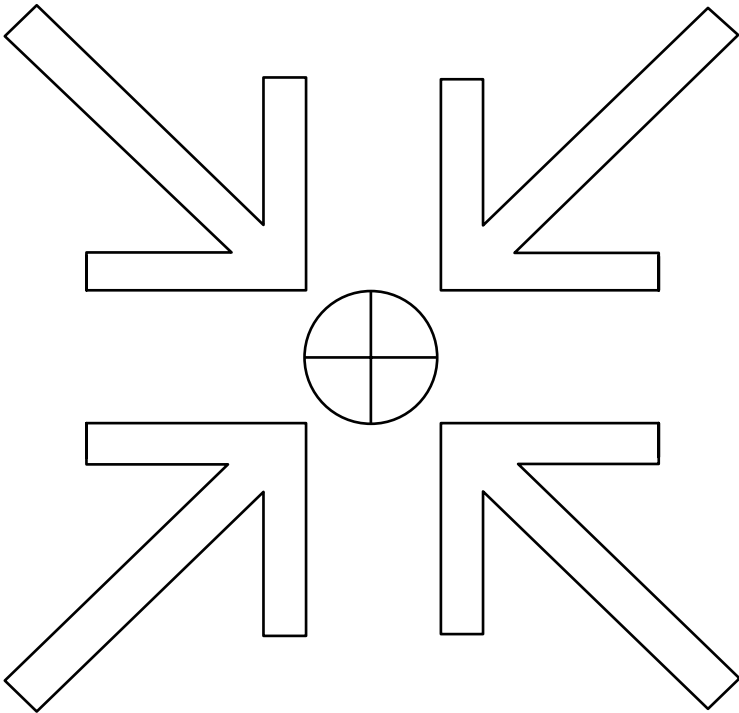

Text

Text

* Footnote

FORCES AT WORK

Unit of measure

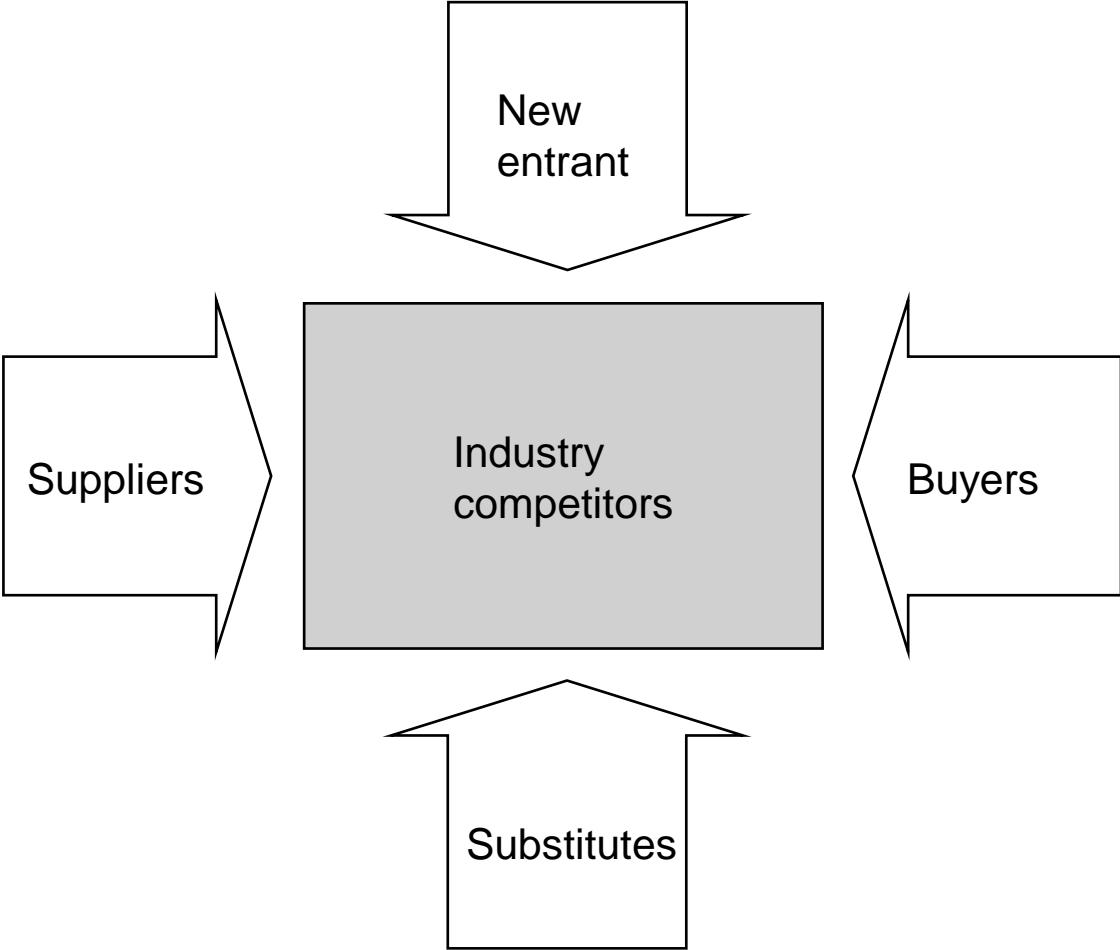

* Footnote

PARALLEL

Unit of measure

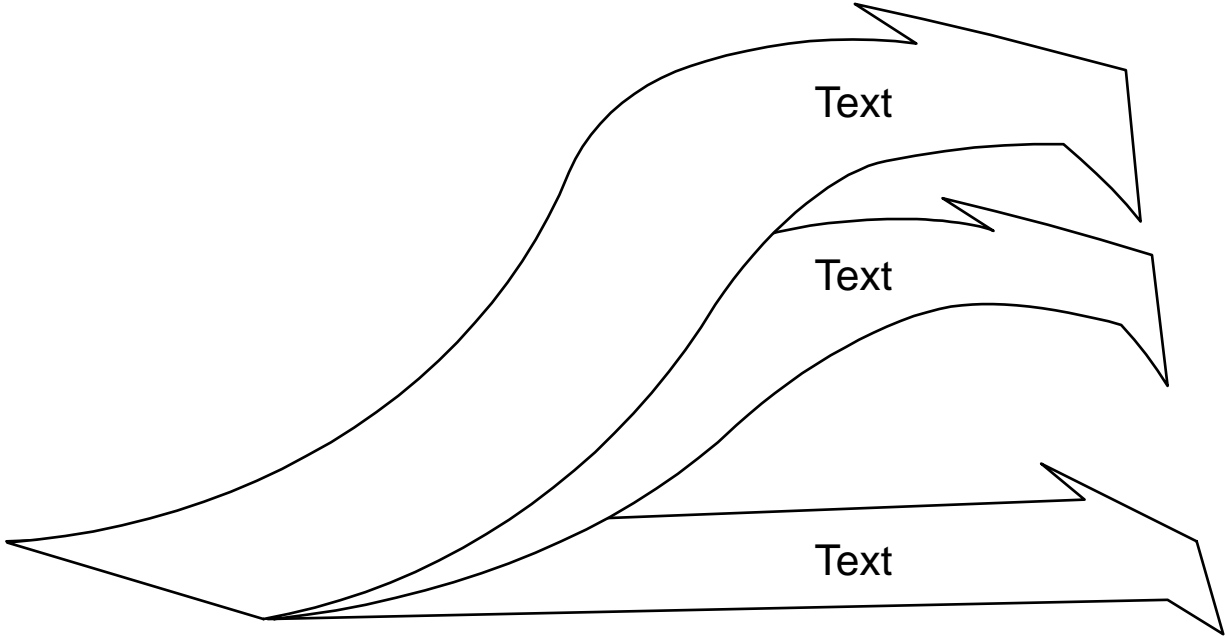

* Footnote

SPLIT

Unit of measure

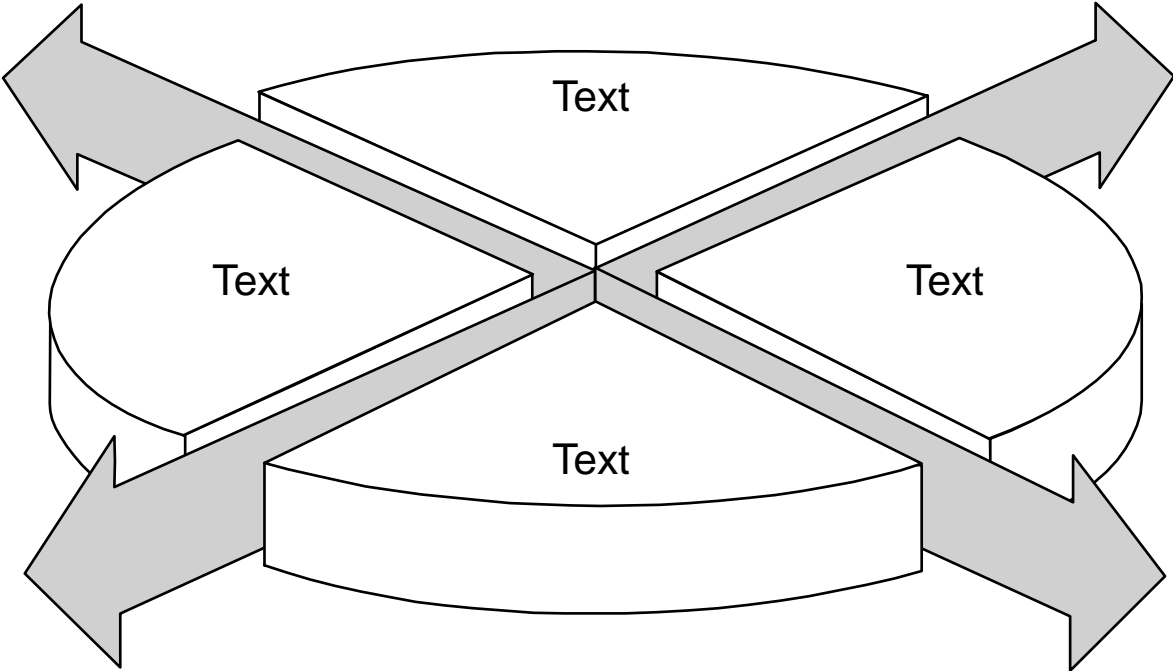

* Footnote

SURROUND

Unit of measure

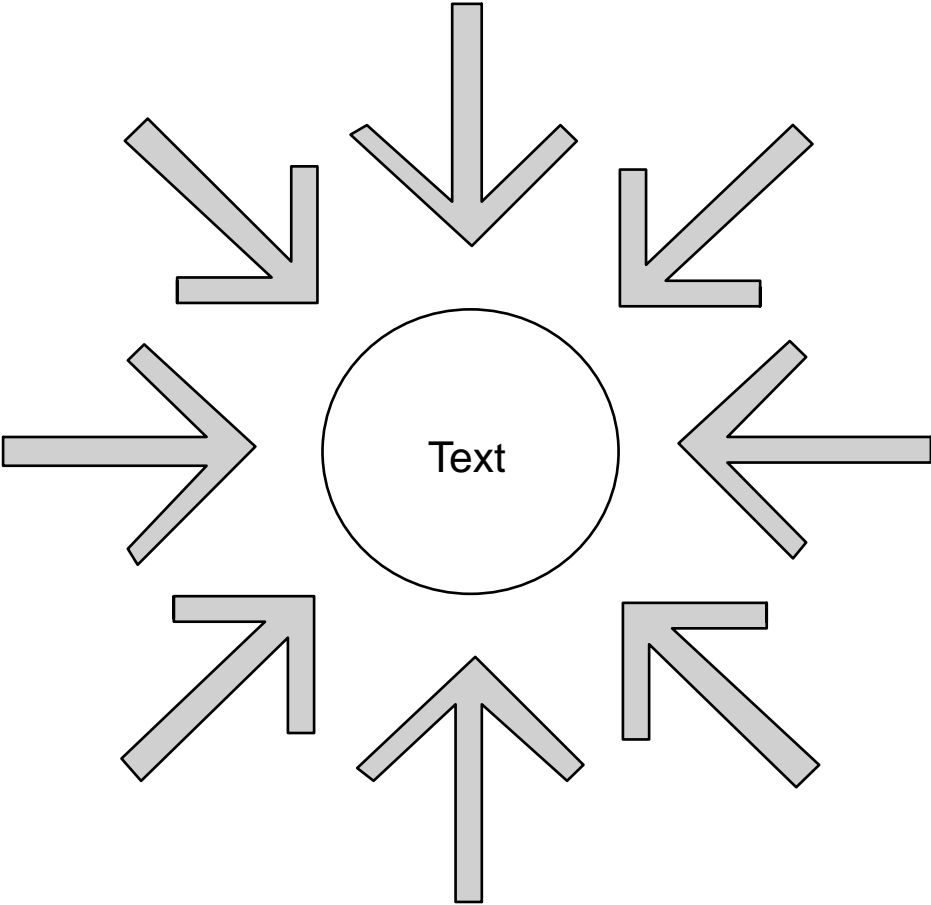

* Footnote

TWISTED

Unit of measure

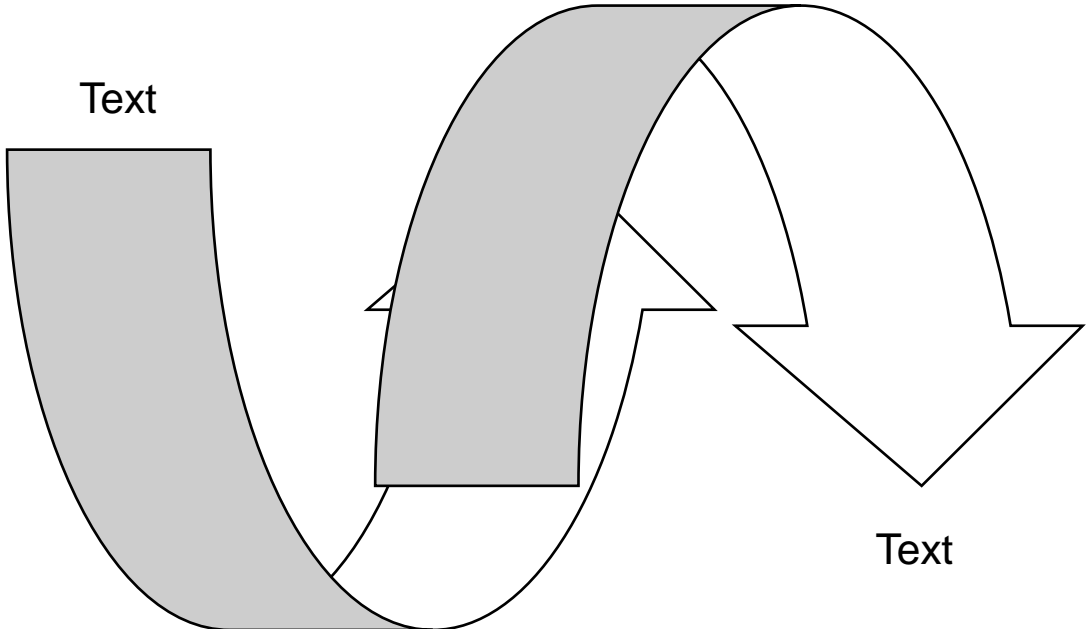

* Footnote
Source: Source

UP & AWAY

Unit of measure

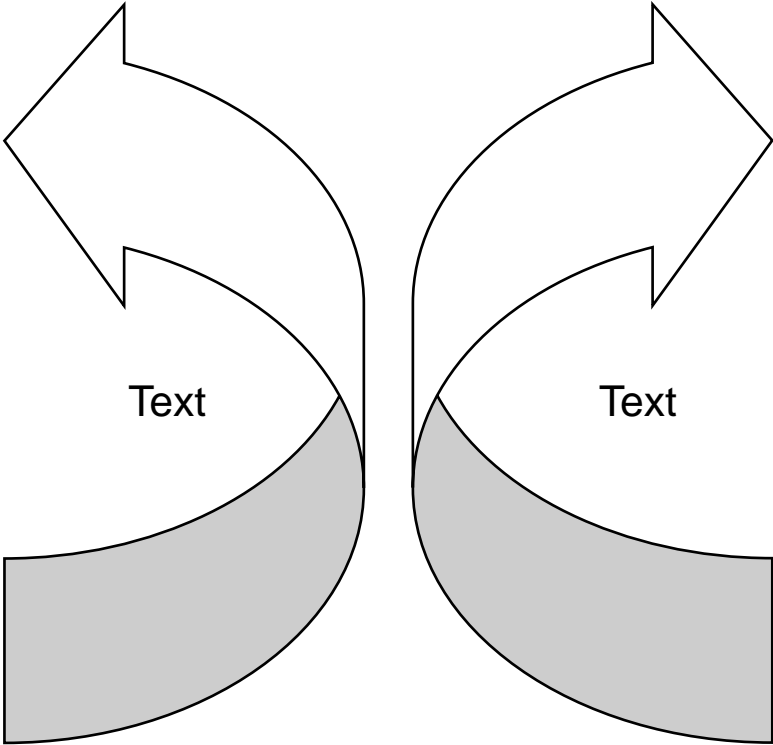

* Footnote

UP & DOWN

Unit of measure

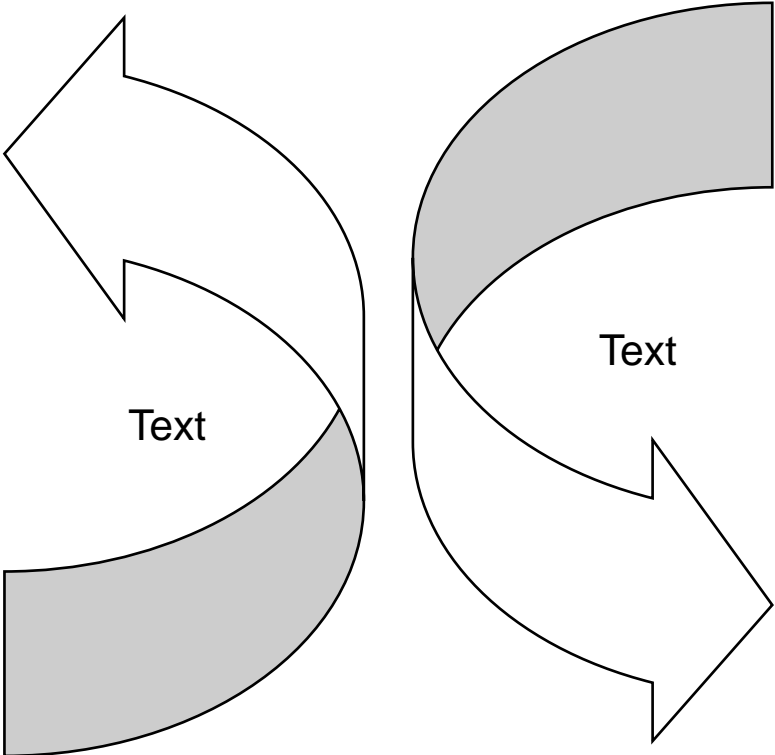

* Footnote

2S-5S

Unit of measure

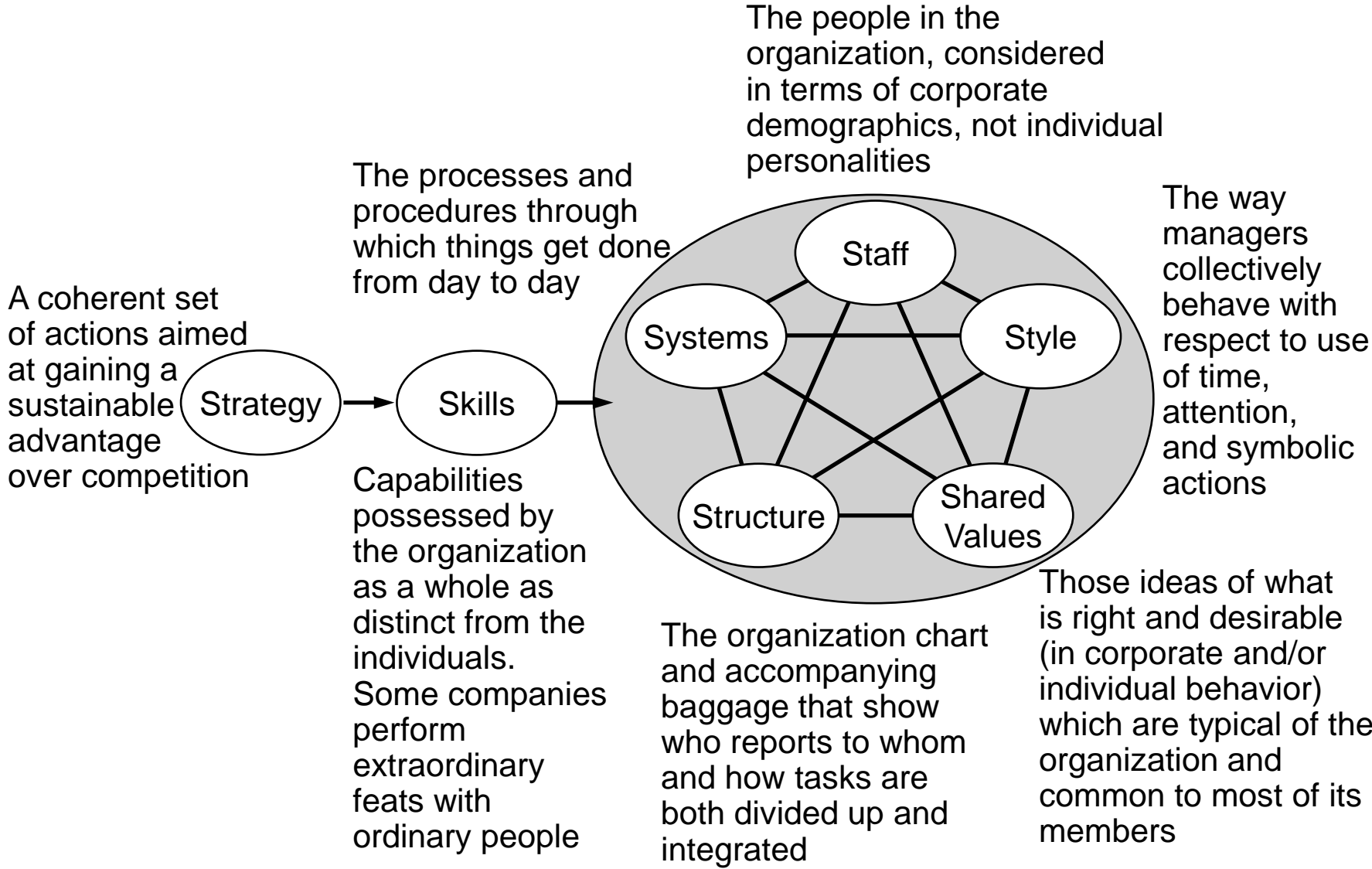

* Footnote

3CS TRIANGLE

Unit of measure

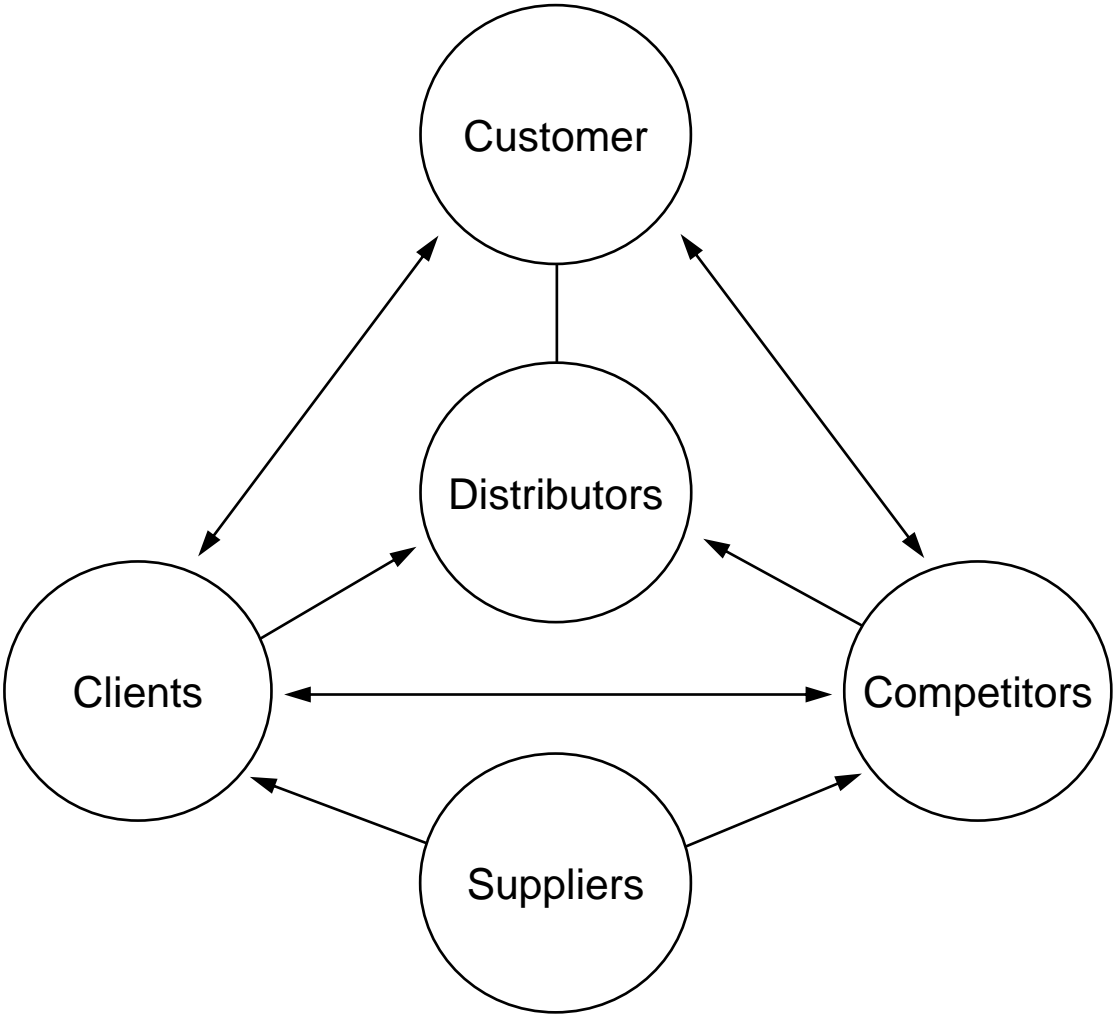

* Footnote

3S-4S

Unit of measure

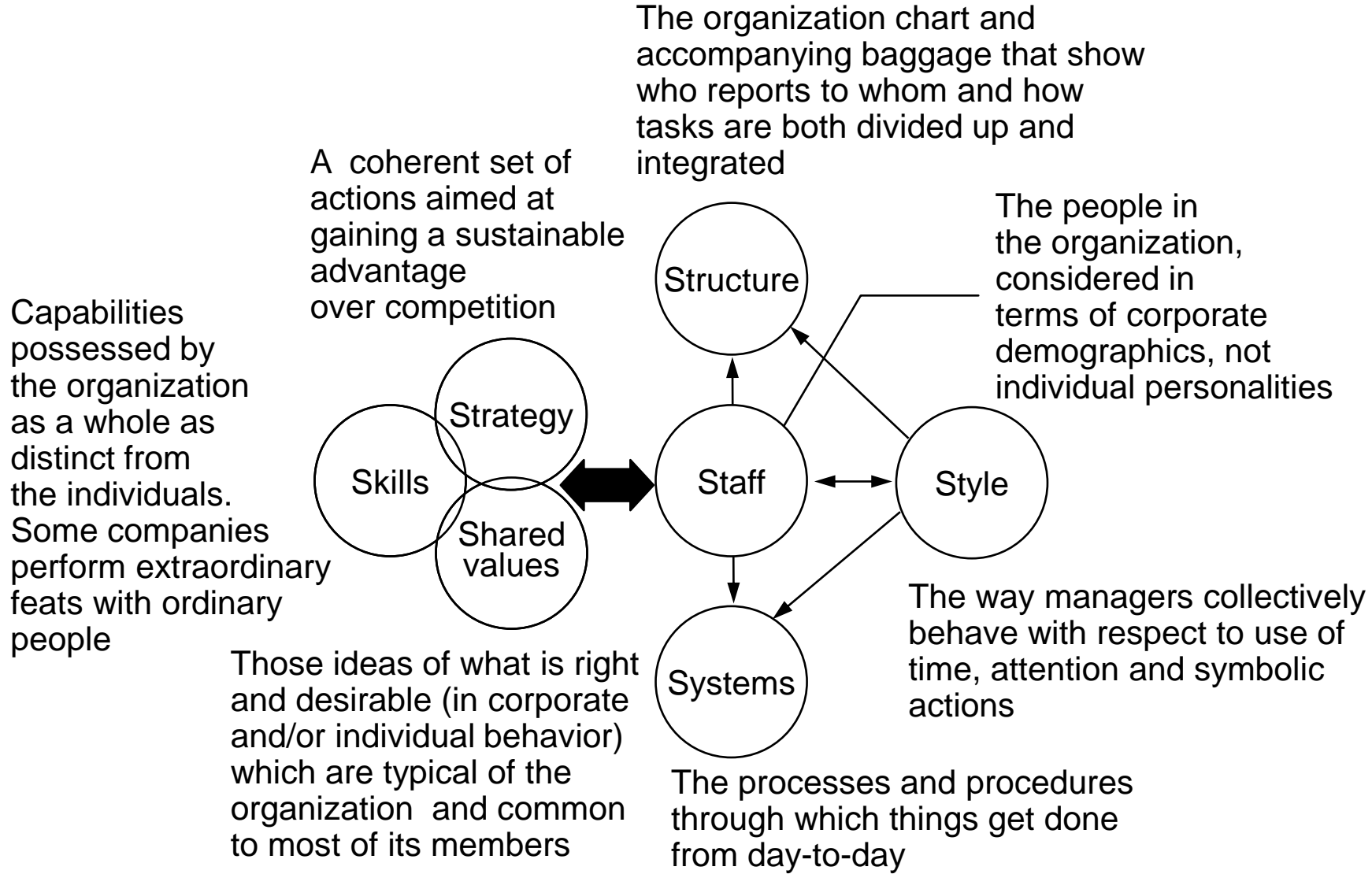

* Footnote

7S

Unit of measure

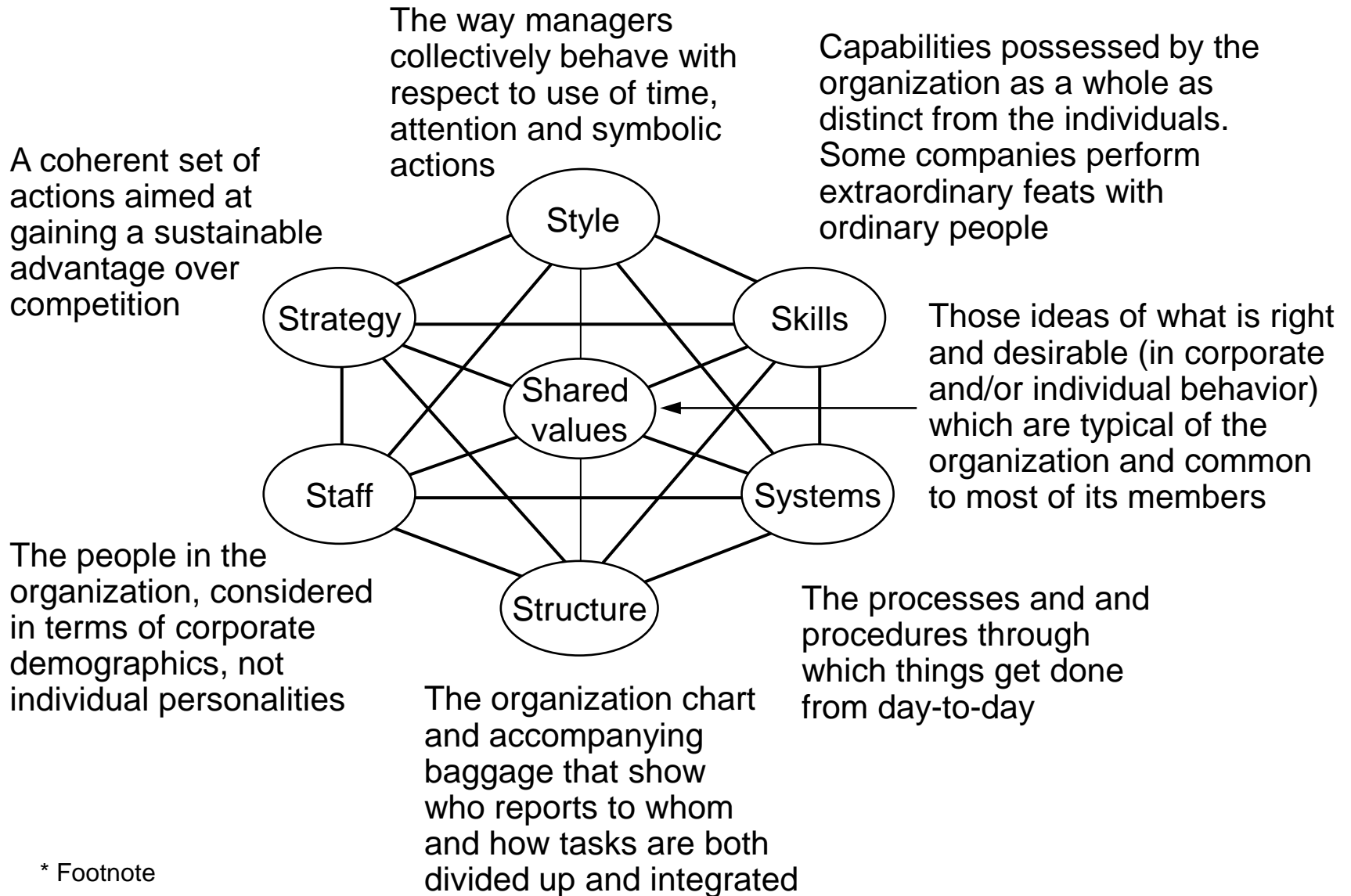

* Footnote

BUSS PORTFOLIO

Unit of measure

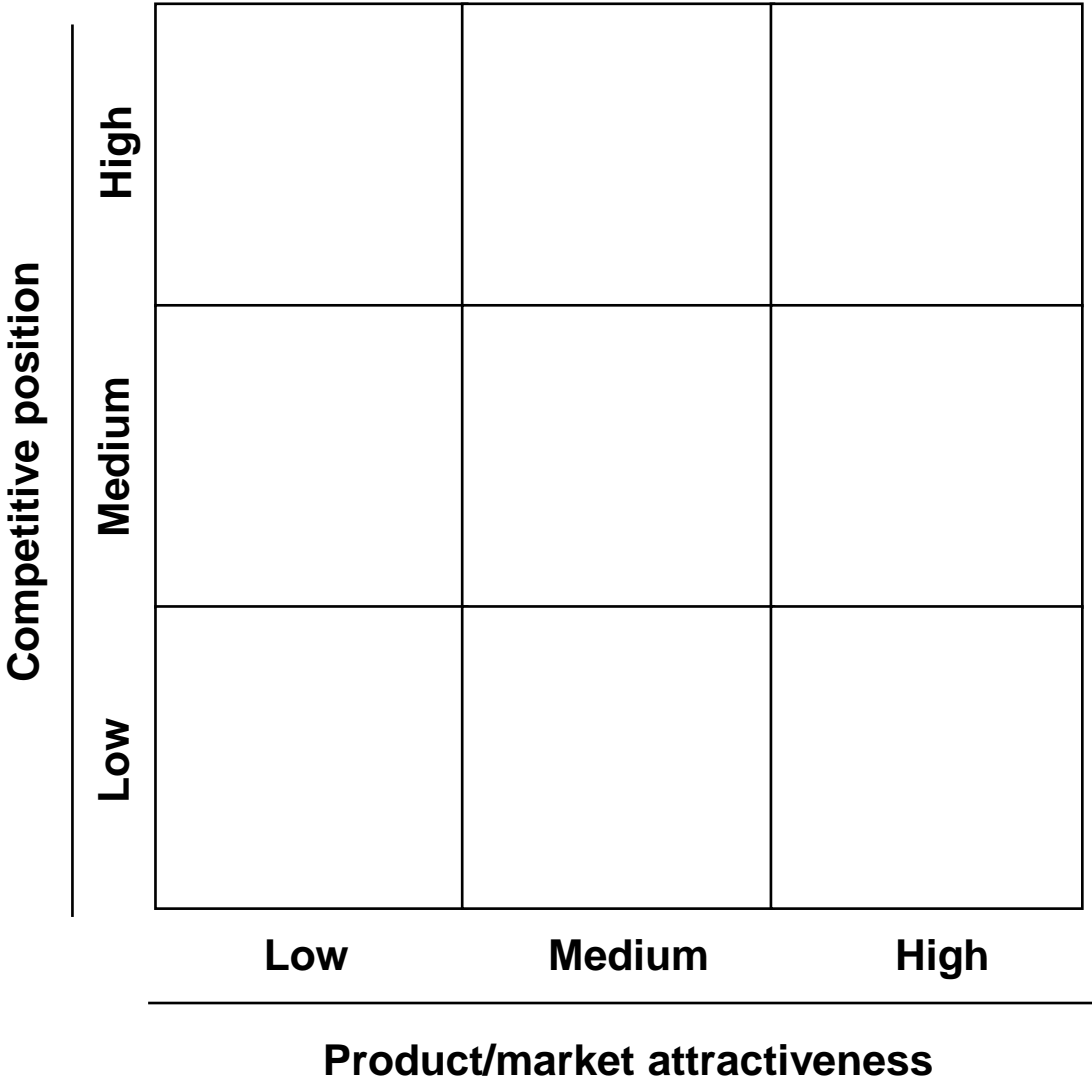

* Footnote

CHANGE BOARD

Unit of measure

Change vision	Commitment		Capability	
	Conviction	Courage	Individual activity	Enabling devices
Chief Executive				
Leadership groups				
Down the line				
External constitution				

* Footnote

DELTA P

Unit of measure

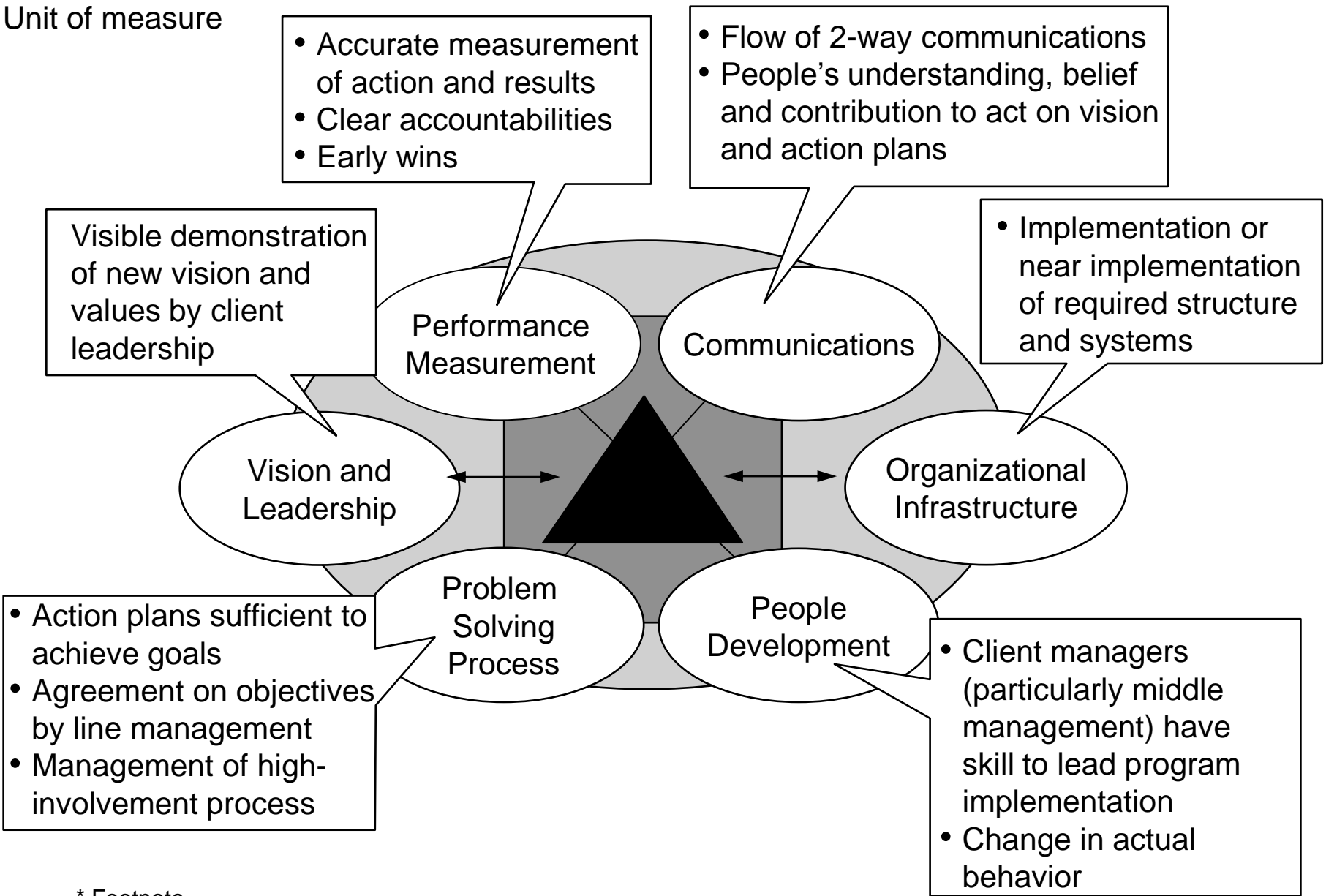

* Footnote

MACS

Unit of measure

- Industry attractiveness
- Competitive position
- Restructuring/rationalization opportunities

Value-creation potential in business unit

- Corporate center skills
- Business unit linkages
- Taxation/valuation differences

Relative ability to extract value

	High	Medium	Low
Natural owner	Retain and give top priority	Retain and give priority	Retain and manage for code or liquidate
"One of the pack"	Probably divest	Divest	Divest or liquidate

* Footnote

MANUFACTURING STRATEGY

Unit of measure

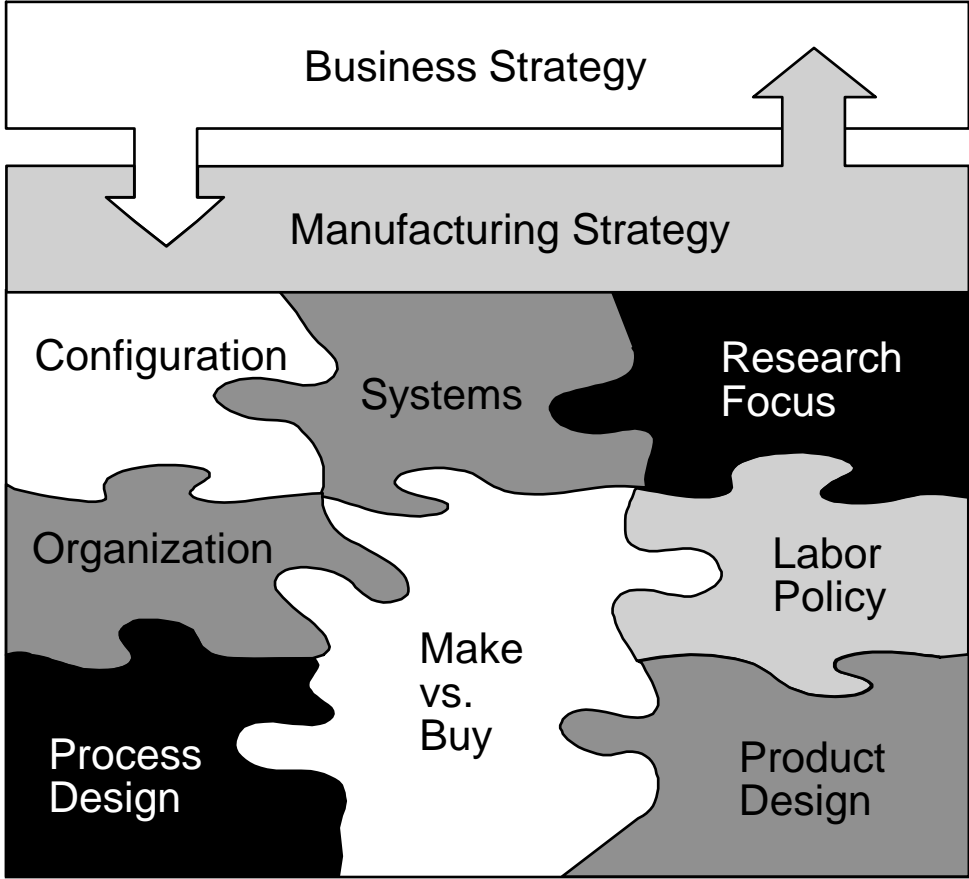

* Footnote

PENTAGON

Unit of measure

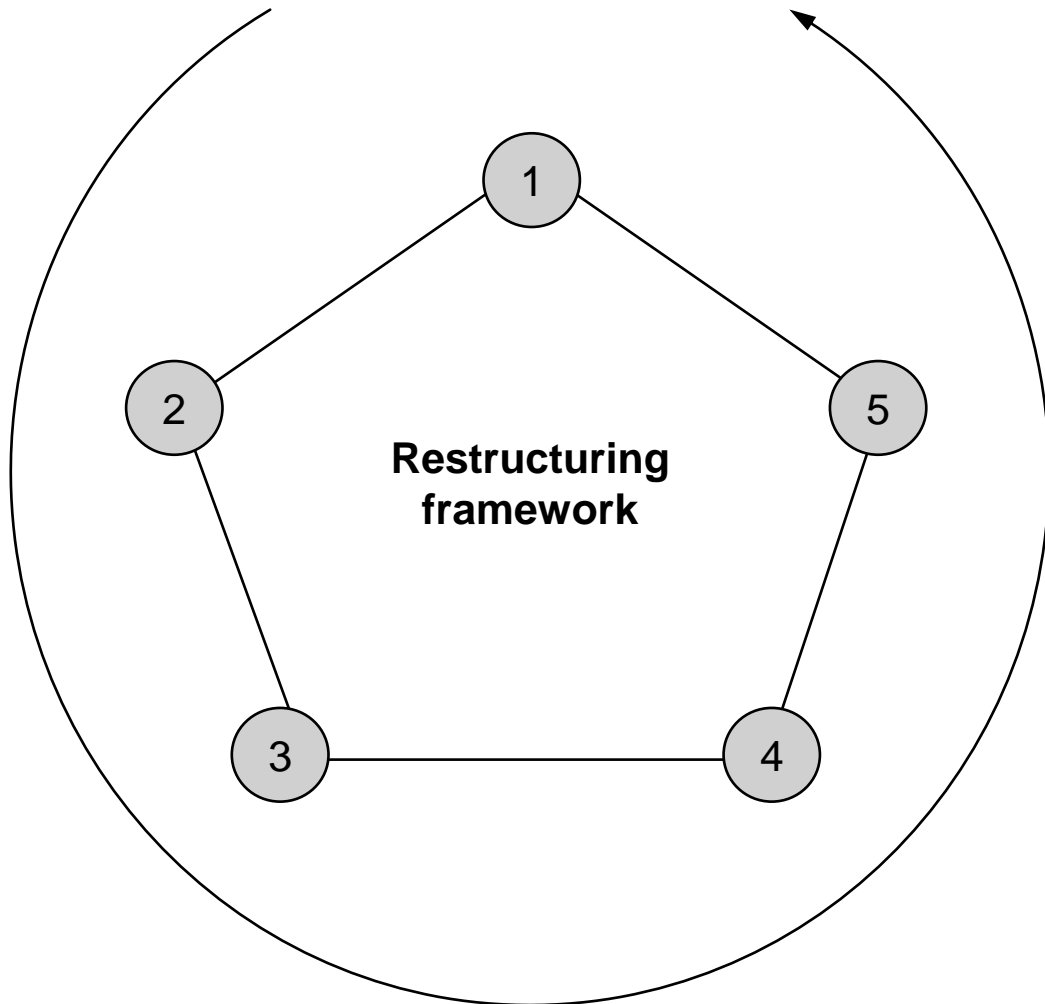

* Footnote
Source: Source

PRICE BENEFIT

Unit of measure

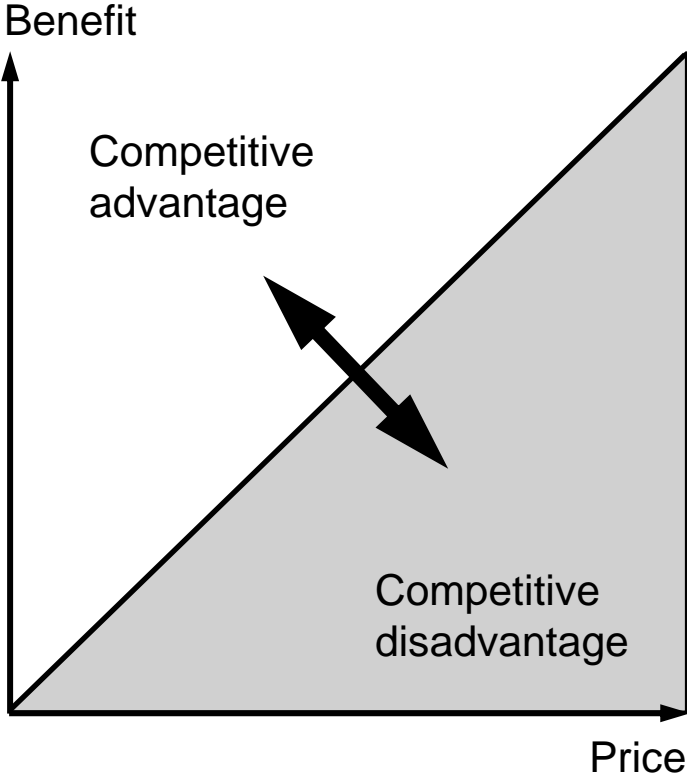

* Footnote

SMILE CHART

Unit of measure

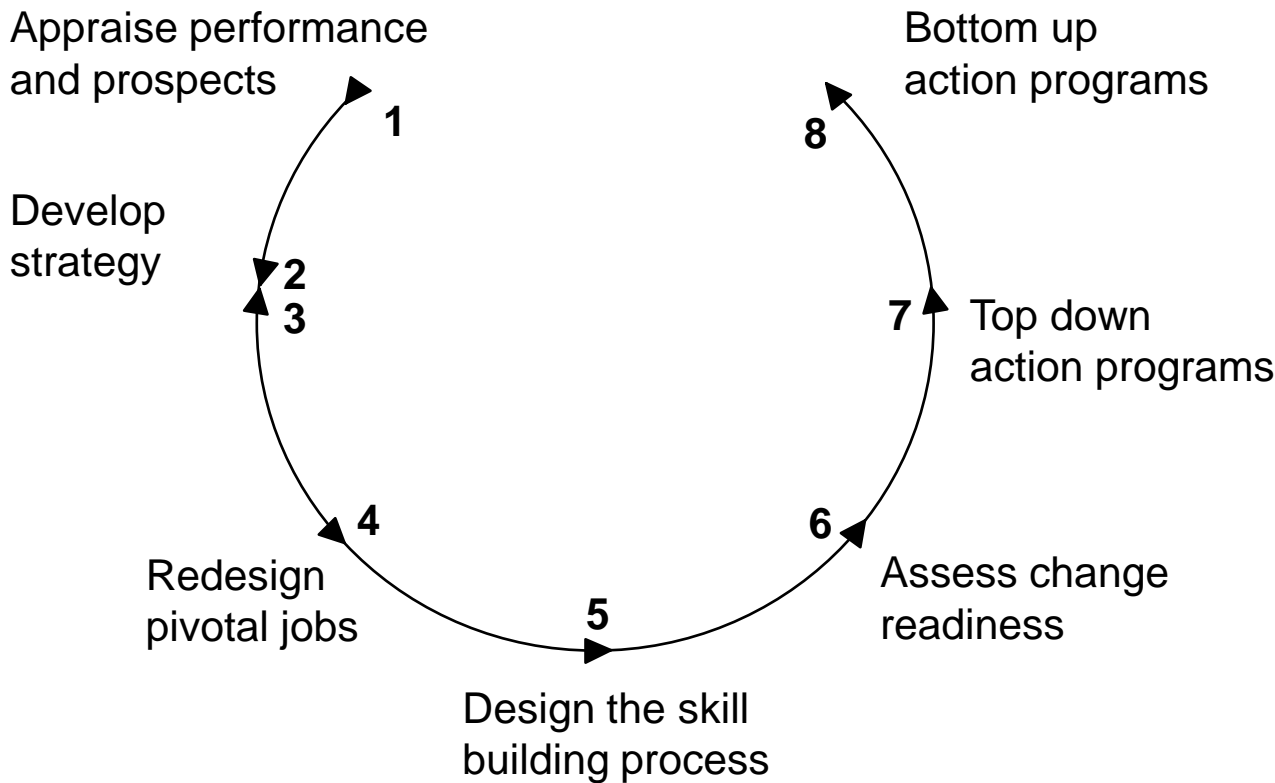

* Footnote

STRAT GAMEBOARD

Unit of measure

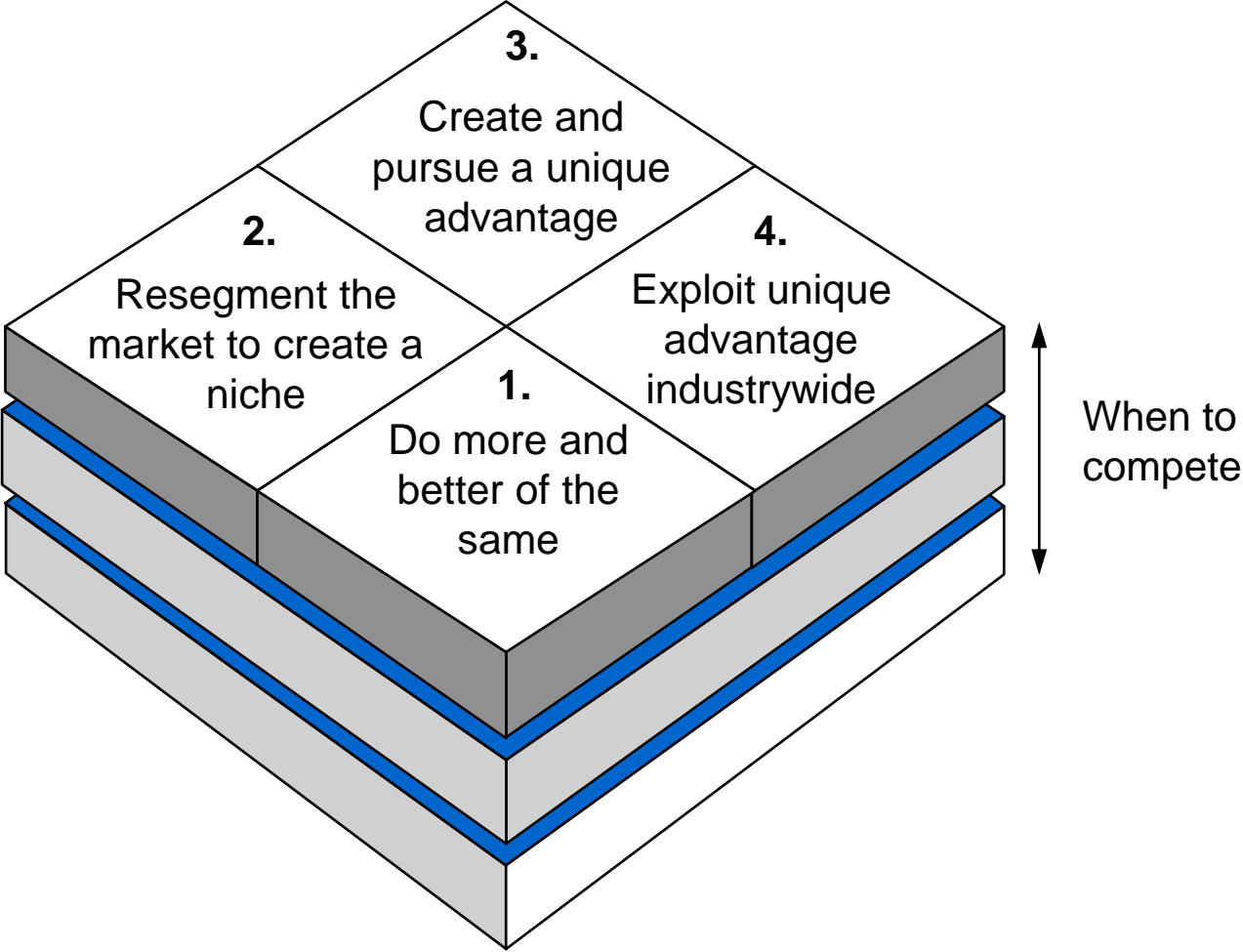

* Footnote

STRAT MANAGE

Unit of measure

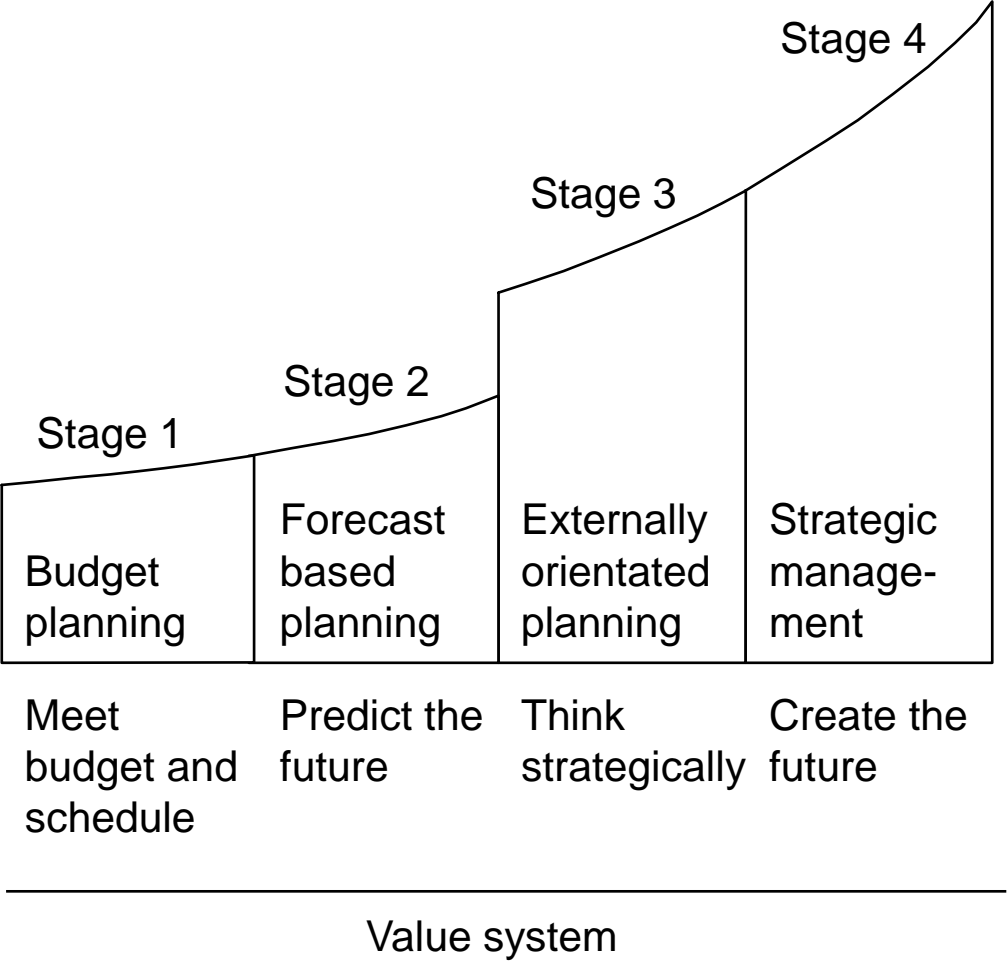

* Footnote

TREE PRODUCTIVITY

Unit of measure

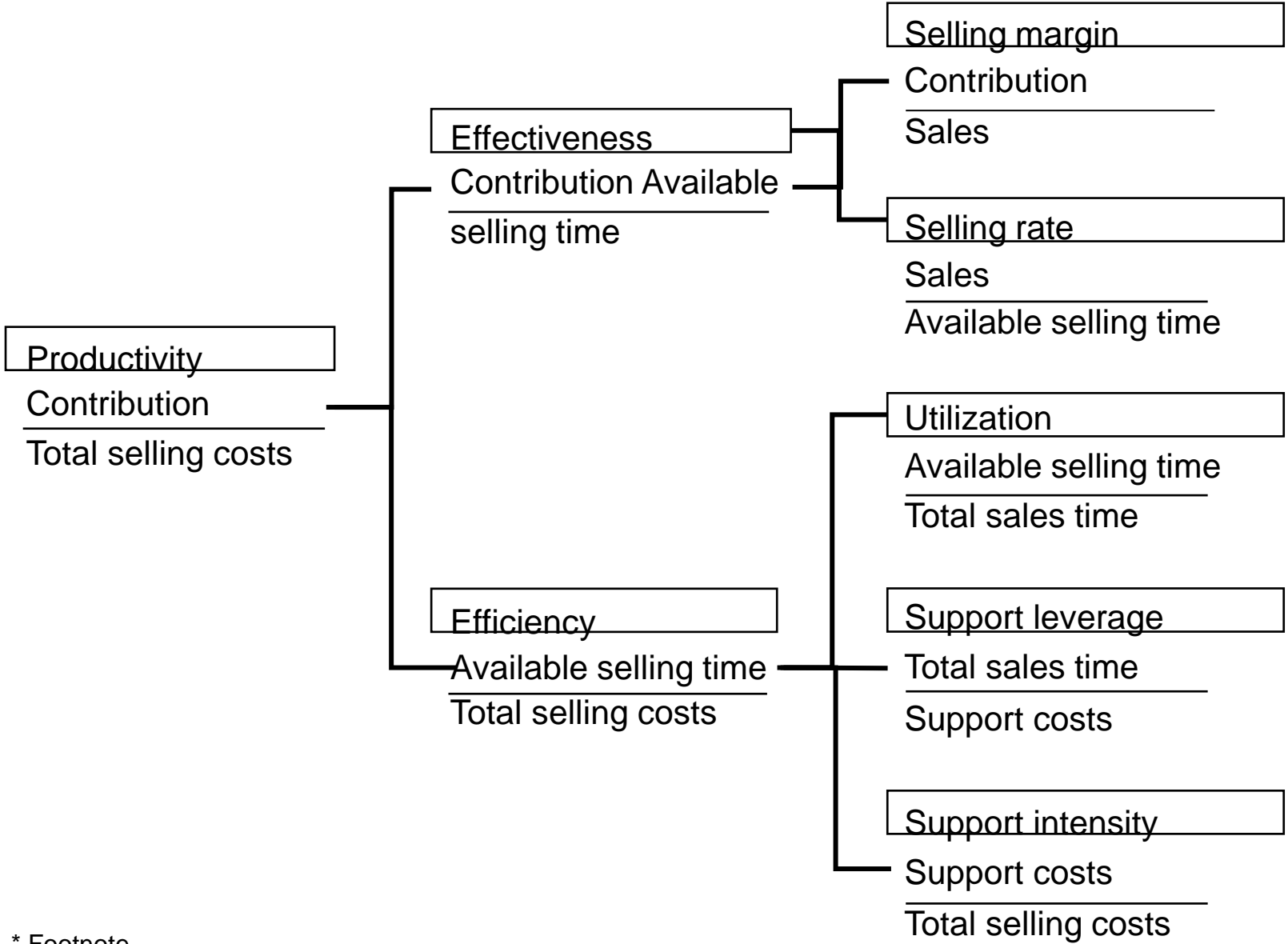

* Footnote

VALUE CREATION

Unit of measure

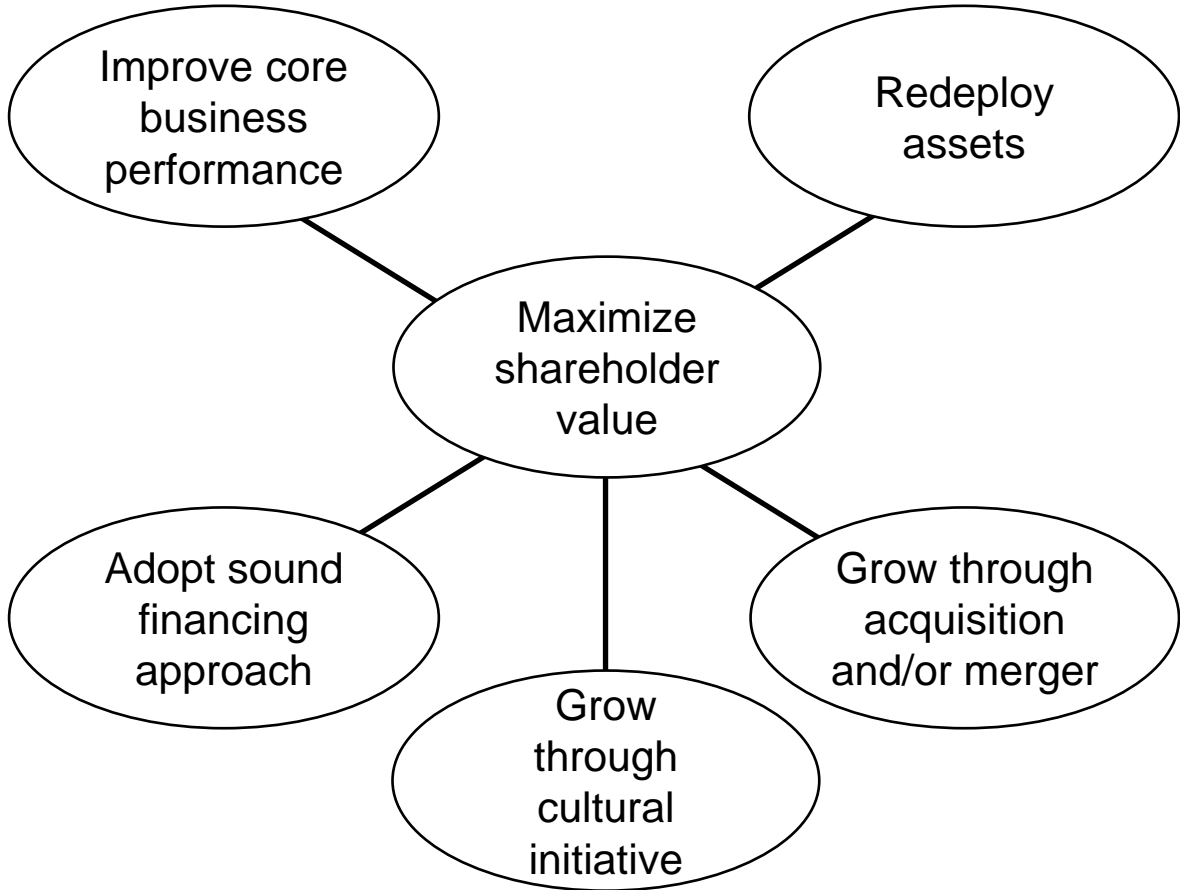

* Footnote

VALUE SOURCES

Unit of measure

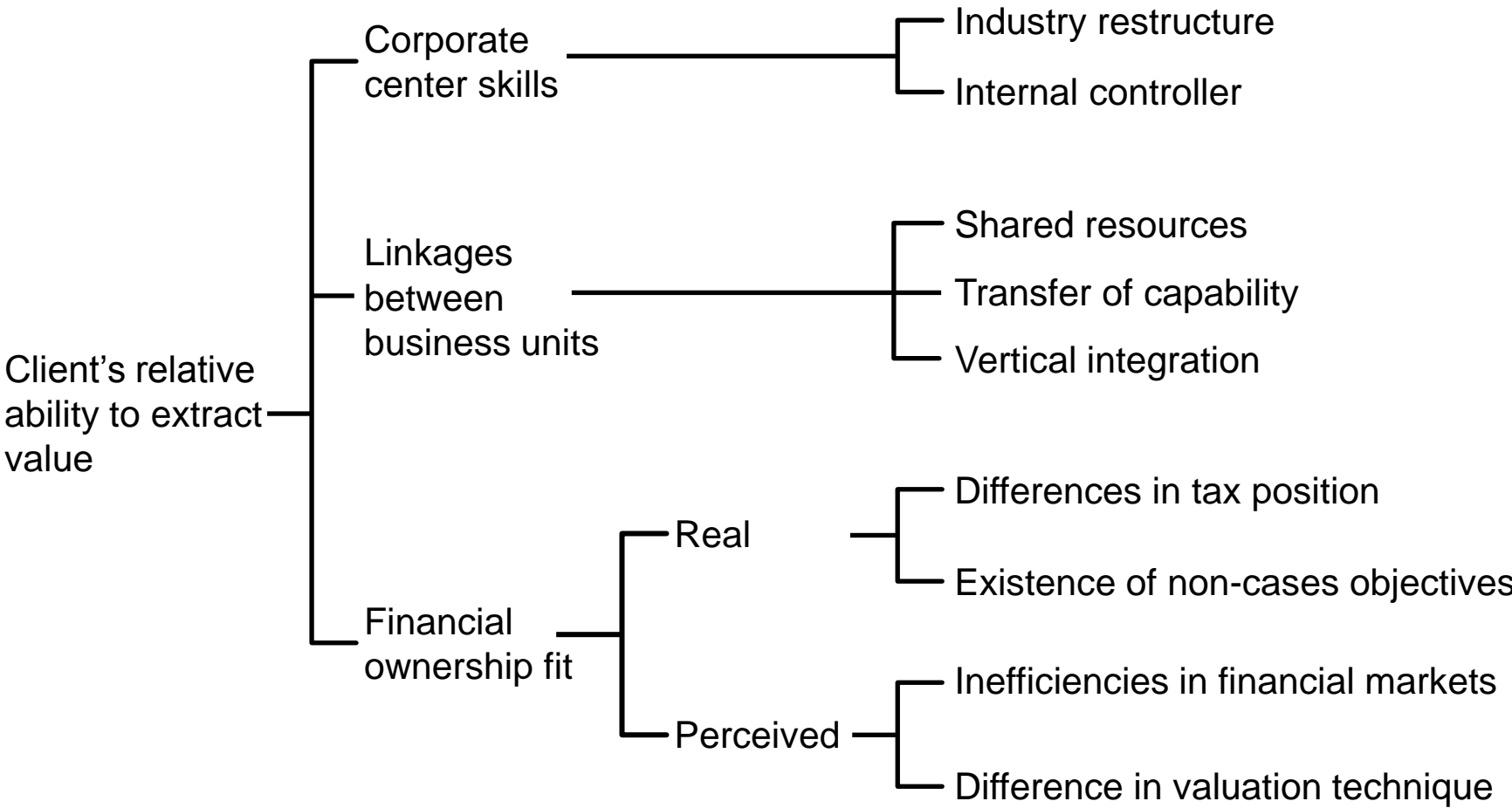

* Footnote

GANTT10

Unit of measure

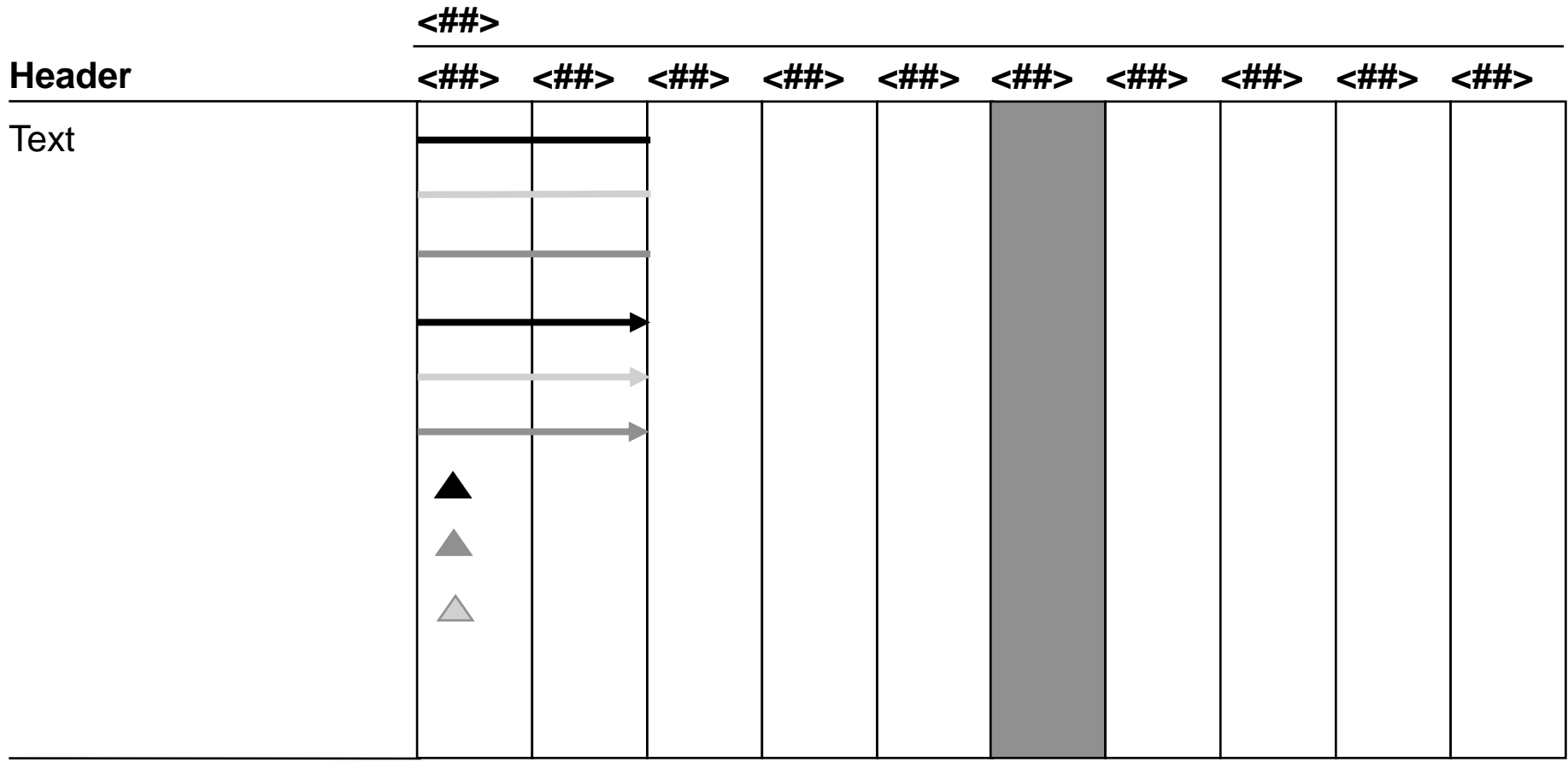

* Footnote

GANTT15

Unit of measure

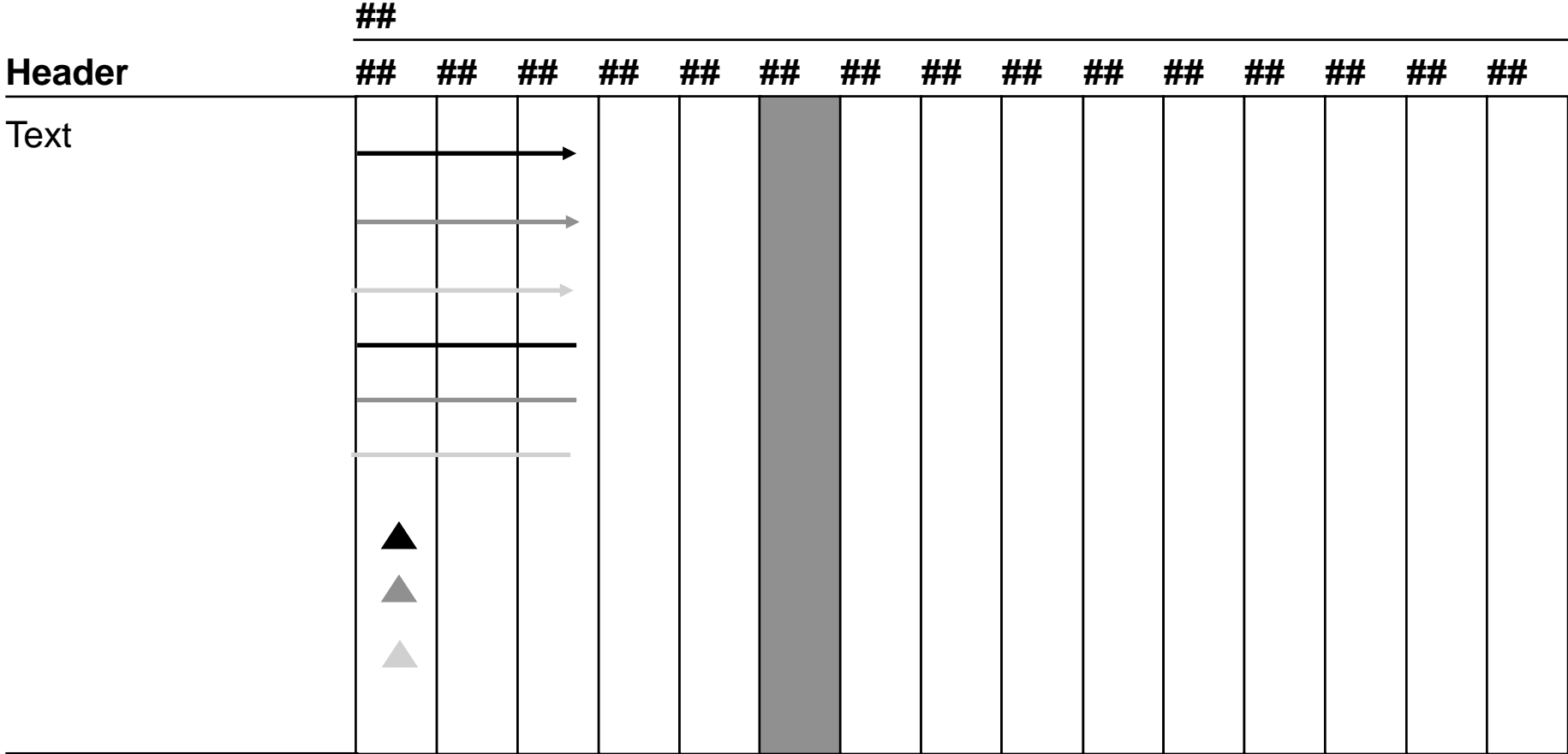

* Footnote

VENN 2

Unit of measure

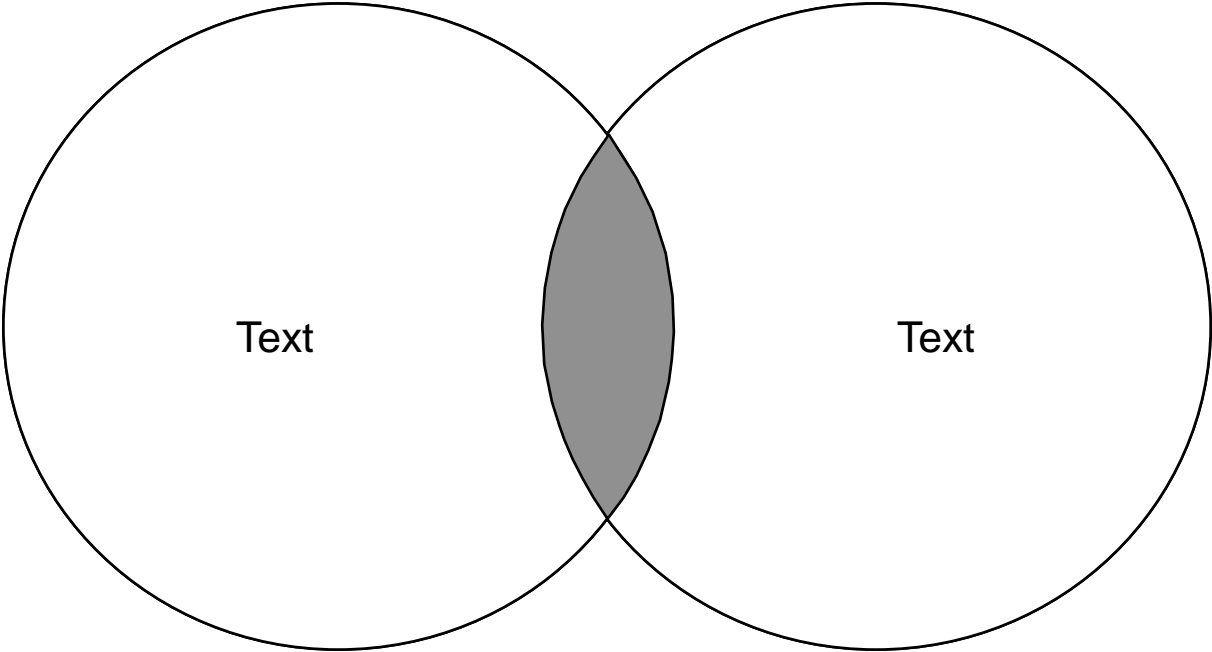

* Footnote

VENN 3

Unit of measure

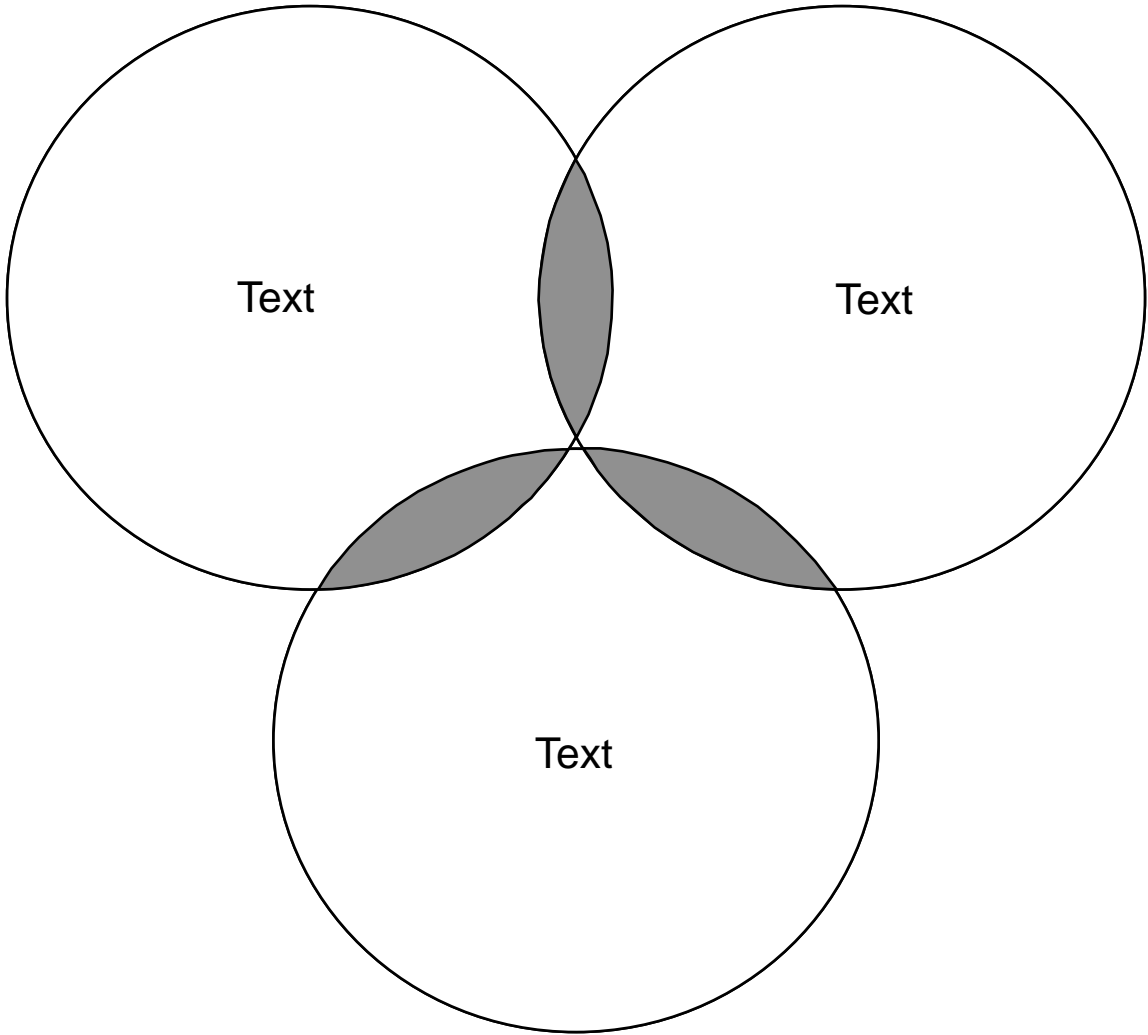

* Footnote

CONFIDENTIAL

Frequently Used Template

Data Driven

Template

June 2002

This report is solely for the use of client personnel. No part of it may be circulated, quoted, or reproduced for distribution outside the client organization without prior written approval from McKinsey & Company. This material was used by McKinsey & Company during an oral presentation; it is not a complete record of the discussion.

AREA

Unit of measure

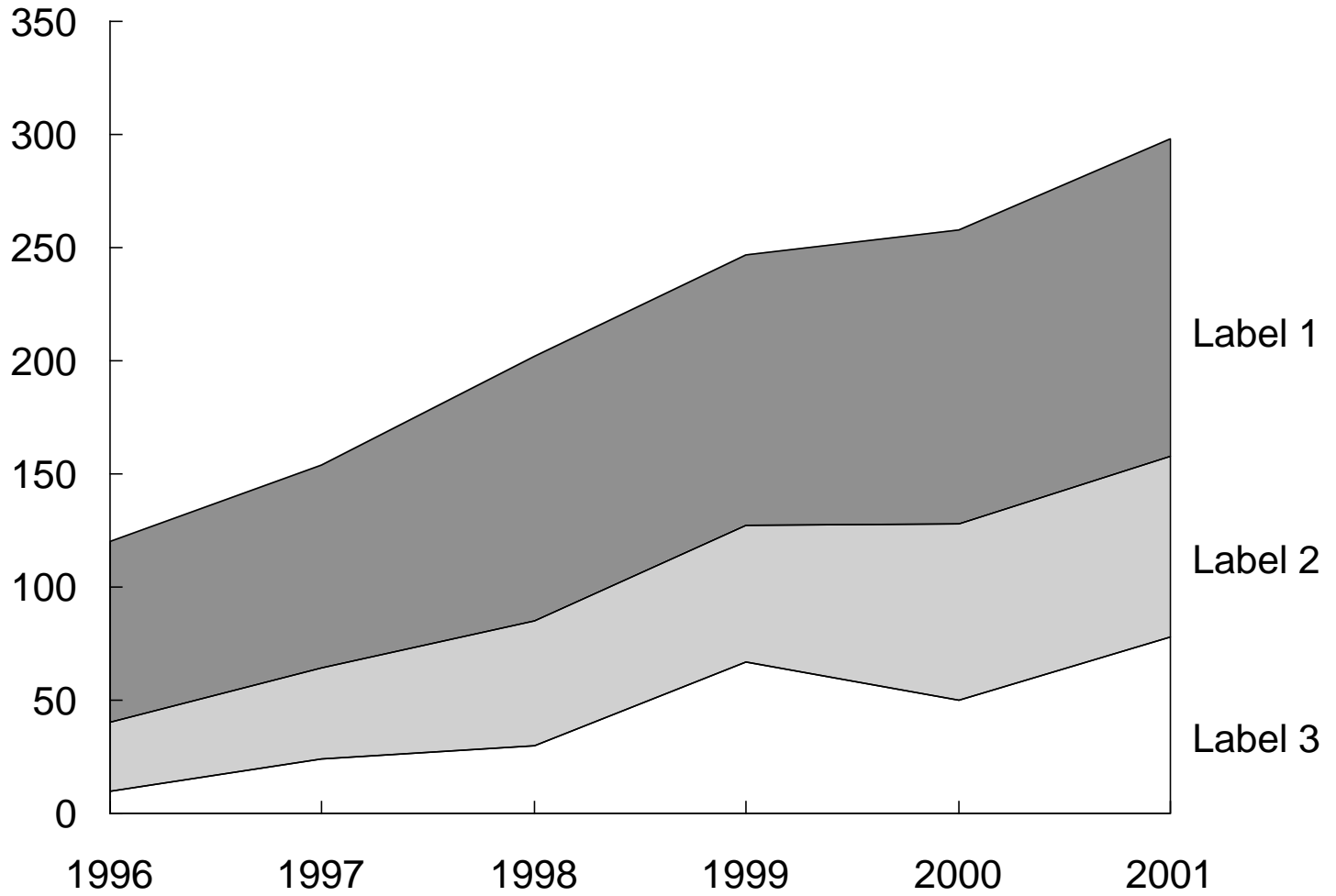

* Footnote

Source: Source

BAR

Unit of measure

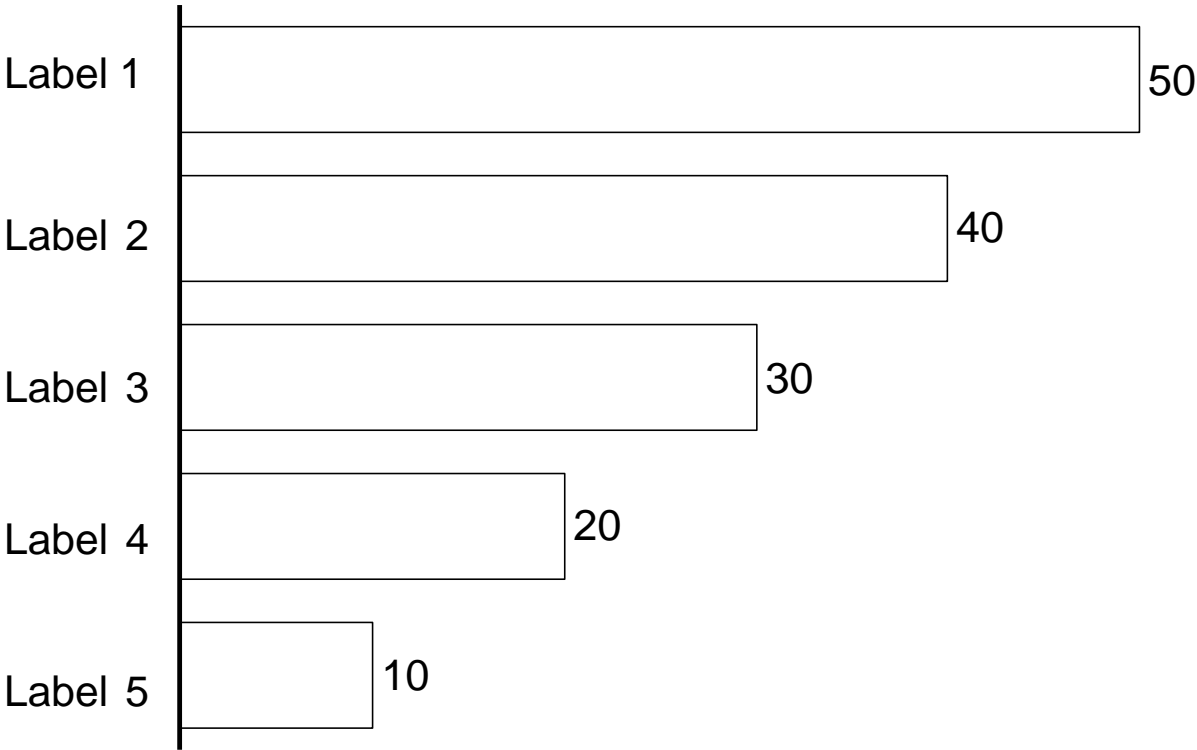

* Footnote

BAR 2

Unit of measure

Title
Unit of measure

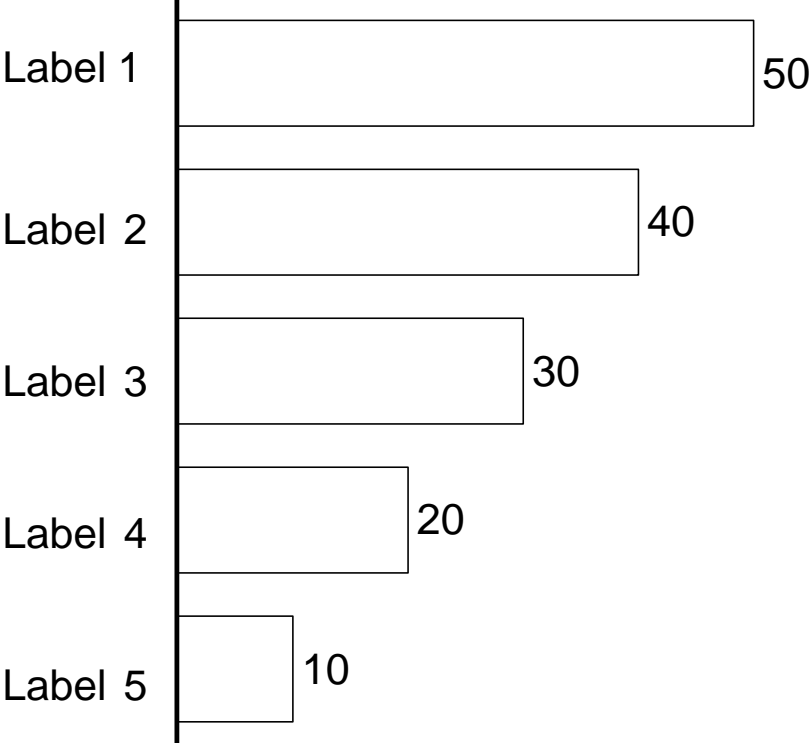

Title
Unit of measure

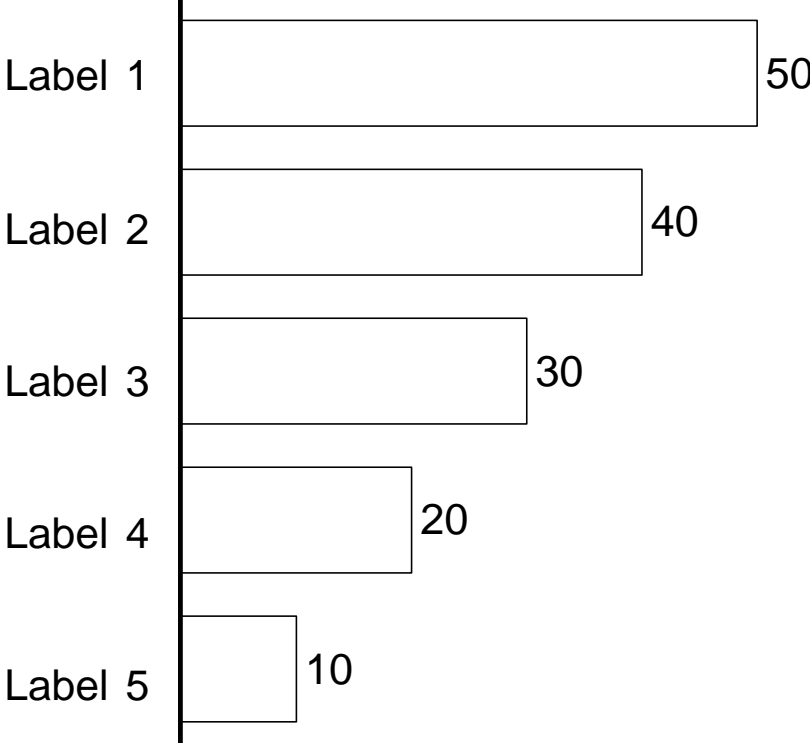

* Footnote

BAR BUTTED

Unit of measure

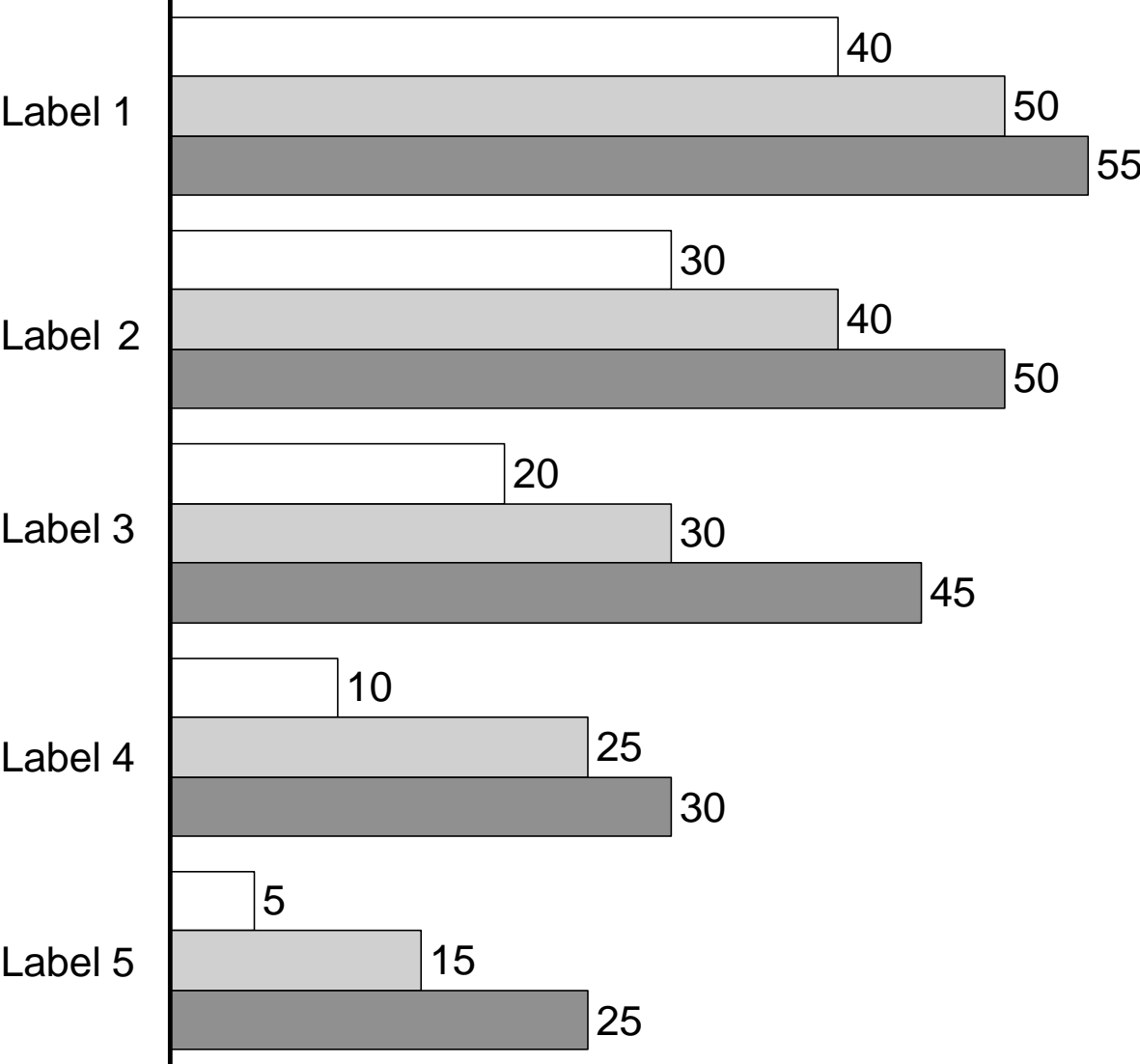

* Footnote

BAR STACKED

Unit of measure

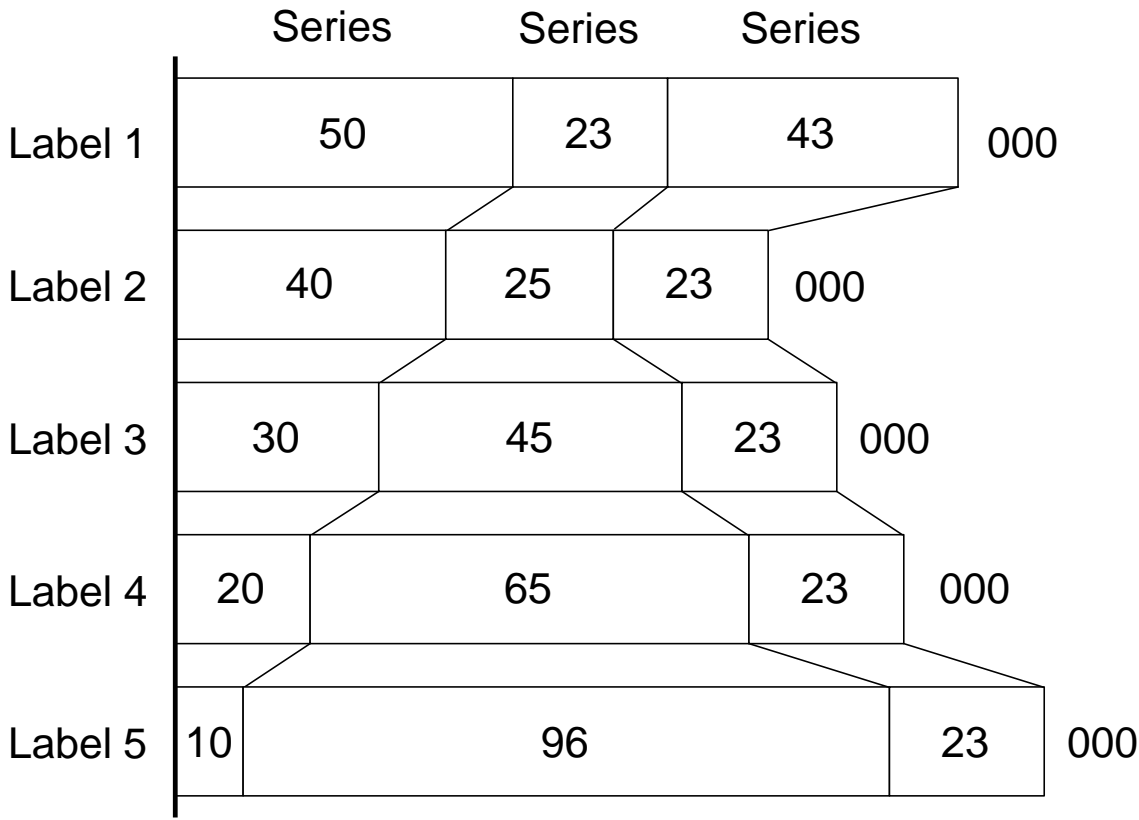

* Footnote

BAR STACKED 100%

Unit of measure

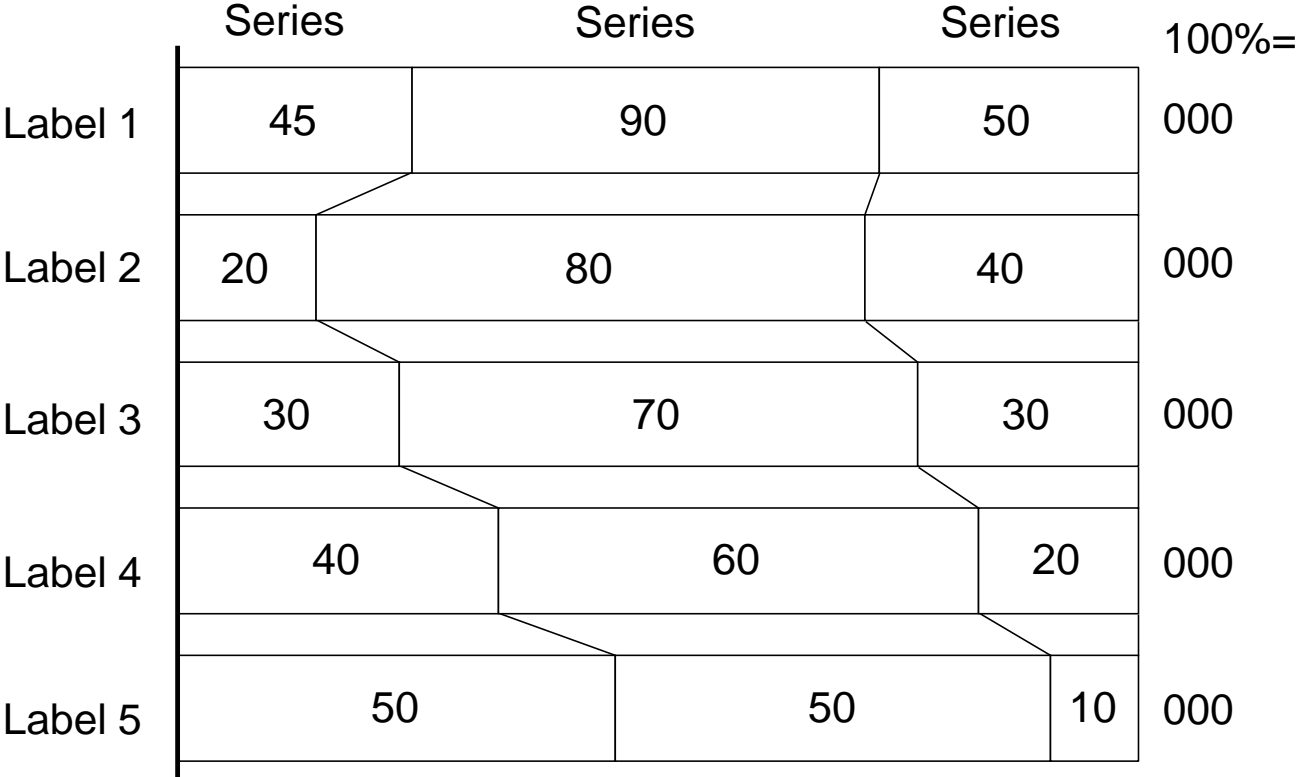

* Footnote

BUBBLE

Unit of measure

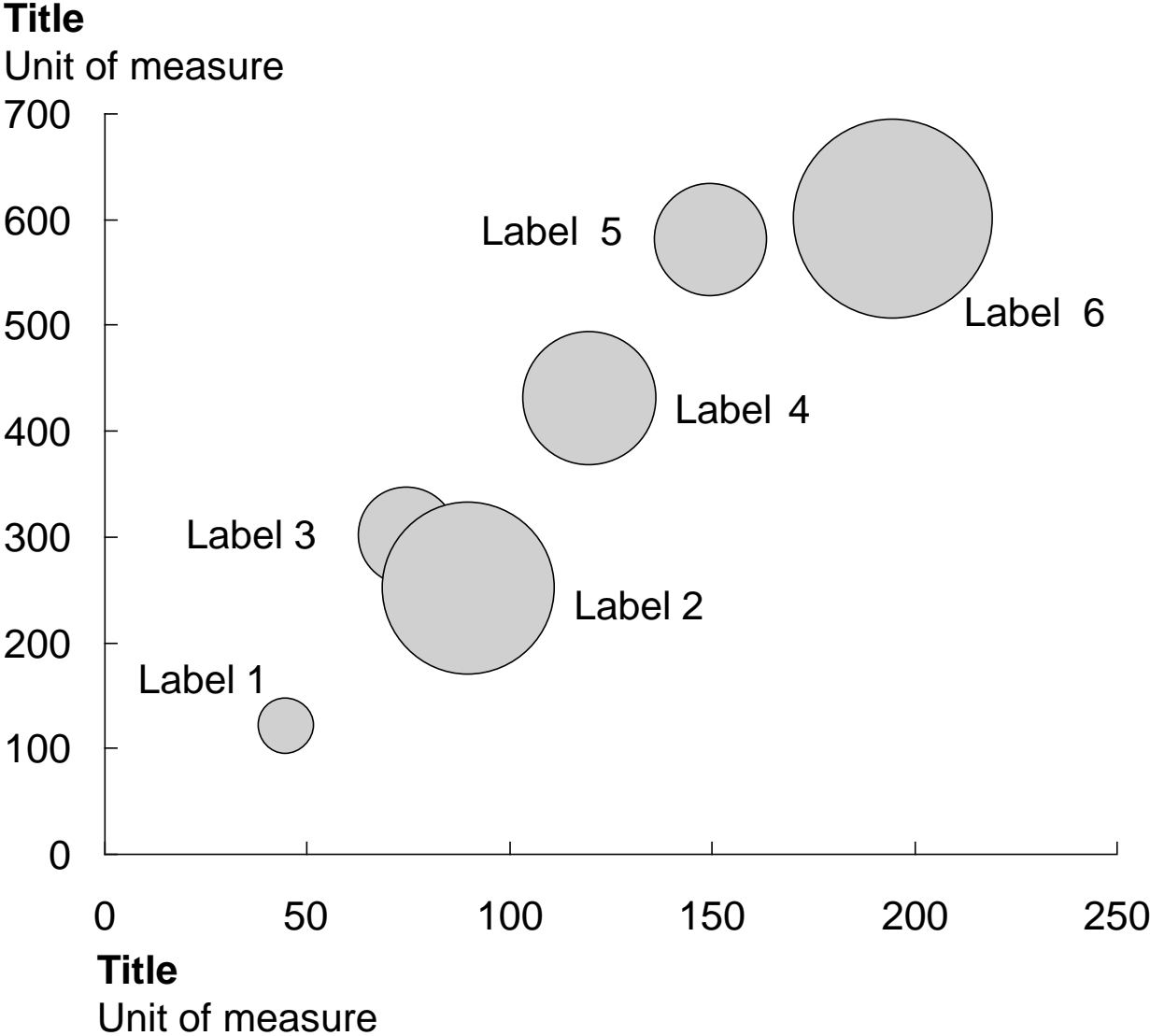

* Footnote

COLUMN

Unit of measure

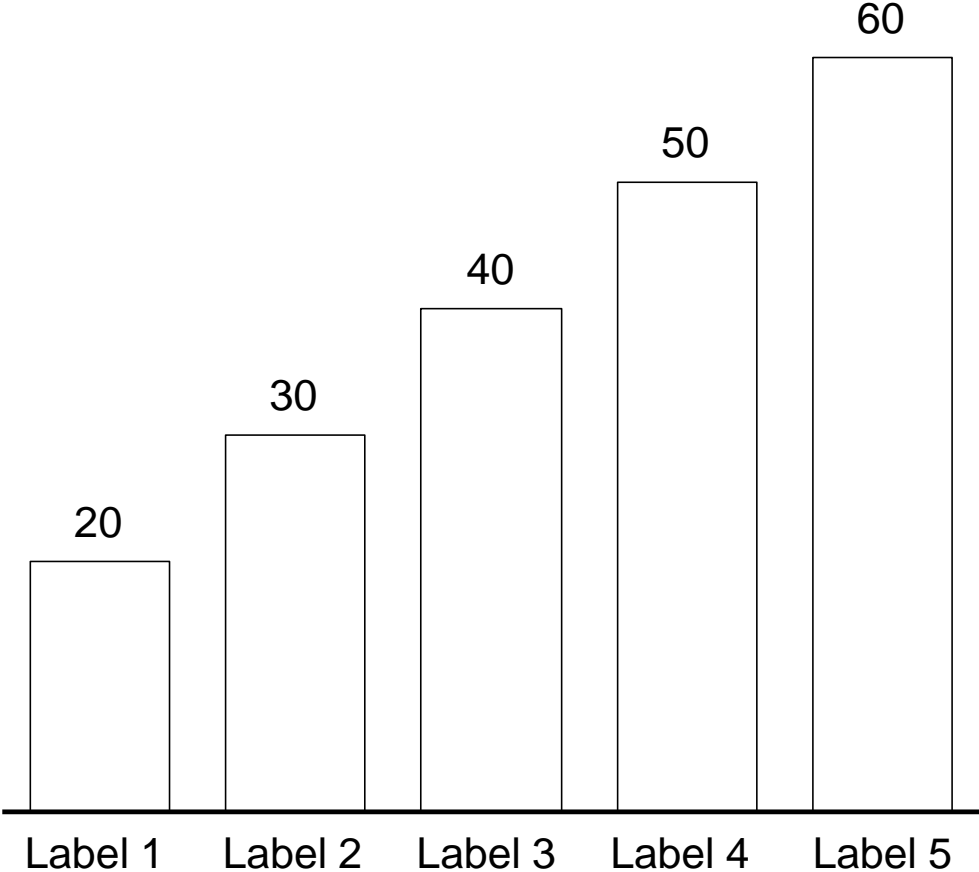

* Footnote

COLUMN 2

Unit of measure

Title

Unit of measure

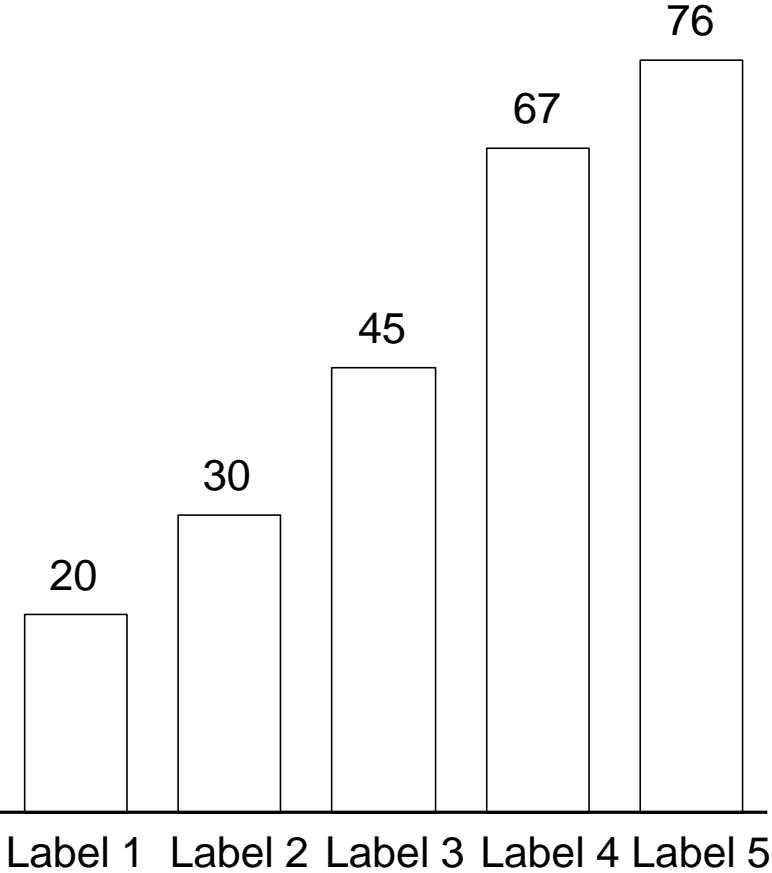

Title

Unit of measure

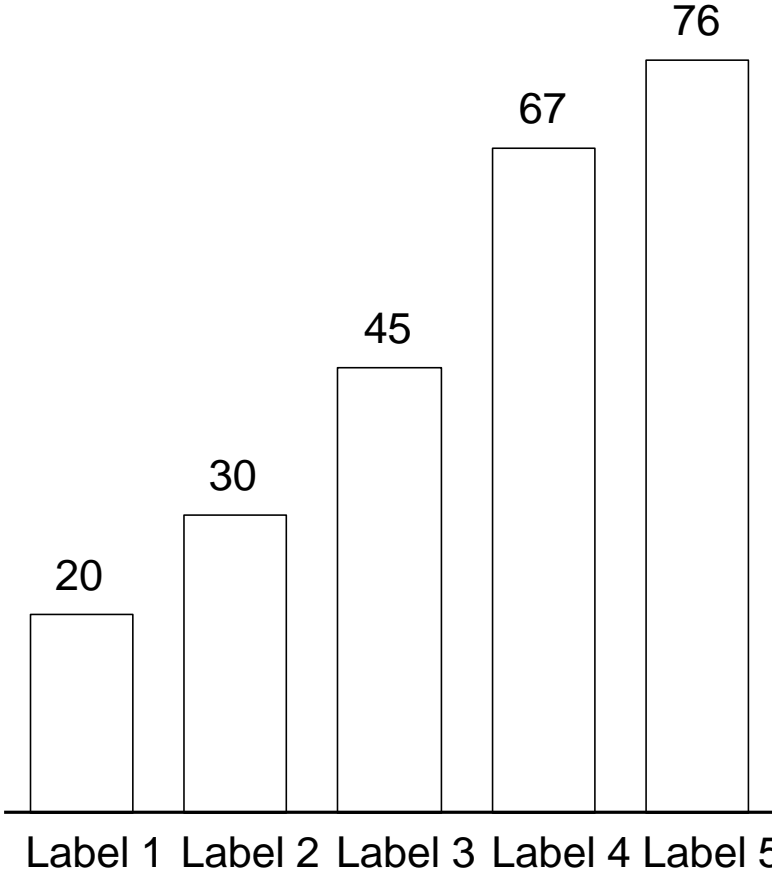

* Footnote

COLUMN BUTTED

Unit of measure

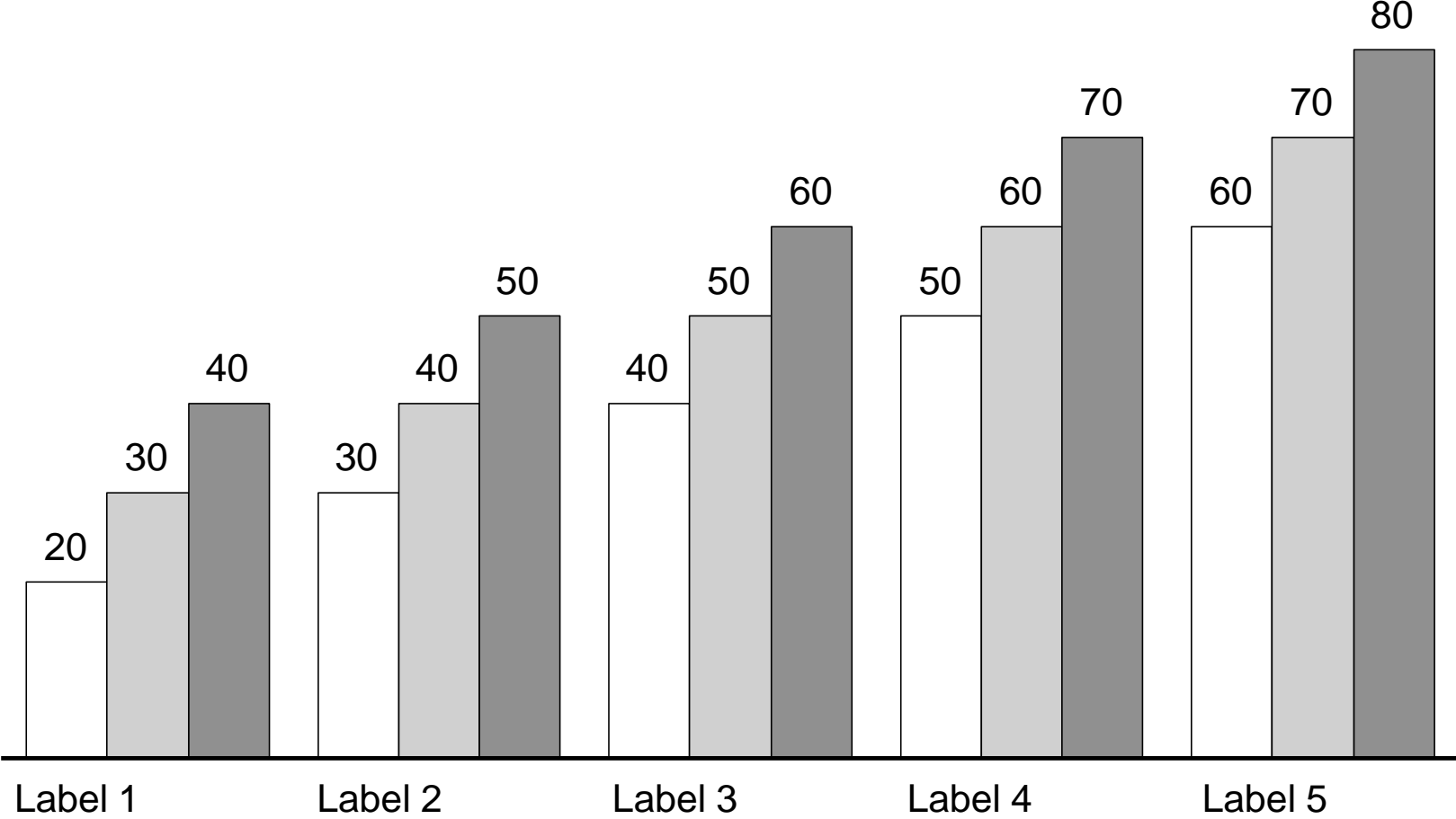

* Footnote

COLUMN STACKED

Unit of measure

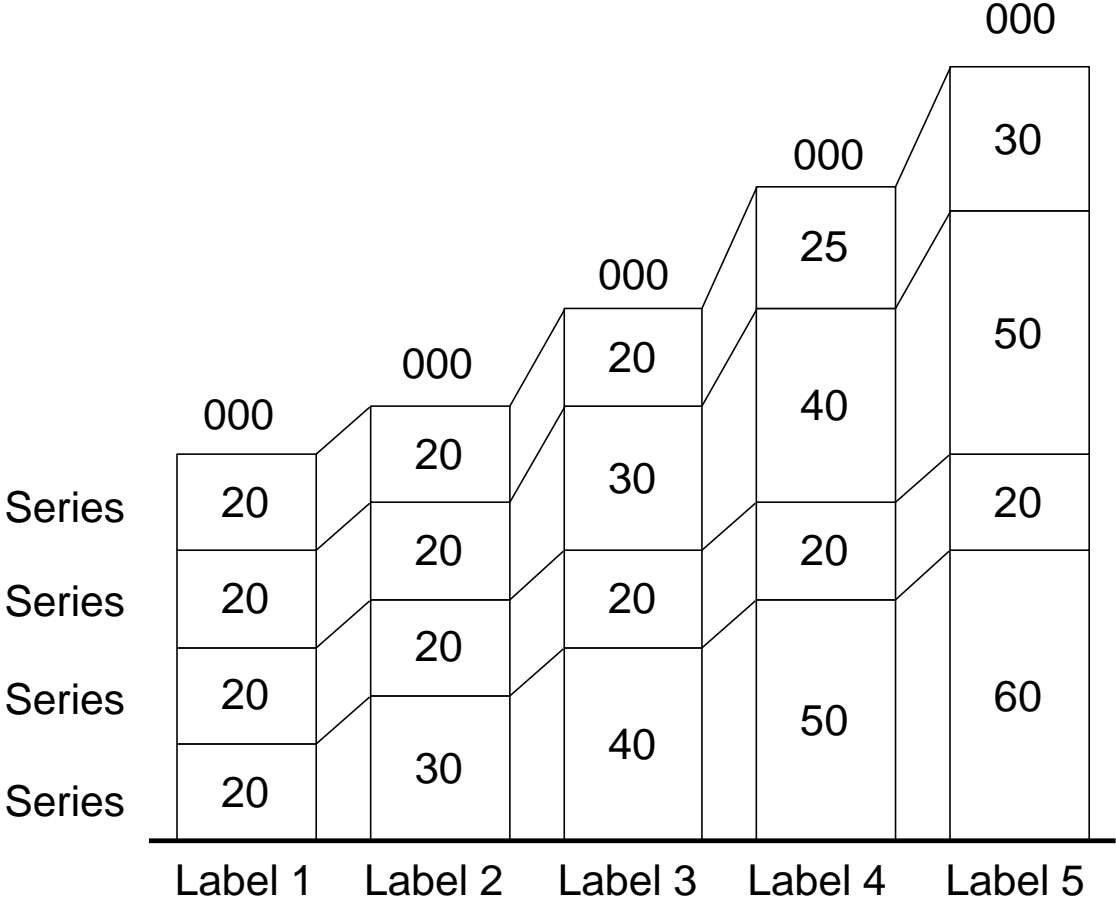

* Footnote

COLUMN STACKED 100%

Unit of measure

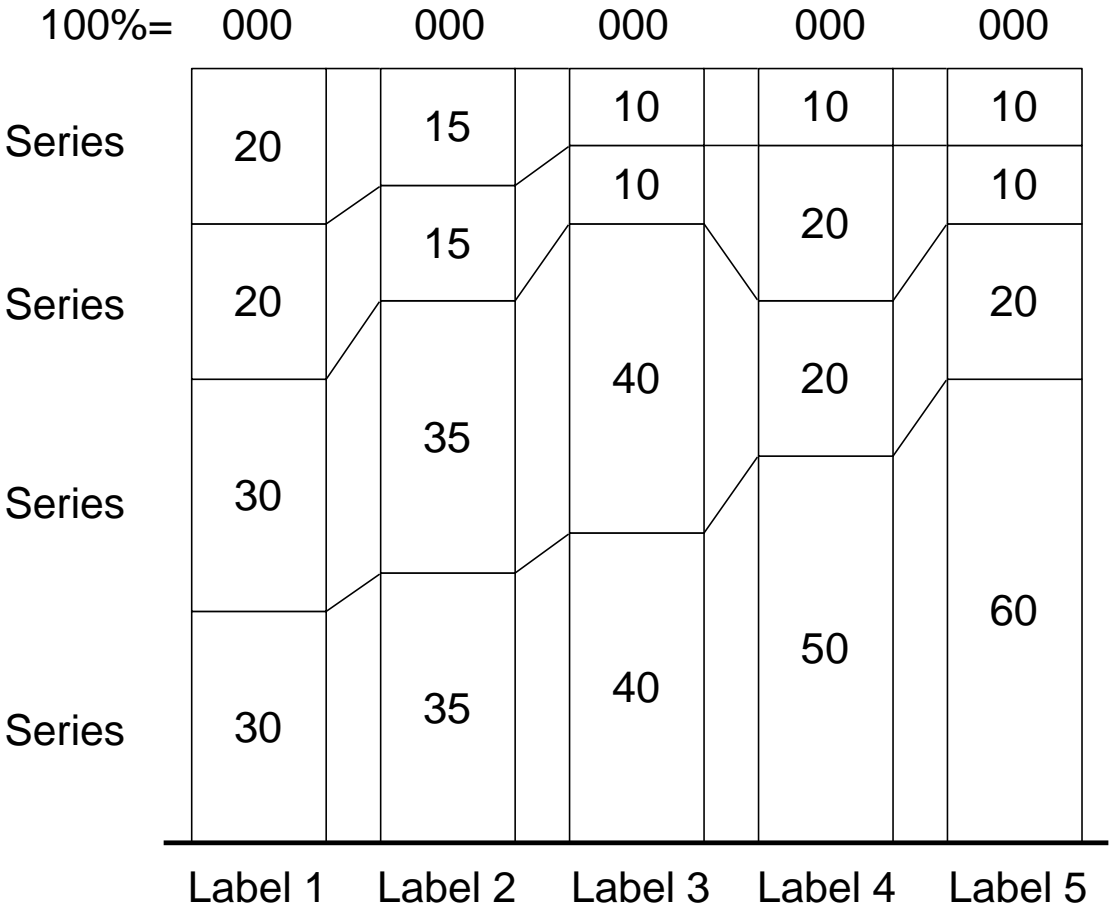

* Footnote

COMBO PIE SEGMENT COLUMN

Unit of measure

Title

Unit of measure

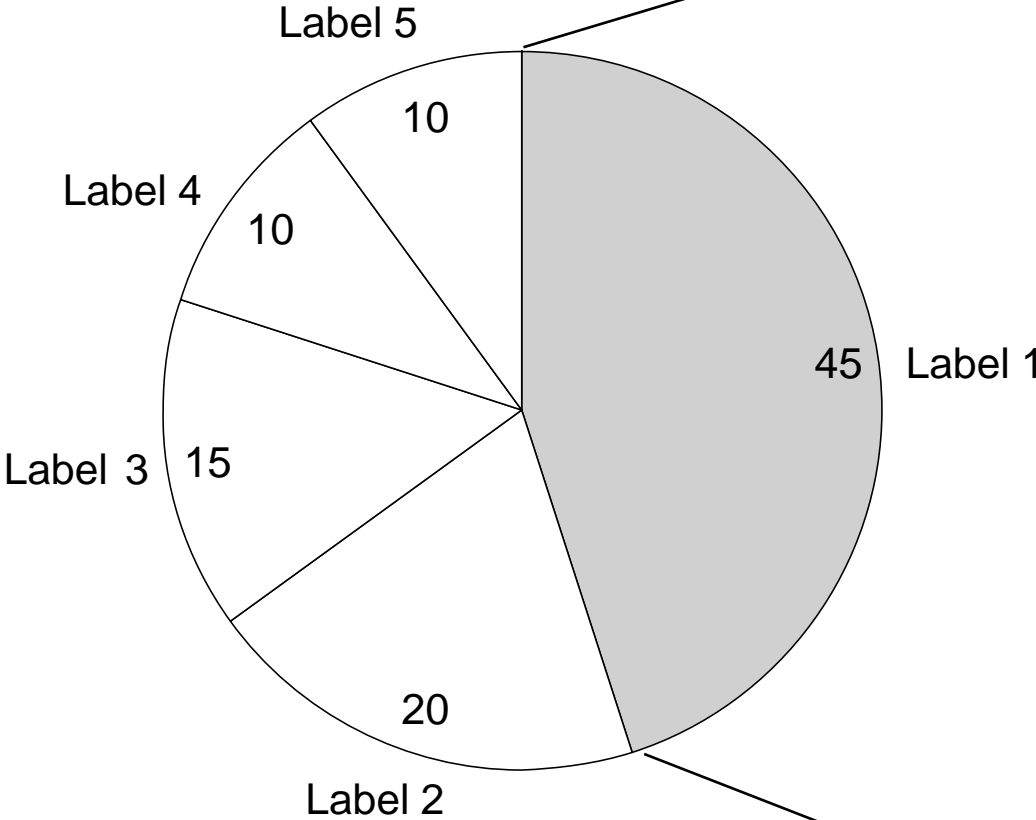

Title

Unit of measure

100% = 000

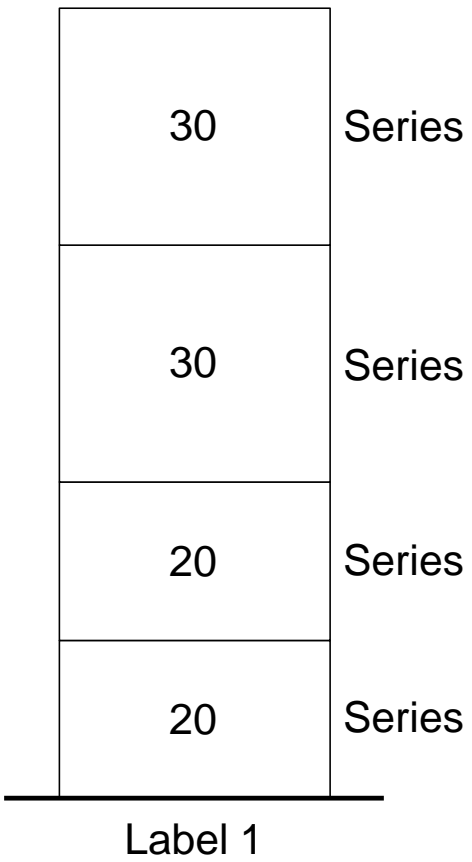

* Footnote

COST CURVE

Unit of measure

Title

Unit of measure

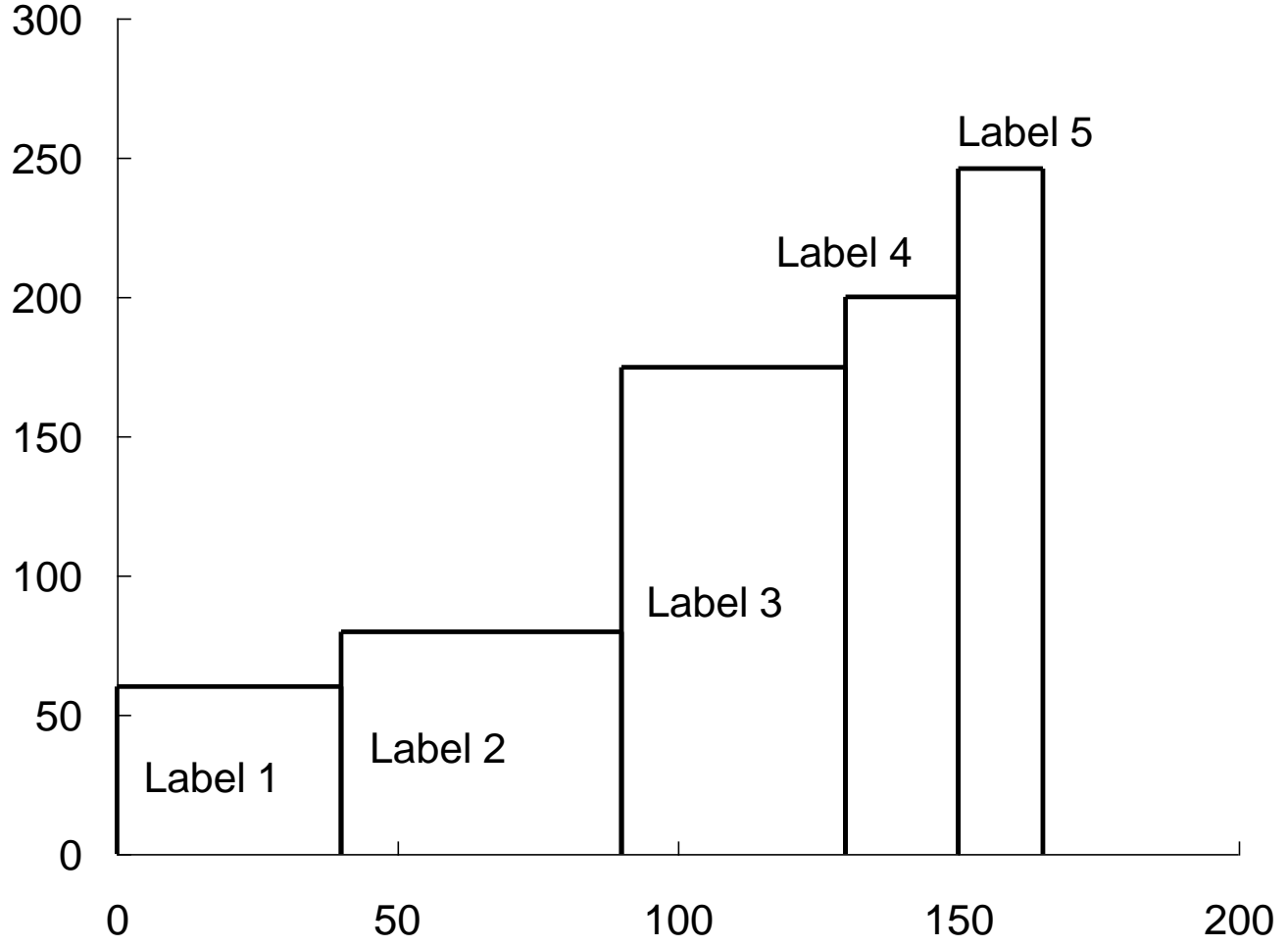

Title

Unit of measure

* Footnote

Source: Source

DUAL COLUMN LINE

Unit of measure

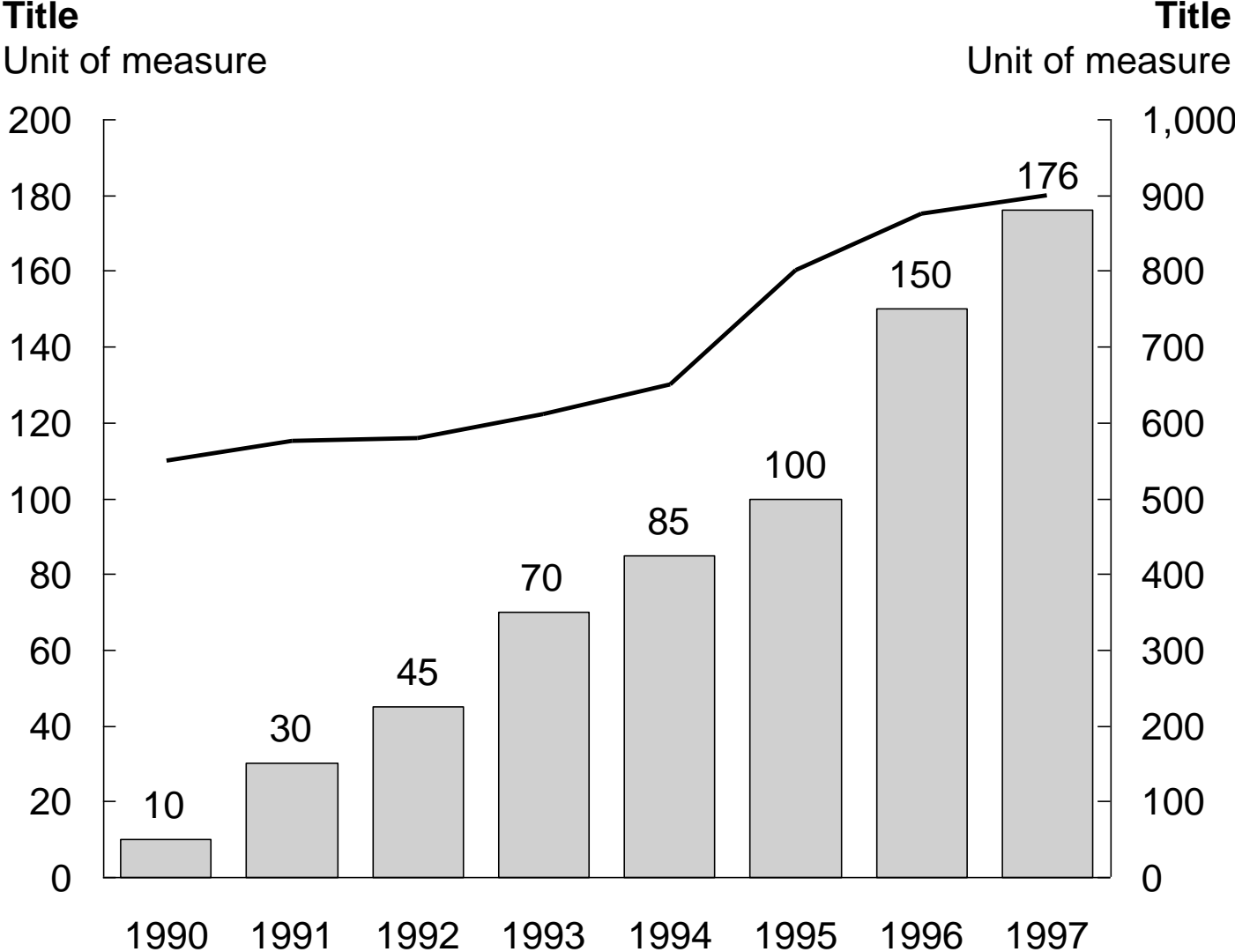

* Footnote

DUAL LINE

Unit of measure

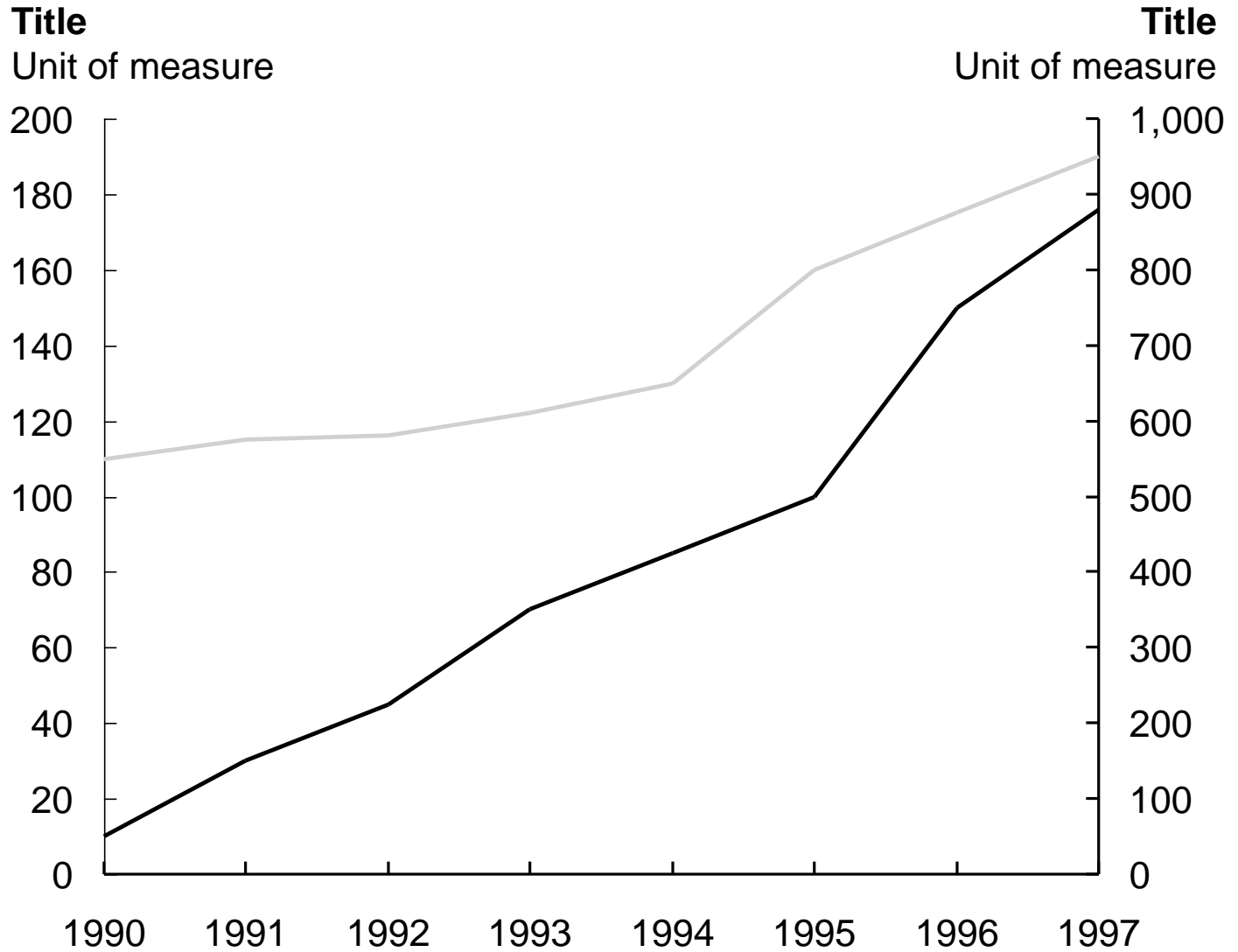

* Footnote

Source: Source

LINE

Unit of measure

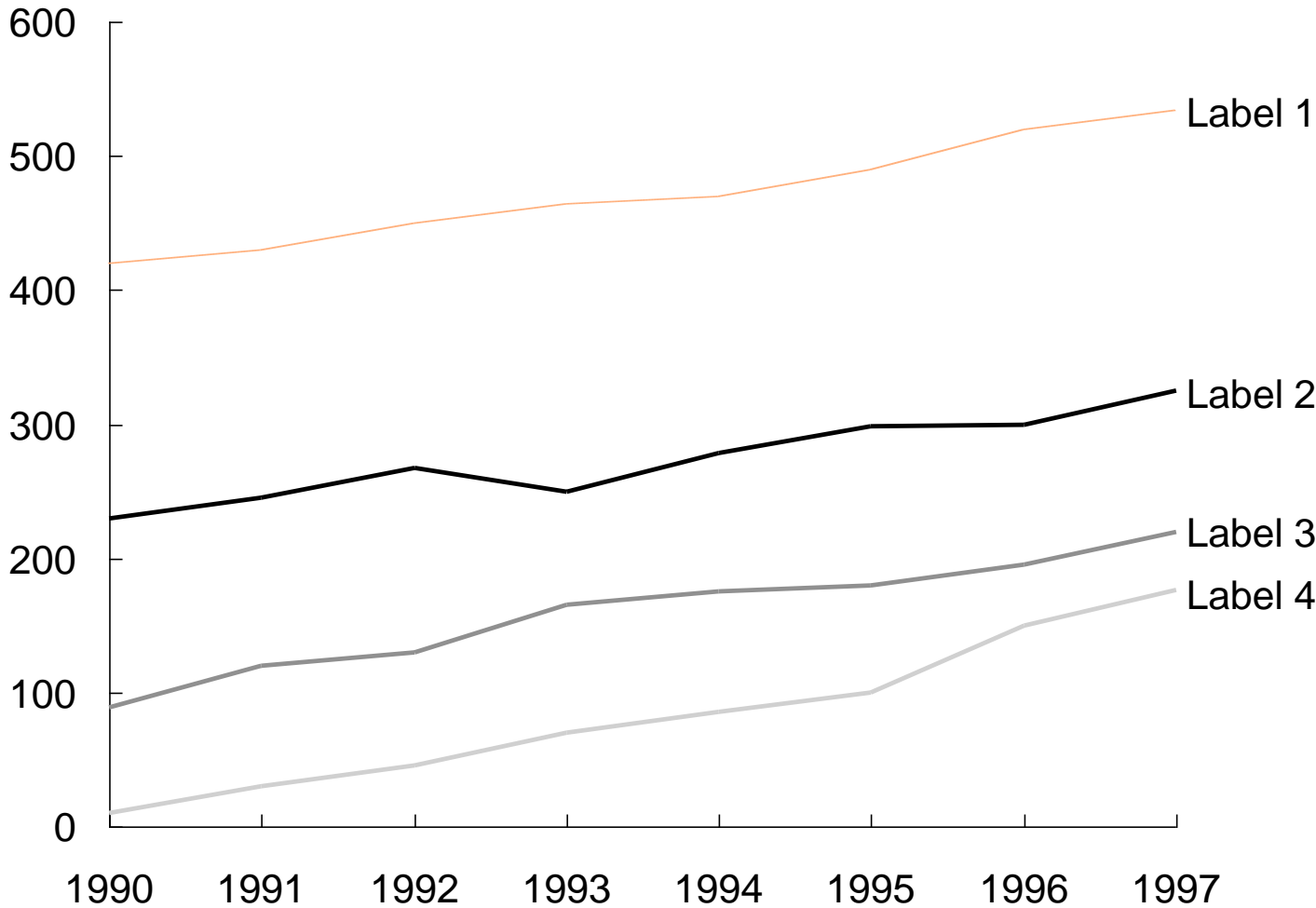

* Footnote

PIE

Unit of measure

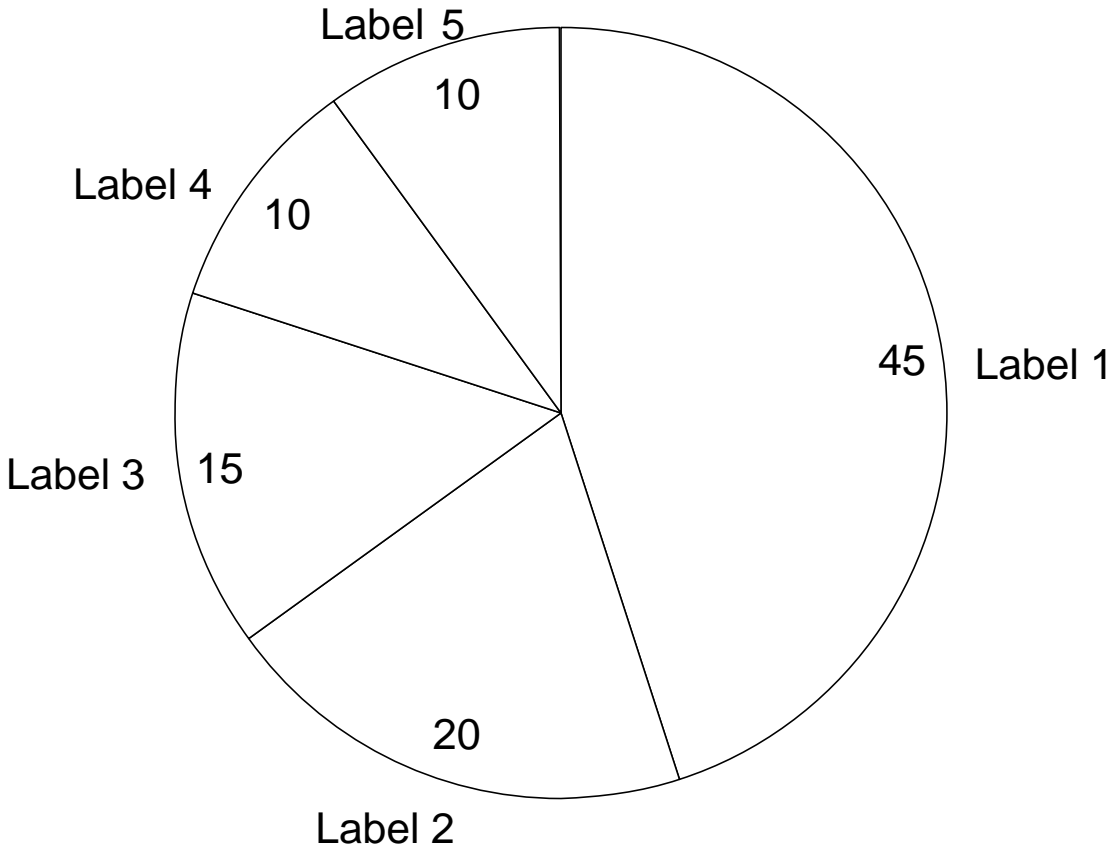

* Footnote

PIE 2

Unit of measure

Title

Unit of measure

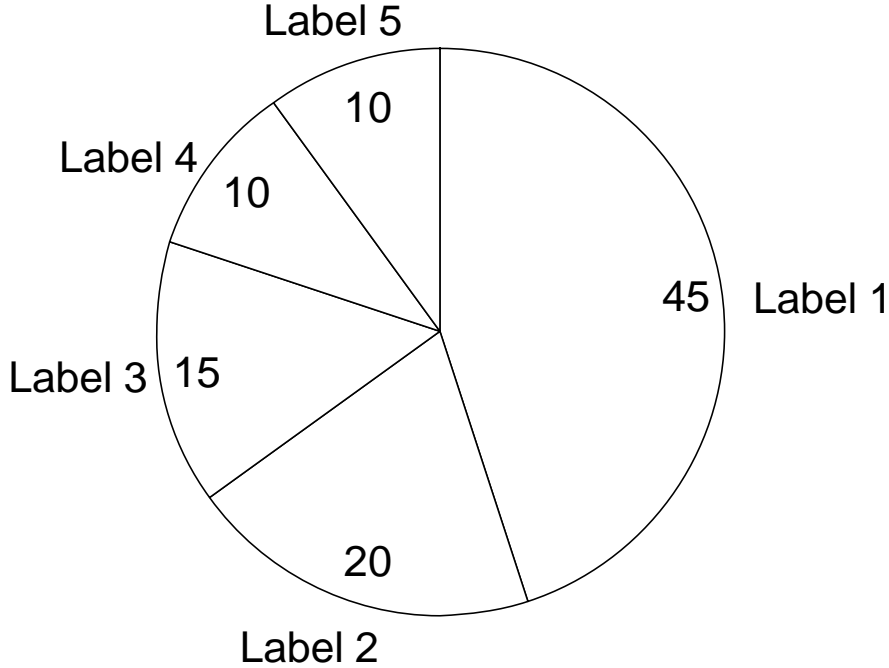

Title

Unit of measure

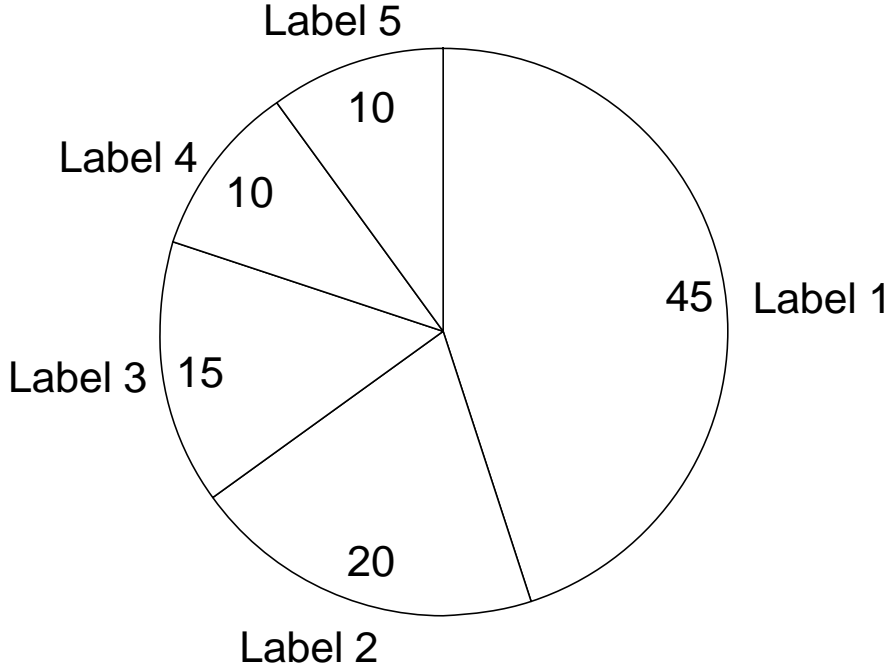

* Footnote

RANGE HIGH LOW

Unit of measure

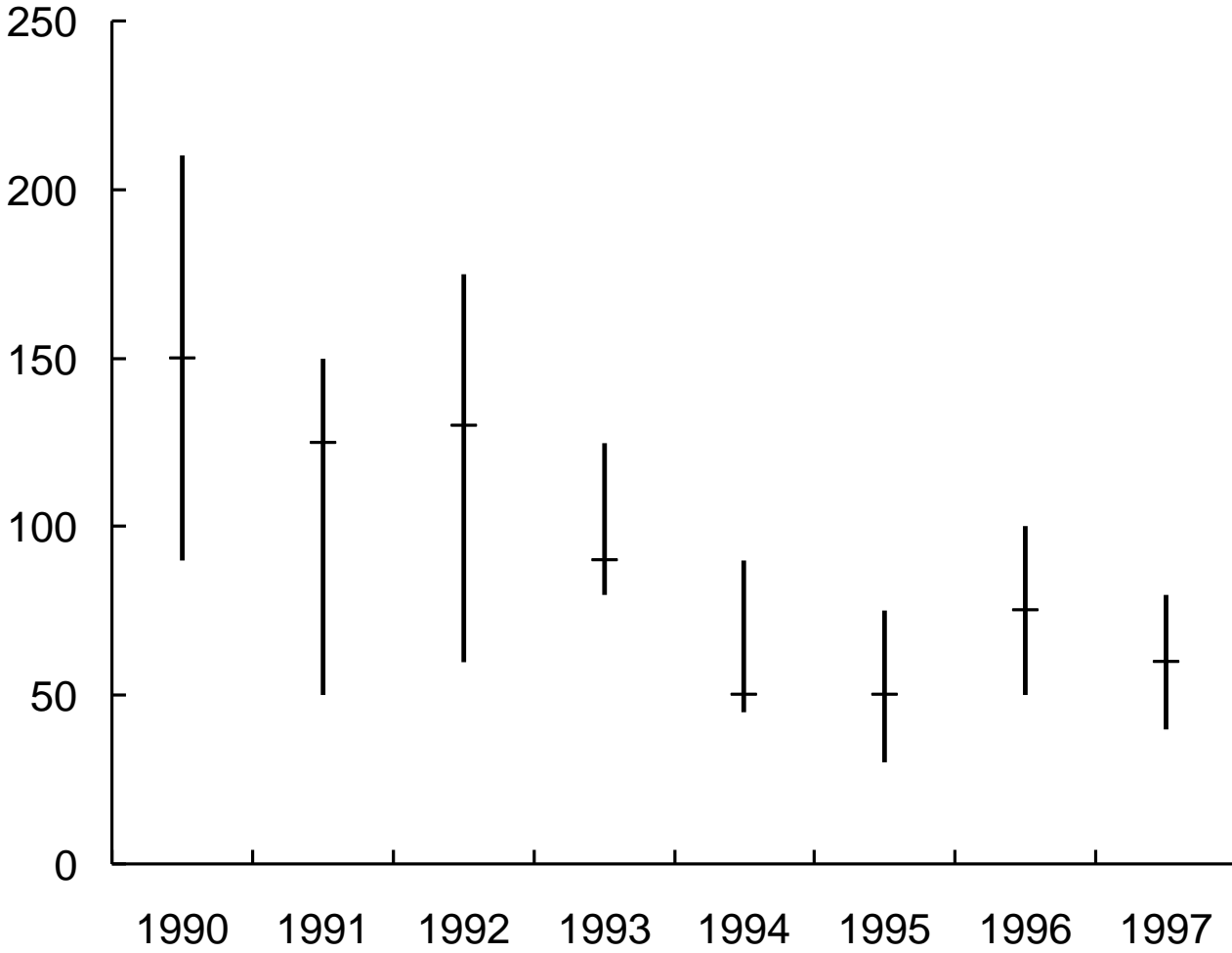

* Footnote

SCATTER X & Y

Unit of measure

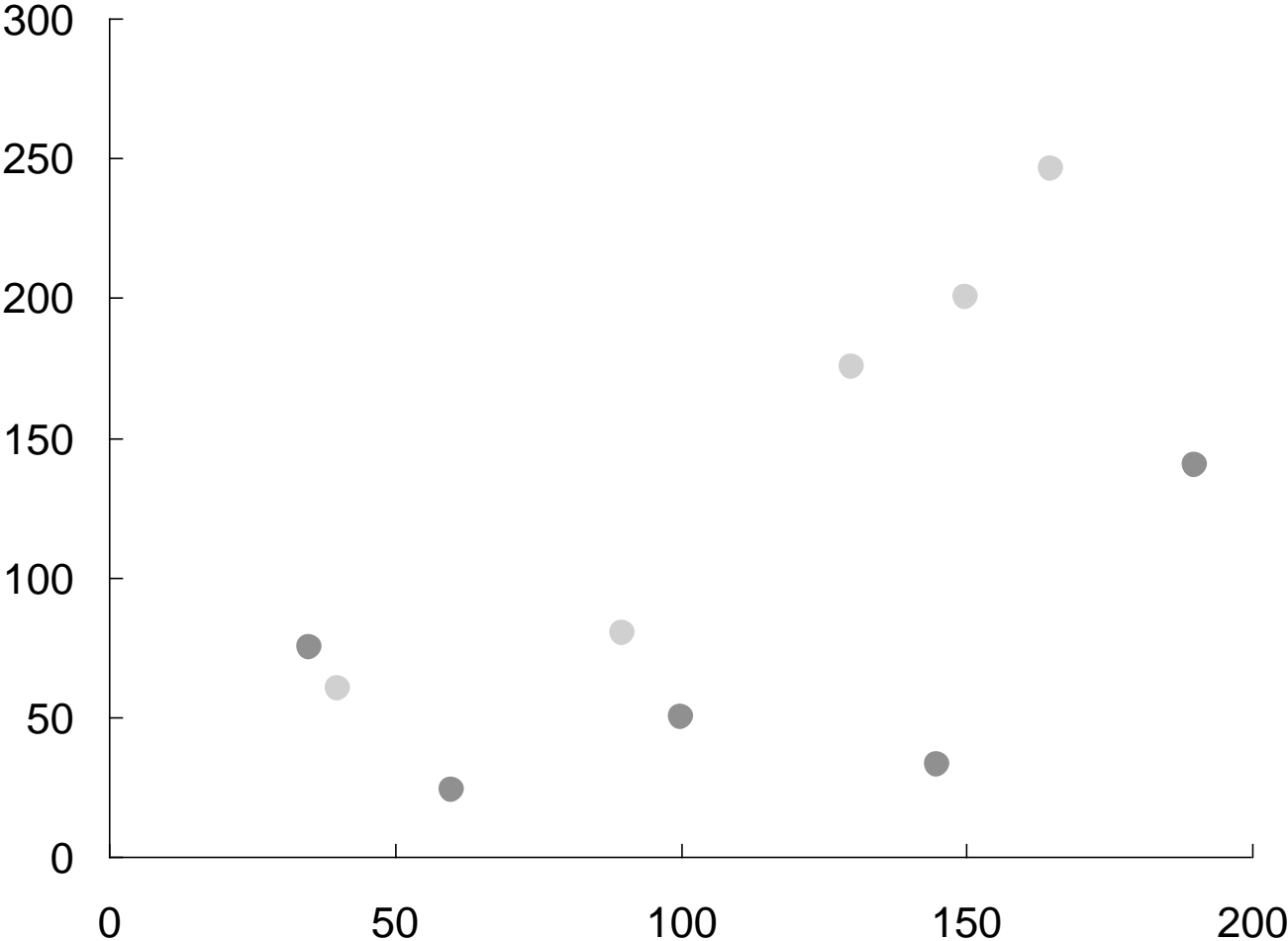

* Footnote

WATERFALL BAR

Unit of measure

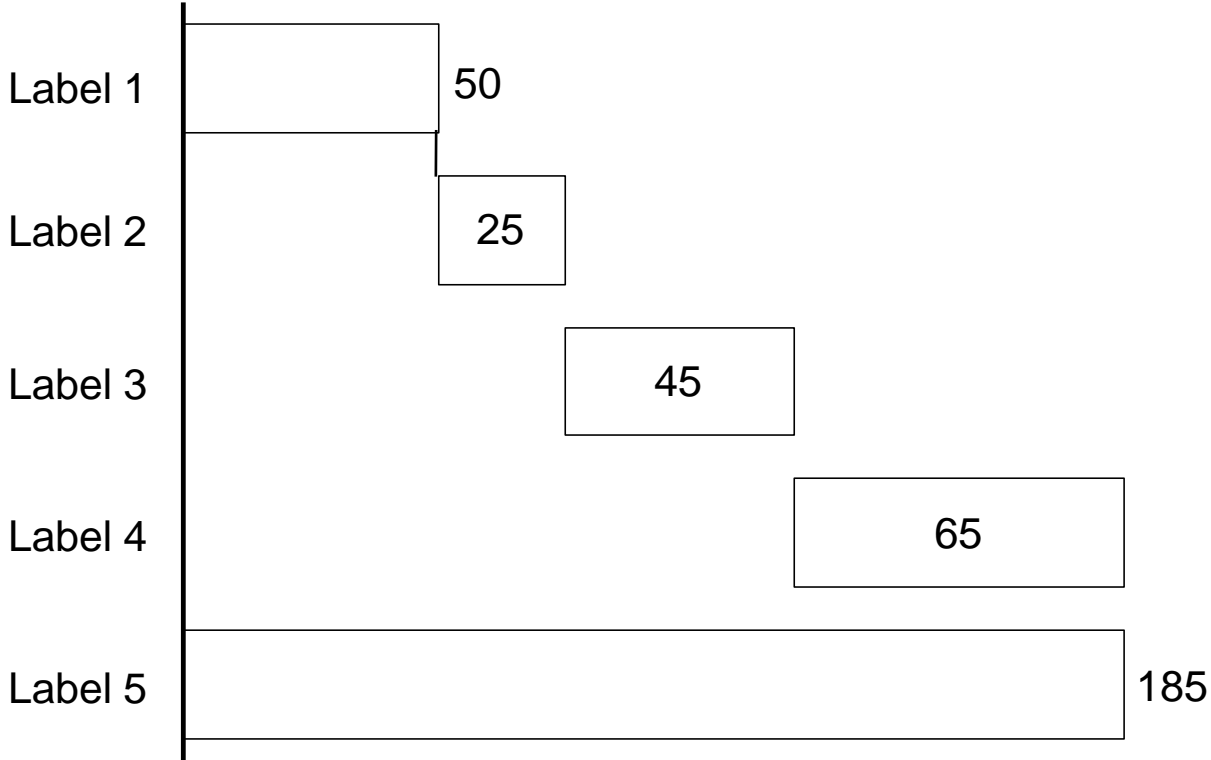

* Footnote

WATERFALL COLUMN

Unit of measure

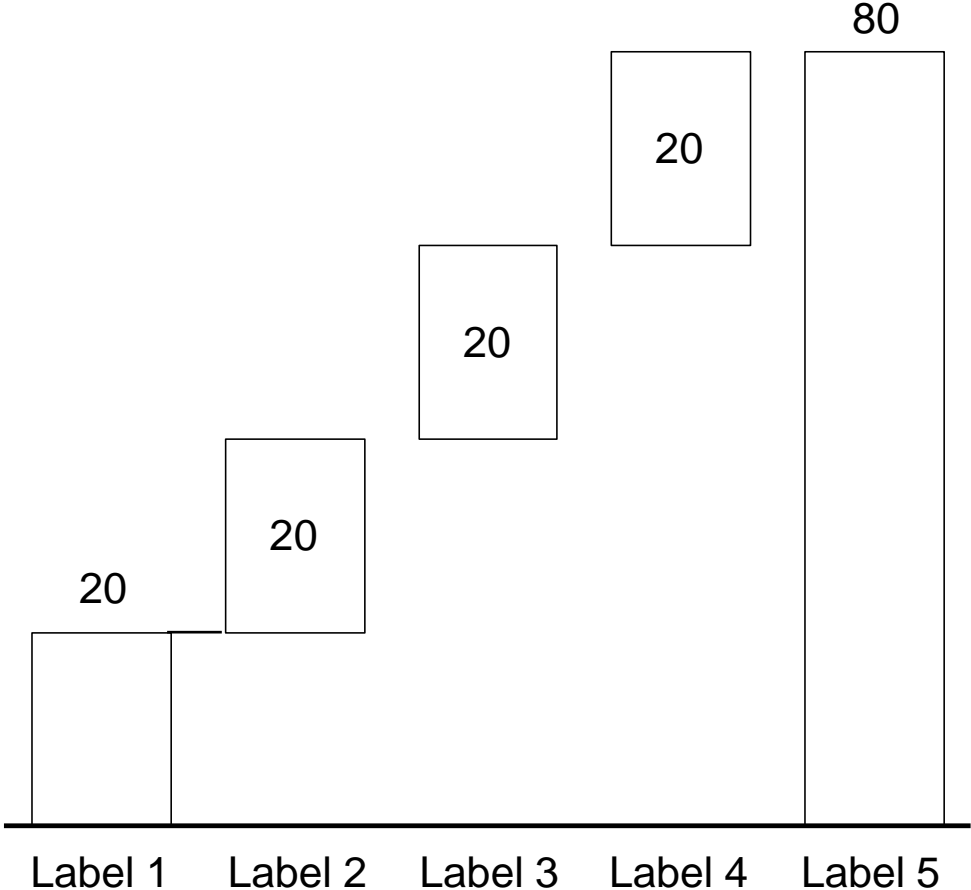

* Footnote

CONFIDENTIAL

Frequently Used Template

Named Objects

Template

June 2002

This report is solely for the use of client personnel. No part of it may be circulated, quoted, or reproduced for distribution outside the client organization without prior written approval from McKinsey & Company. This material was used by McKinsey & Company during an oral presentation; it is not a complete record of the discussion.

ARROWS

Unit of measure

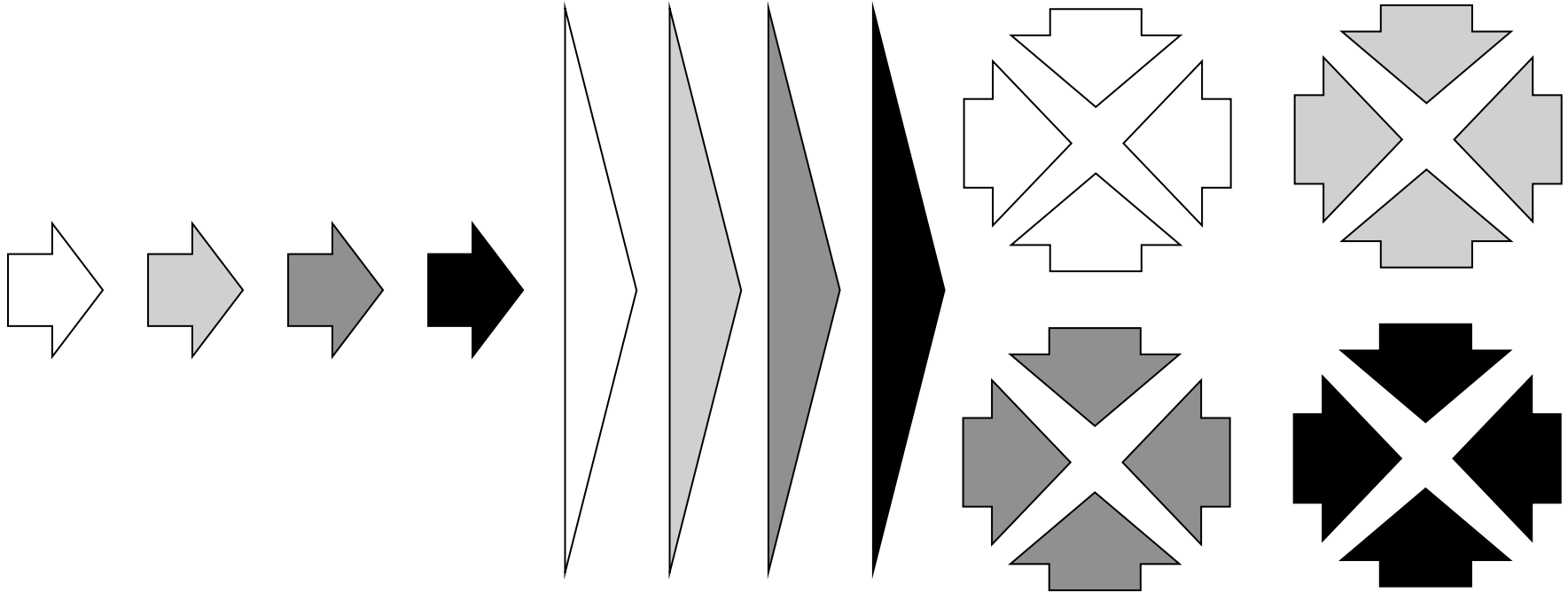

* Footnote

DISCLAIMERS CLIENT

Unit of measure

* Footnote

Source: Source

This report is solely for the use of client personnel. No part of it may be circulated, quoted, or reproduced for distribution outside the client organization without prior written approval from McKinsey & Company.

DISCLAIMERS INTERNAL

Unit of measure

This report contains information that is confidential and proprietary to McKinsey & Company and is solely for the use of McKinsey & Company personnel. No part of it may be used, circulated, quoted, or reproduced for distribution outside McKinsey & Company. If you are not the intended recipient of this report, you are hereby notified that the use, circulation, quoting, or reproducing of this report is strictly prohibited and may be unlawful.

* Footnote

Source: Source

DISCLAIMERS PRESENTATION

Unit of measure

* Footnote

Source: Source

This report is solely for the use of client personnel. No part of it may be circulated, quoted, or reproduced for distribution outside the client organization without prior written approval from McKinsey & Company. This material was used by McKinsey & Company during an oral presentation; it is not a complete record of the discussion.

LEGENDS

Unit of measure

-  Legend
-  Legend
-  Legend

* Footnote

MCKINSEY LOGO

Unit of measure

McKinsey & Company

* Footnote

MISC

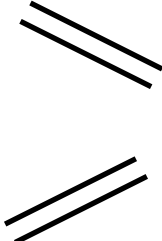

Unit of measure







* Footnote

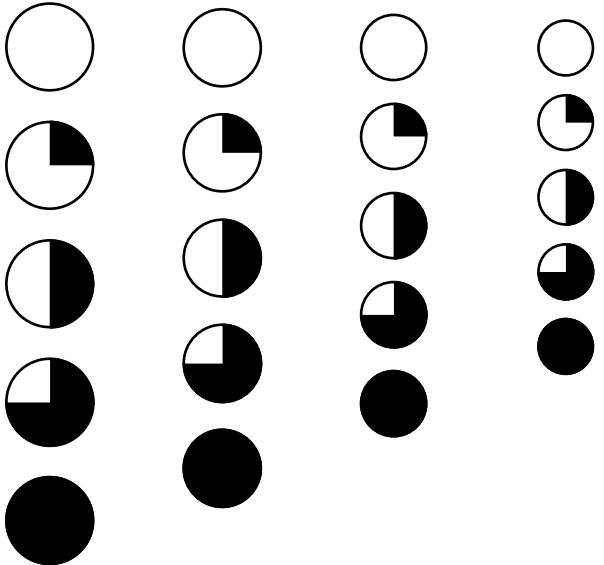

MOONS

Unit of measure

-  Legend
-  Legend
-  Legend



-  Low
-  Medium
-  High

-  Low
-  Medium
-  High

* Footnote

STICKER

Unit of measure

STICKER

ILLUSTRATIVE

CONFIDENTIAL

PRELIMINARY

DRAFT

ESTIMATE

EXAMPLE

FOR DISCUSSION ONLY

FOR DISCUSSION

* Footnote

STICKER OTHER

Unit of measure

DISCUSSION DRAFT

DISGUISED

DRAFT FOR DISCUSSION

SAMPLE

CONCEPTUAL

PROPOSED

PRELIMINARY
DRAFT

PRELIMINARY
ESTIMATE

CONFIDENTIAL
DISCUSSION DRAFT

DISGUISED
CLIENT EXAMPLE

ROUGH ESTIMATE

TO BE COMPLETED

BACKUP

HYPOTHESIS

STRAW MAN

REVISED

* Footnote

WORLD MAP

Unit of measure

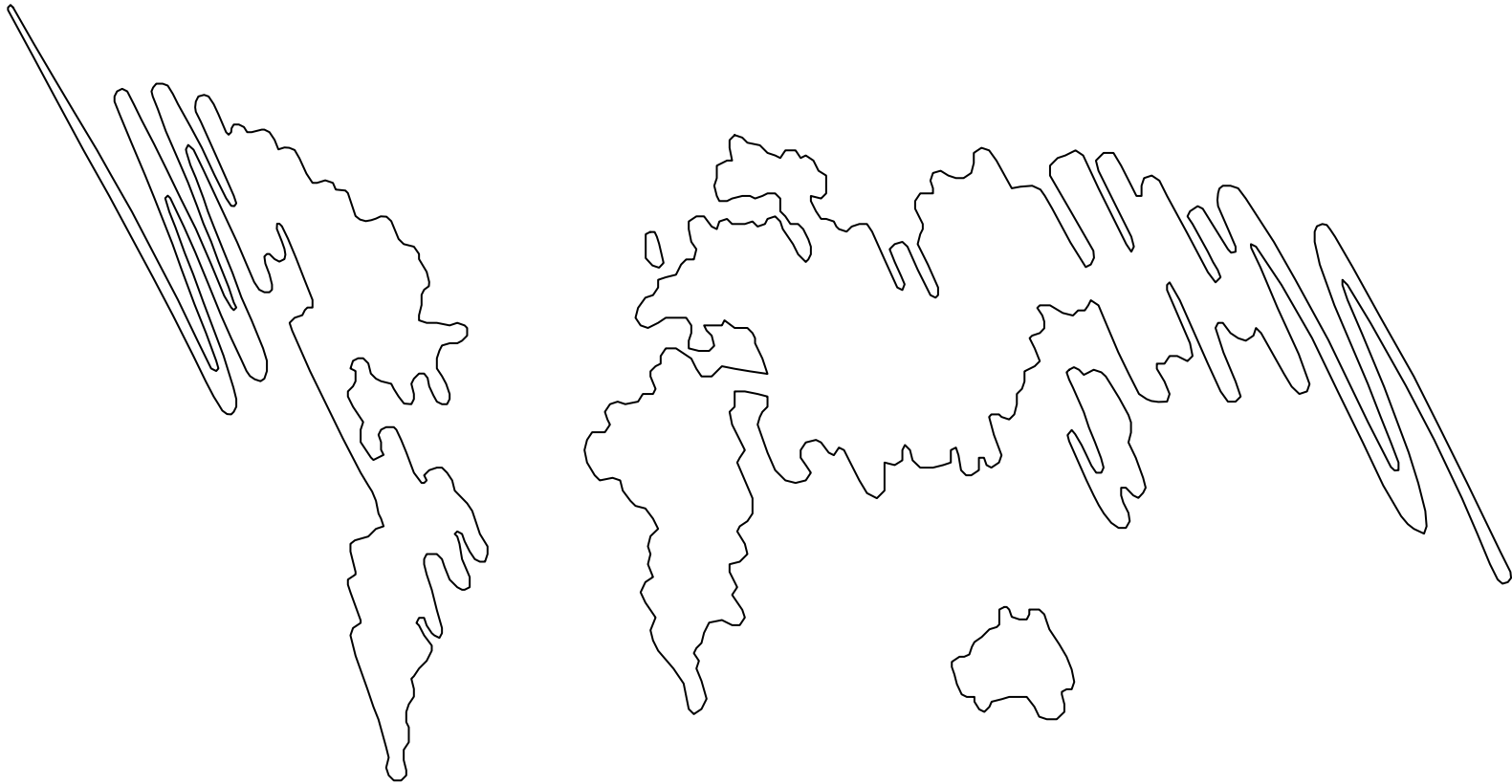

* Footnote

CONFIDENTIAL

Frequently Used Template

Text

Template

June 2002

This report is solely for the use of client personnel. No part of it may be circulated, quoted, or reproduced for distribution outside the client organization without prior written approval from McKinsey & Company. This material was used by McKinsey & Company during an oral presentation; it is not a complete record of the discussion.

PPT TABLE 2

Unit of measure

Heading

Heading

Text

Text

* Footnote

PPT TABLE 3

Unit of measure

Heading

Heading

Heading

Text

Text

Text

* Footnote

PPT TABLE 4

Unit of measure

Heading

Heading

Heading

Heading

Text

Text

Text

Text

* Footnote

PPT TABLE 5

Unit of measure

Heading	Heading	Heading	Heading	Heading
Text	Text	Text	Text	Text

* Footnote

PPT TABLE 6

Unit of measure

Heading	Heading	Heading	Heading	Heading	Heading
Text	Text	Text	Text	Text	Text

* Footnote

CONFIDENTIAL

Frequently Used Template

SEO VA

Template

June 2002

This report is solely for the use of client personnel. No part of it may be circulated, quoted, or reproduced for distribution outside the client organization without prior written approval from McKinsey & Company. This material was used by McKinsey & Company during an oral presentation; it is not a complete record of the discussion.

Unit of measure



- Text



- Text



- Text

* Footnote

Unit of measure

Title

- Text

Title

- Text



* Footnote

Unit of measure

Title

- Text

Title

- Text

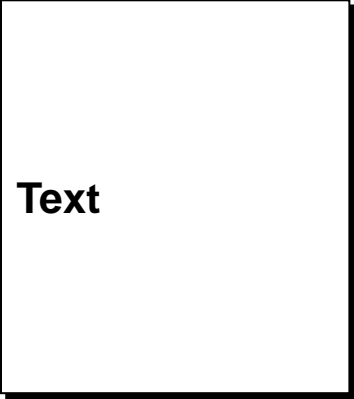

* Footnote

EXHIBIT TITLE

Title

Text

•

Text

•

Text

•



Text

* Footnote

EXHIBIT TITLE

Title

Text

-

Text

-

Text

-

* Footnote

EXHIBIT TITLE

Title

Title

•

•

Text

•

•

Text

•

•

Text

* Footnote

EXHIBIT TITLE

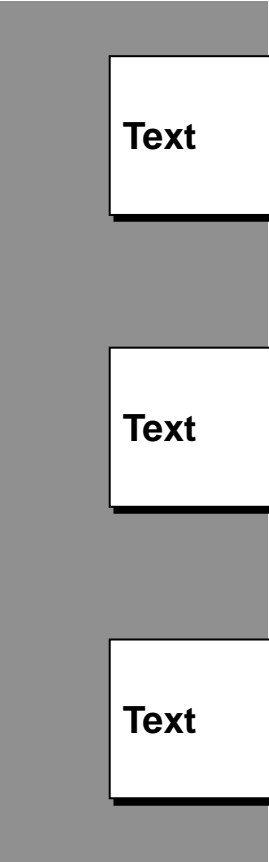

Text

Text

Text

Title

•

•

•

Title

•

•

•

Title

•

•

•

* Footnote

2 COLUMN

Title

- Text

Title

- Text

* Footnote

3 COLUMN

Title

- Text

Title

- Text

Title

- Text

* Footnote

4 COLUMN

Title

- Text

Title

- Text

Title

- Text

Title

- Text

* Footnote

5 COLUMN

Title	Title	Title	Title	Title
• Text	• Text	• Text	• Text	• Text

* Footnote

6 COLUMN

Title	Title	Title	Title	Title	Title
• Text	• Text	• Text	• Text	• Text	• Text

* Footnote

7 COLUMN

<u>Title</u>	<u>Title</u>	<u>Title</u>	<u>Title</u>	<u>Title</u>	<u>Title</u>	<u>Title</u>
• Text	• Text	• Text	• Text	• Text	• Text	• Text

* Footnote

8 COLUMN

Text	Text	Text	Text	Text	Text	Text	Text
Text	Text	Text	Text	Text	Text	Text	Text

* Footnote
Source: Source

3-STEP

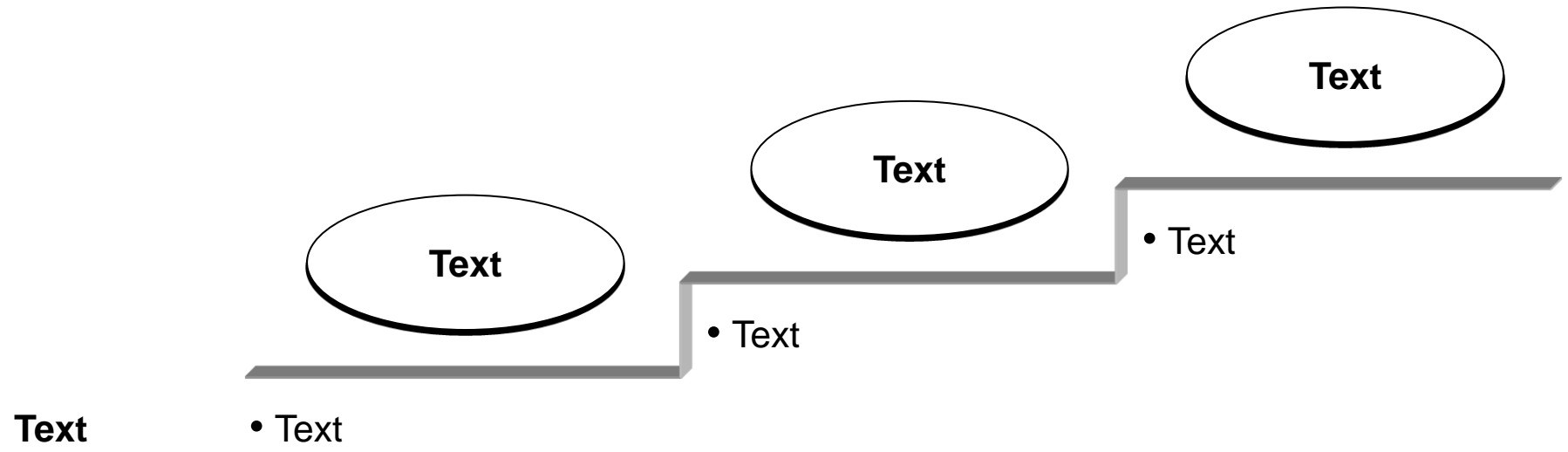

4-STEP

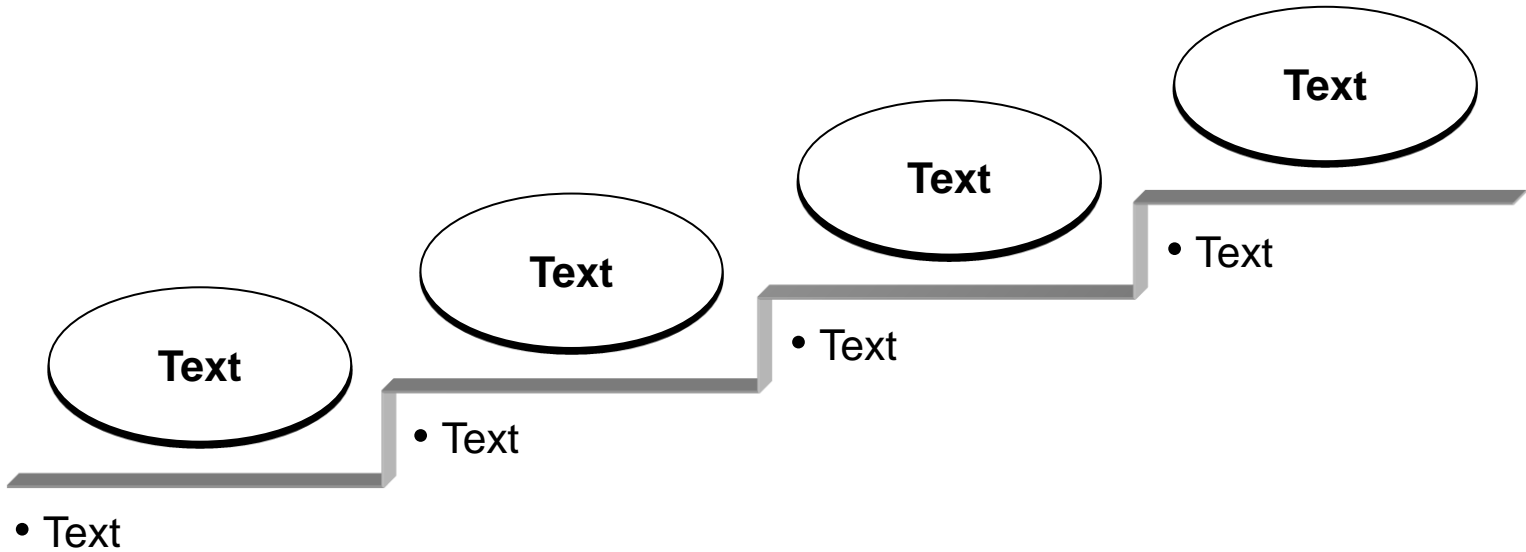

5-STEP

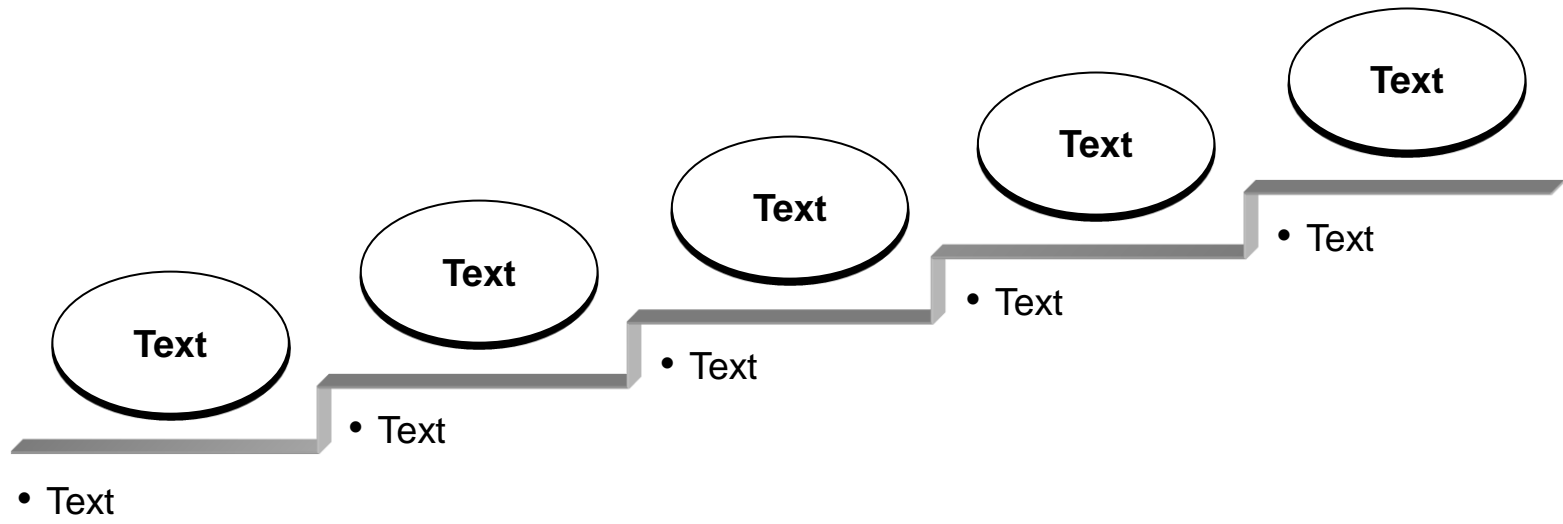

Text

3 HORIZONTAL

Unit of measure

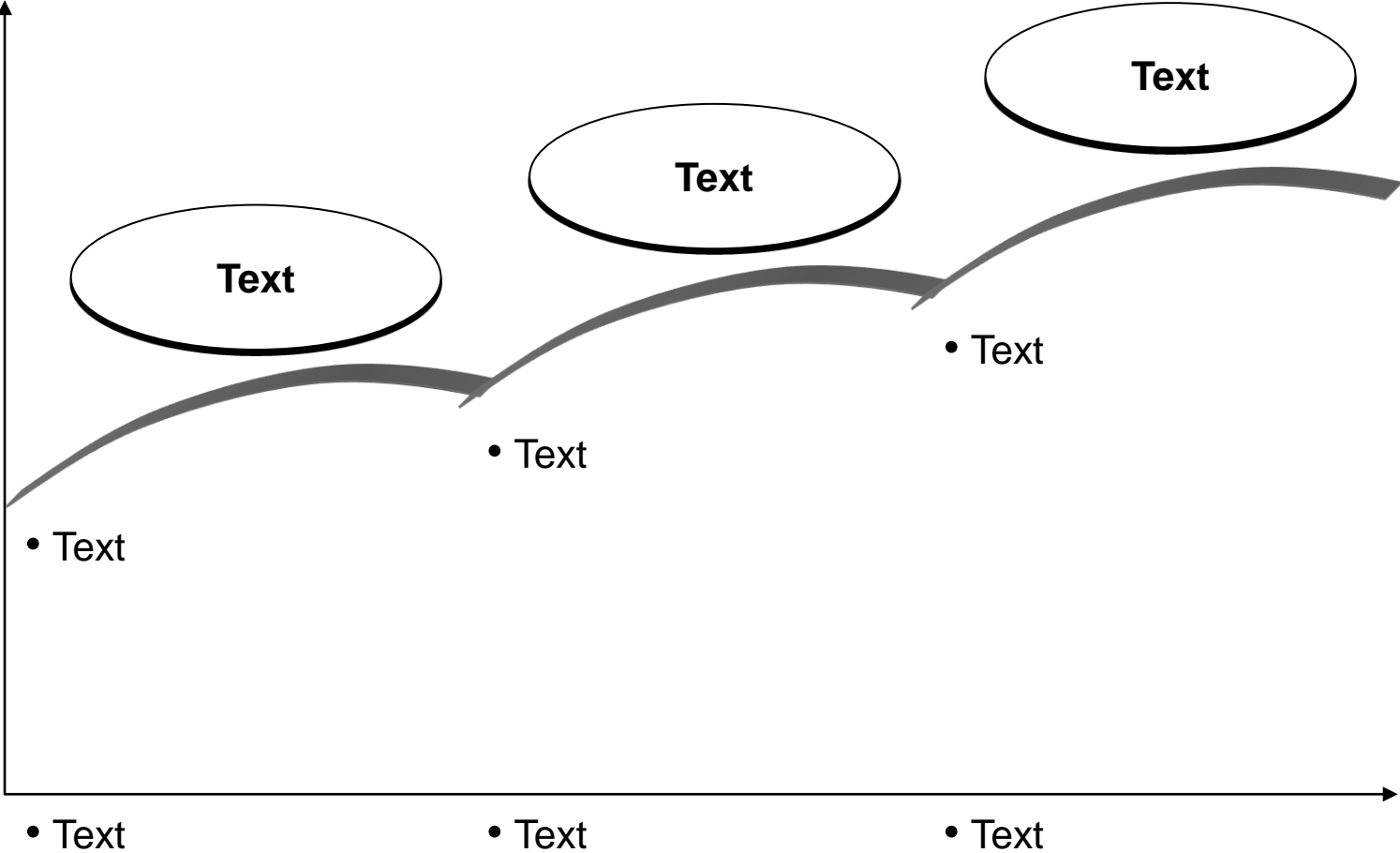

* Footnote

4 HORIZONTAL

Unit of measure

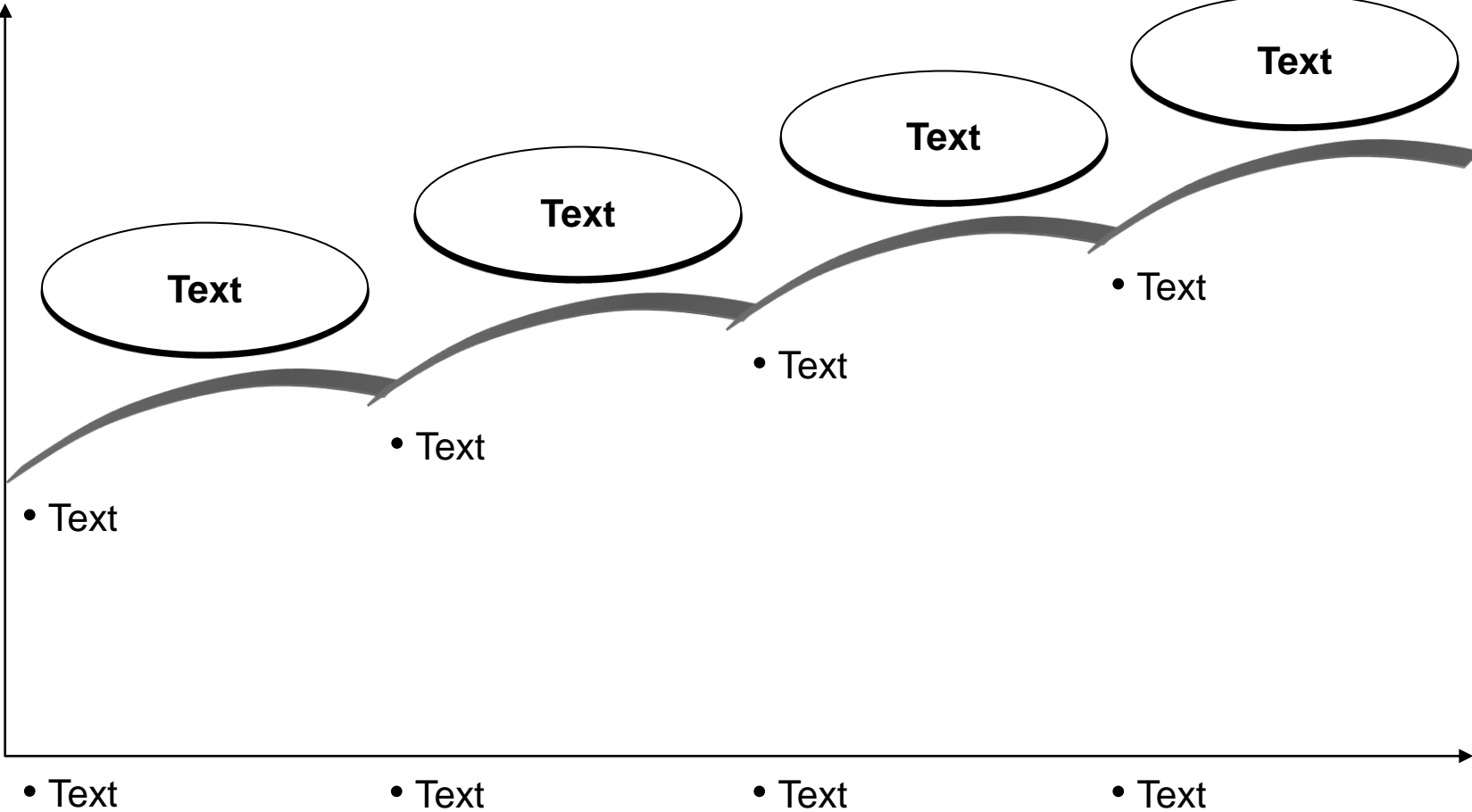

* Footnote

5 HORIZONTAL

Unit of measure

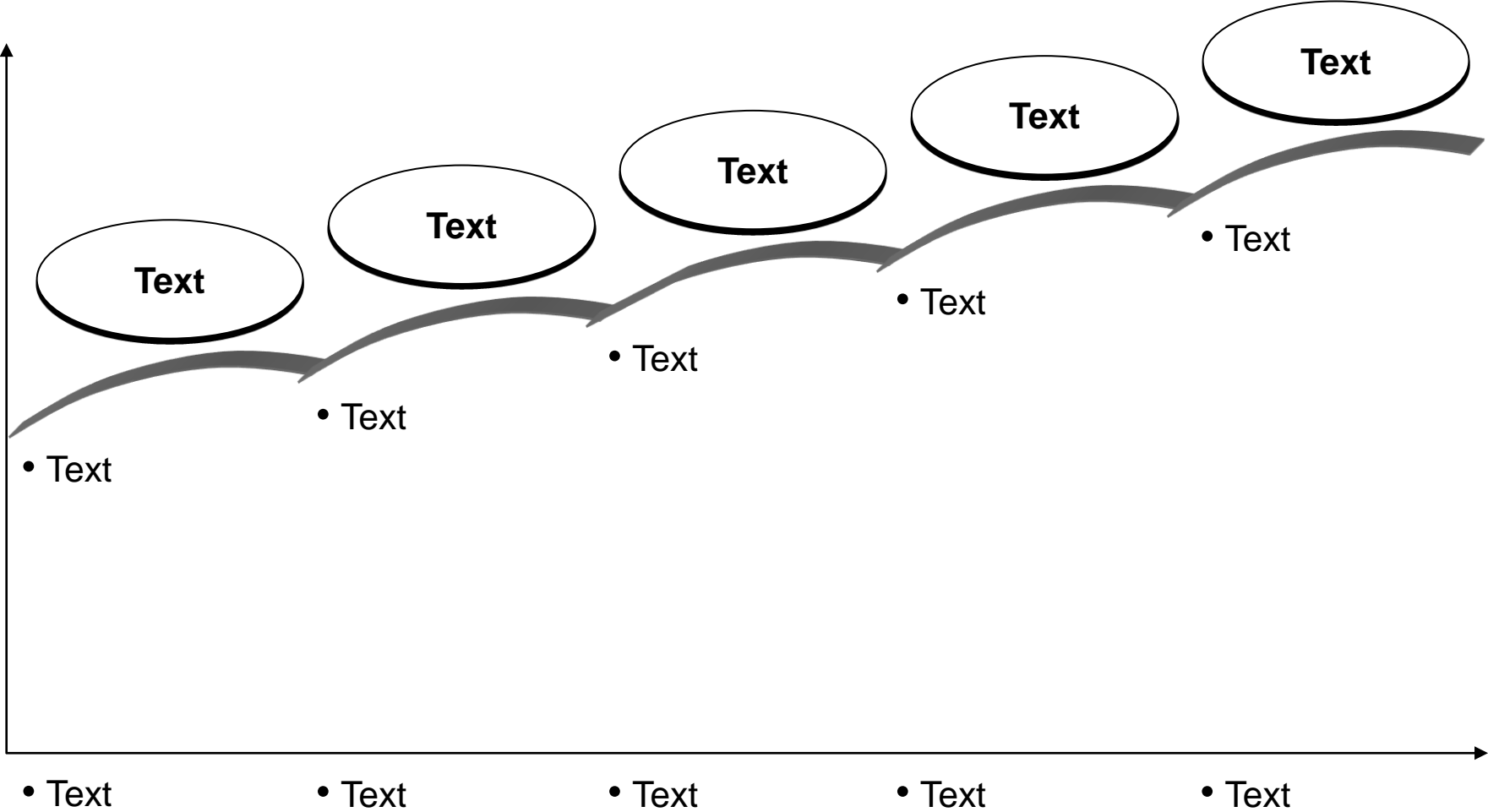

* Footnote

4-STEP

Unit of measure

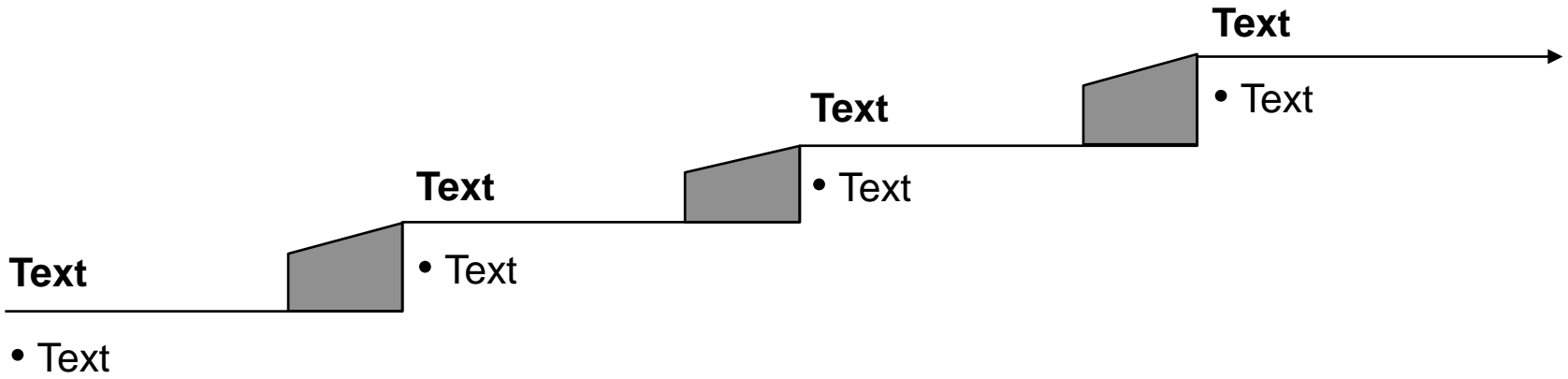

* Footnote

FLOW 2

Unit of measure

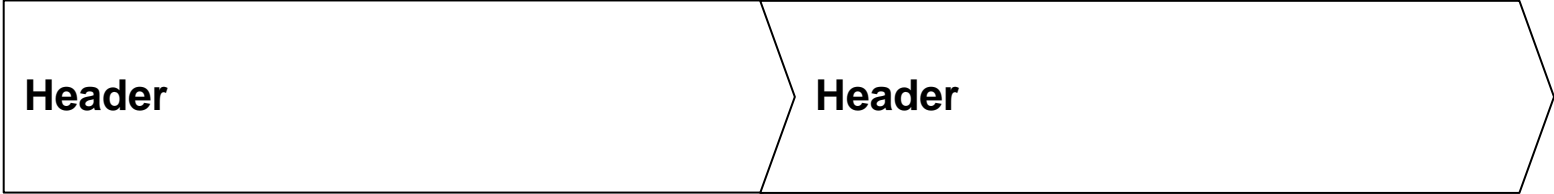

• Text

• Text

* Footnote

FLOW 2 TITLE

Unit of measure

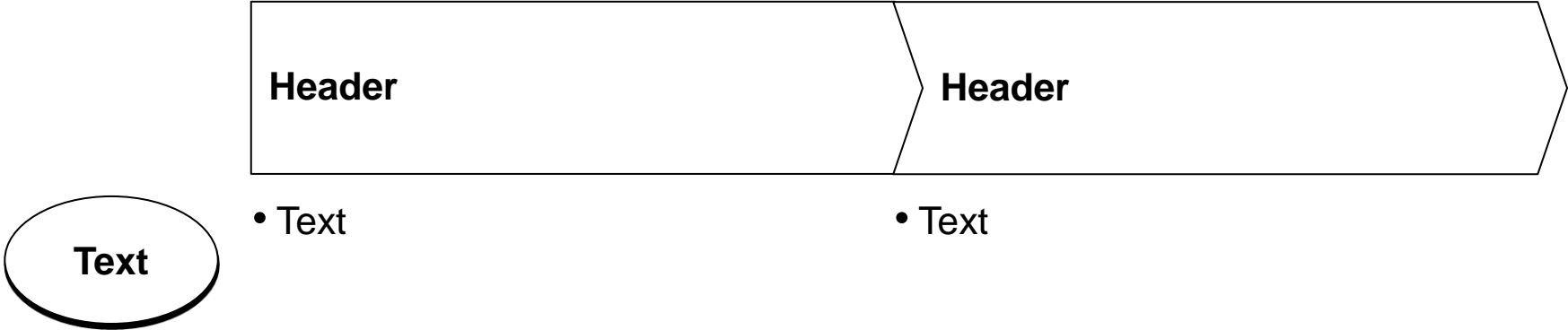

* Footnote

FLOW 3

Unit of measure

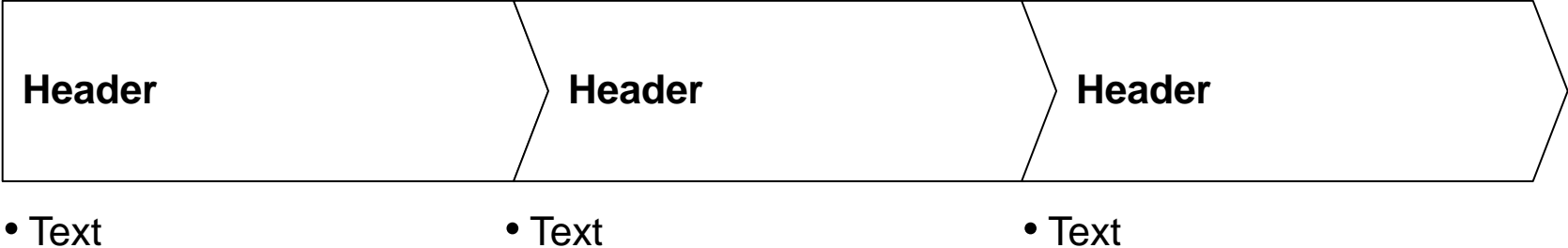

* Footnote

FLOW 3 TITLE

Unit of measure



• Text

• Text

• Text

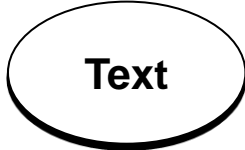

Text

* Footnote

FLOW 4

Unit of measure

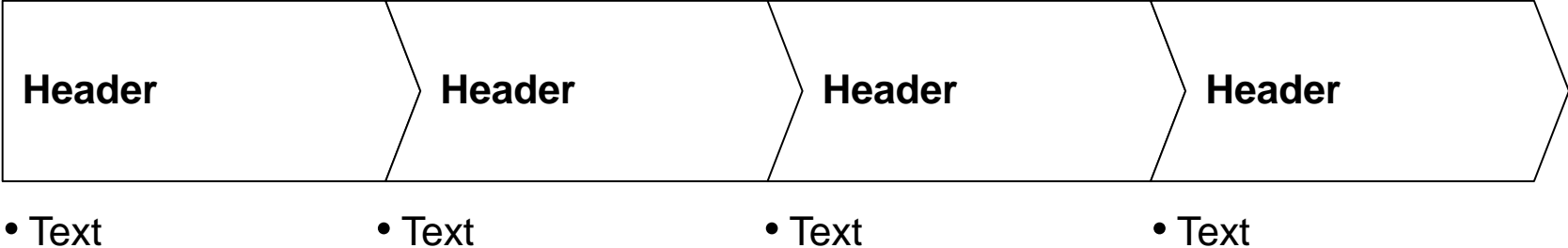

* Footnote

FLOW 4 TITLE

Unit of measure

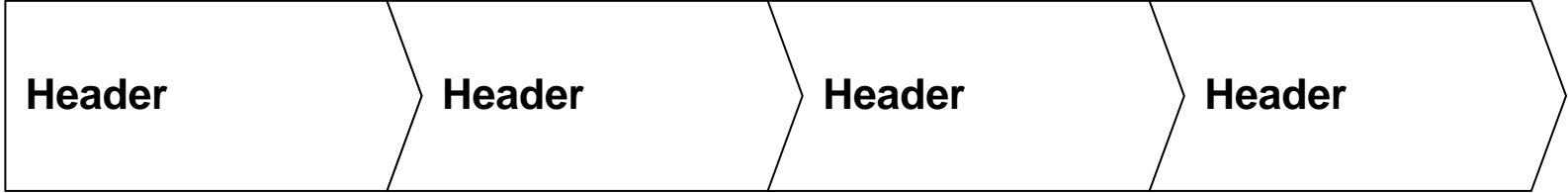

• Text

• Text

• Text

• Text

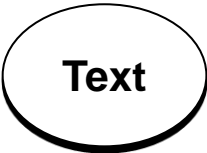

* Footnote

FLOW 5

Unit of measure

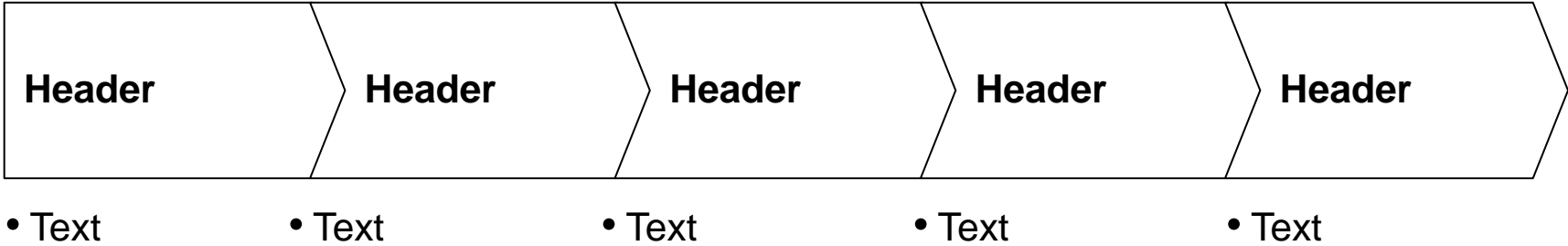

* Footnote

FLOW 5 TITLE

Unit of measure

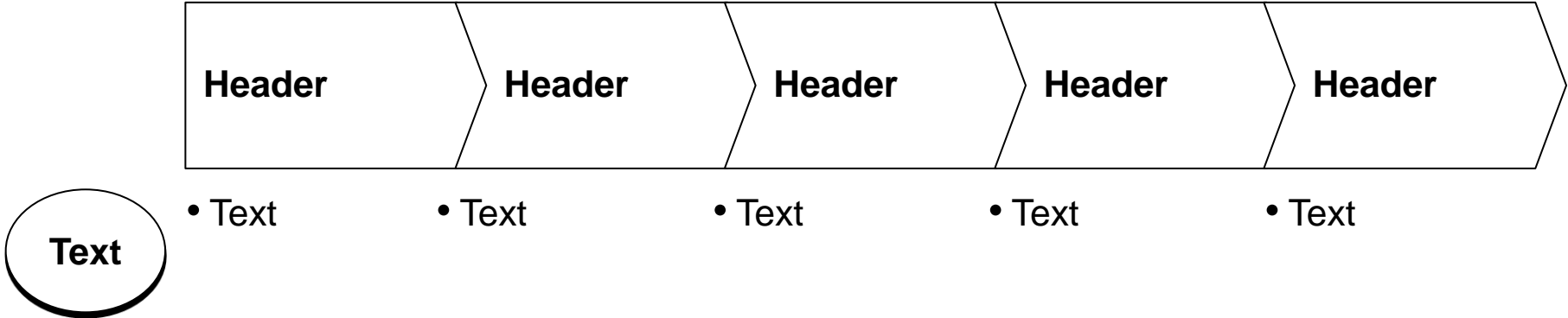

* Footnote

HORIZONTAL FLOW 3

Unit of measure

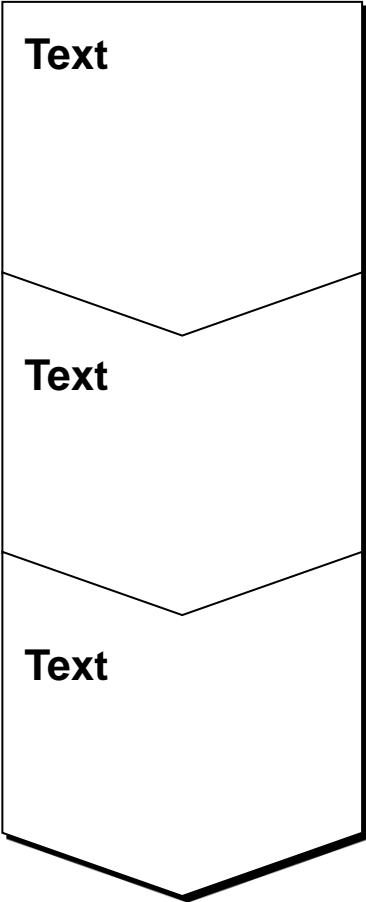

Title

- Text

- Text

- Text

* Footnote

HORIZONTAL FLOW 4

Unit of measure

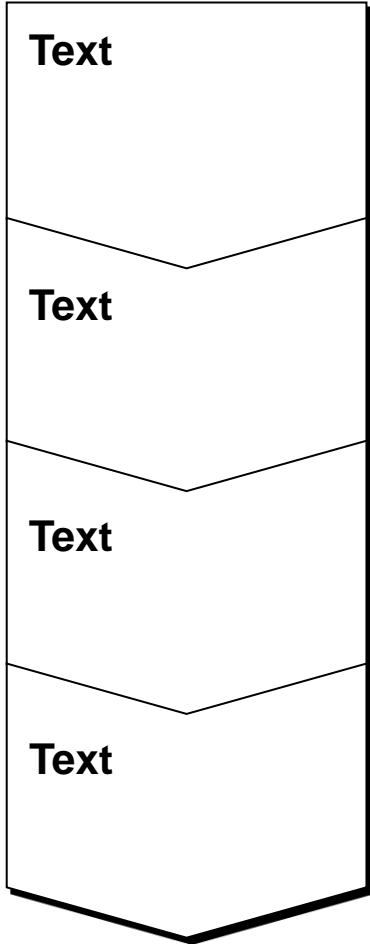

Title

- Text

- Text

- Text

- Text

* Footnote

HORIZONTAL FLOW 5

Unit of measure

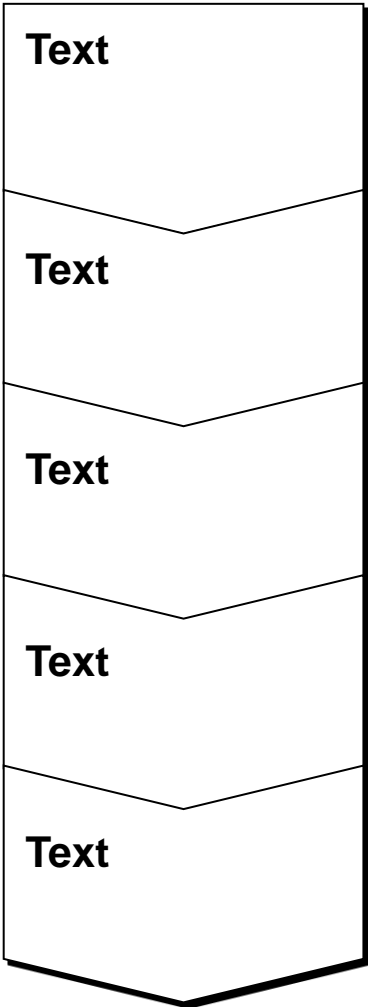

Title

- Text
- Text
- Text
- Text
- Text

Title

- Text
- Text
- Text
- Text
- Text

* Footnote

HORIZONTAL FLOW 6

Unit of measure

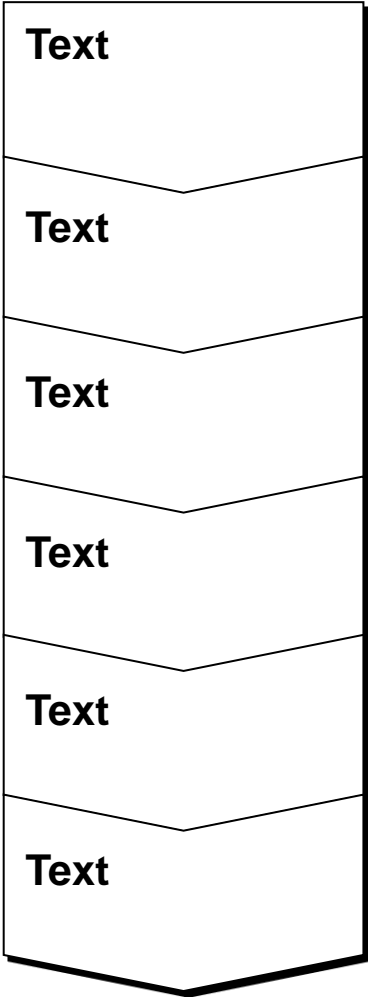

Title

- Text
- Text
- Text
- Text
- Text
- Text

Title

- Text
- Text
- Text
- Text
- Text
- Text

* Footnote

HORIZONTAL FLOW 7

Unit of measure

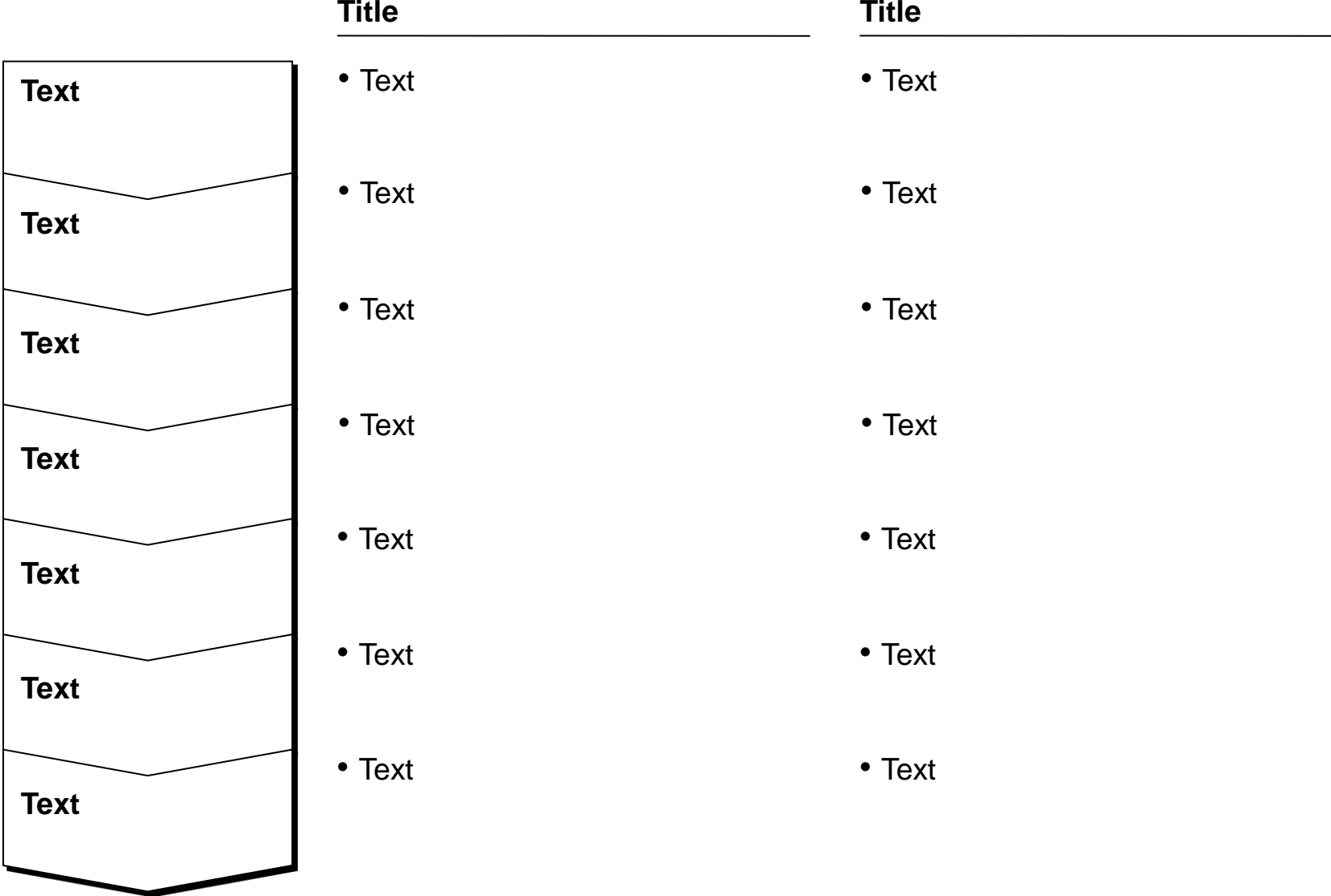

* Footnote

FLOW WITH SHOCK 1

Unit of measure

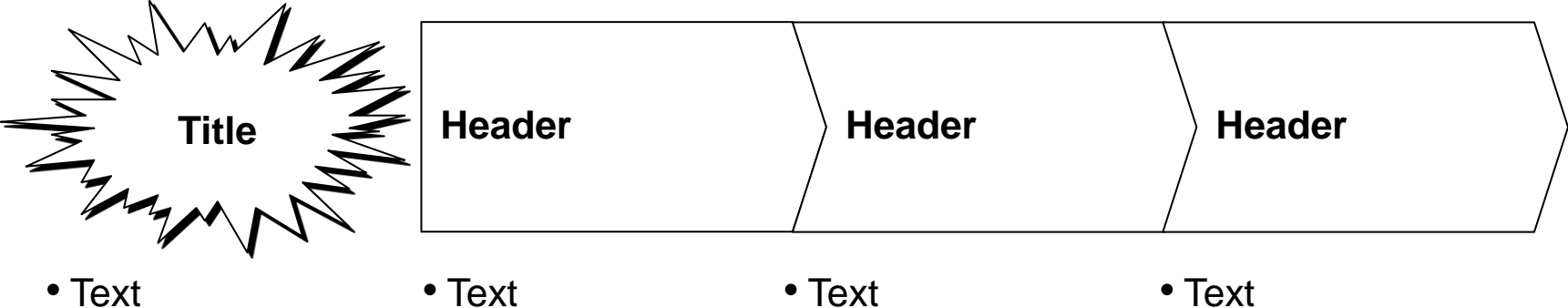

* Footnote

FLOW WITH SHOCK 2

Unit of measure

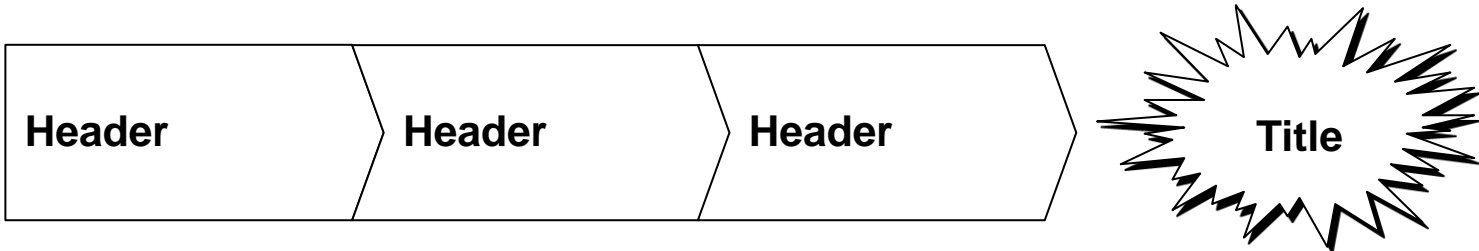

Text

• Text

• Text

• Text

• Text

Text

• Text

• Text

• Text

• Text

* Footnote

FLOW WITH 3 COLUMN

Text

Text

Text

Text

• Text

• Text

• Text

Text

• Text

• Text

• Text

Text

• Text

• Text

• Text

Text

• Text

• Text

• Text

Text

• Text

• Text

• Text

* Footnote

FLOW WITH 2 COLUMN

Text

Text

- Text

- Text

- Text

- Text

- Text

- Text

- Text

- Text

- Text

- Text

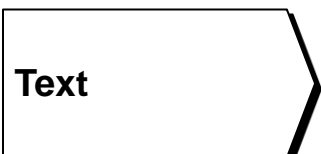

Text

* Footnote

SQUARE FLOW

Unit of measure

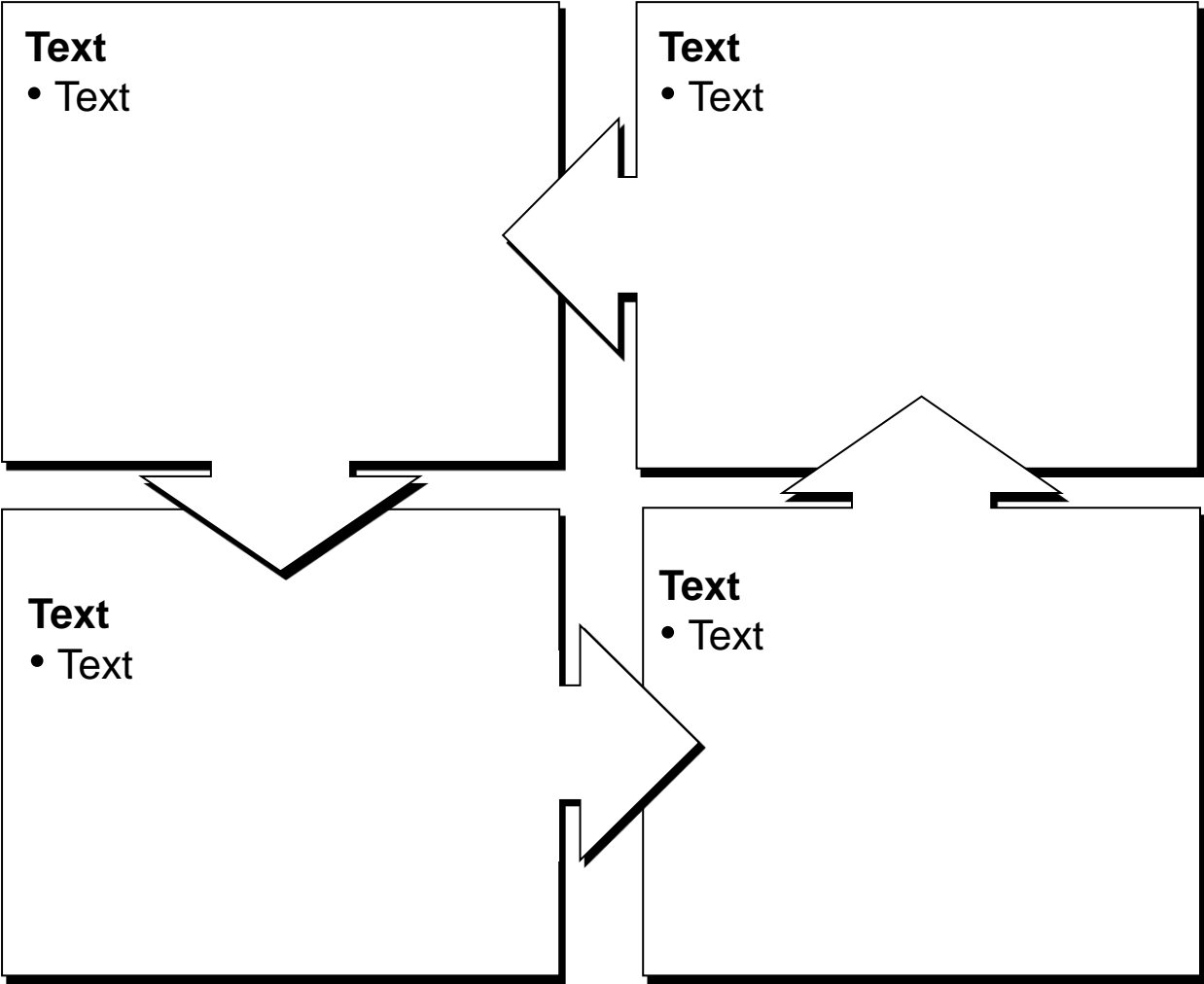

* Footnote

FRAMEWORK

Unit of measure

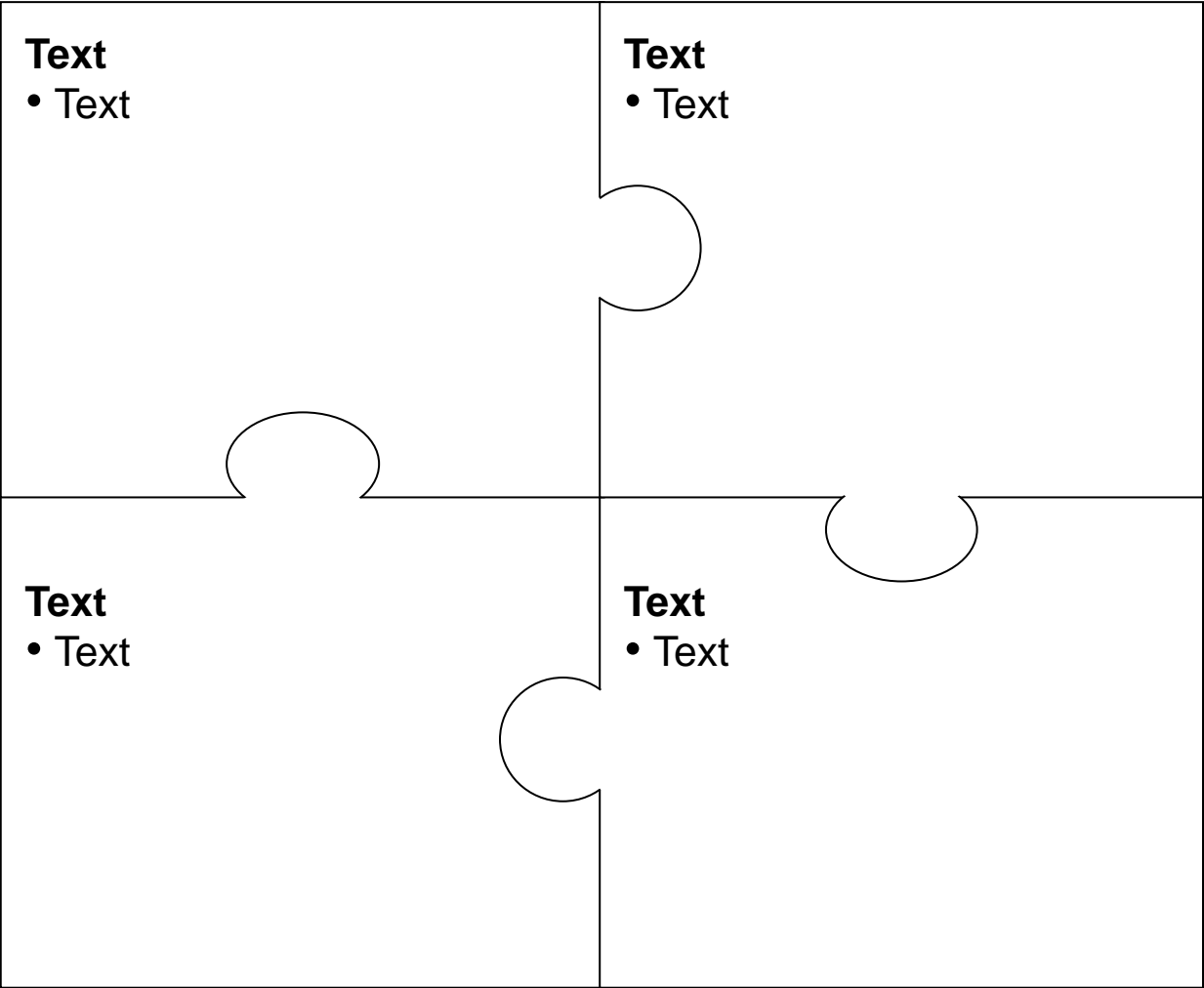

* Footnote

Unit of measure

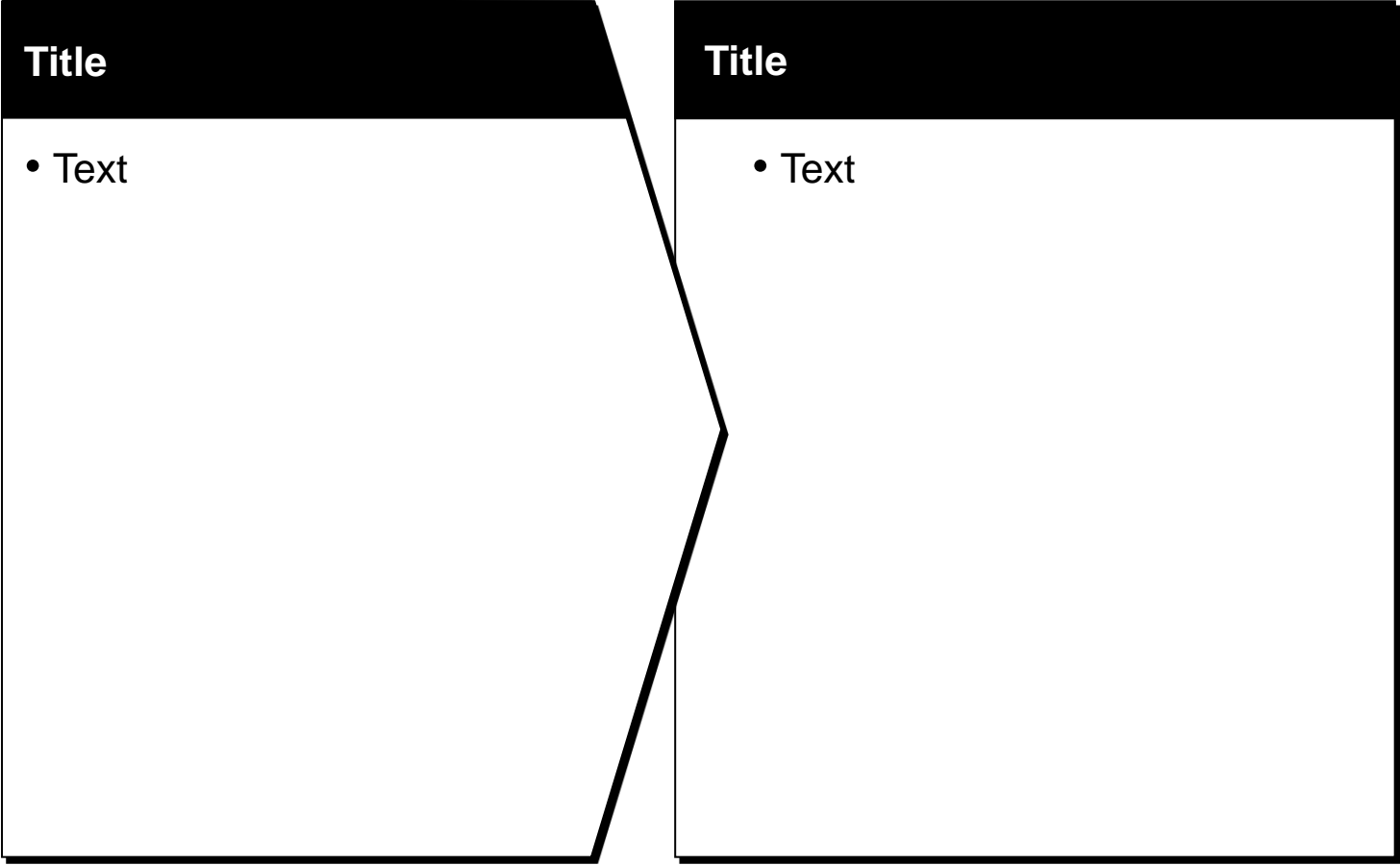

* Footnote

Unit of measure

Title

- Text

Title

- Text

* Footnote

Unit of measure

Title

- Text

Title

- Text

Title

- Text

Title

- Text

* Footnote

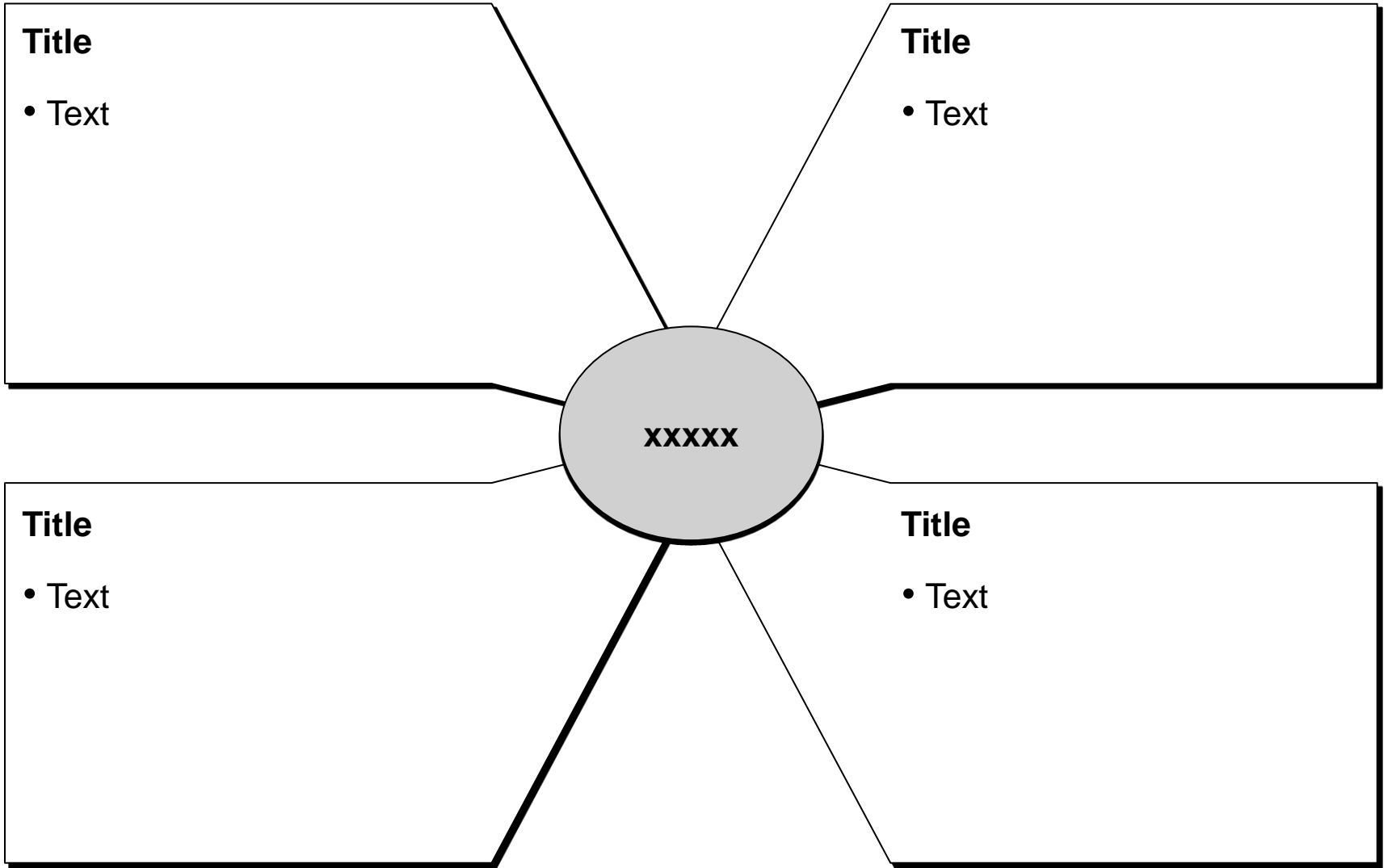

Unit of measure

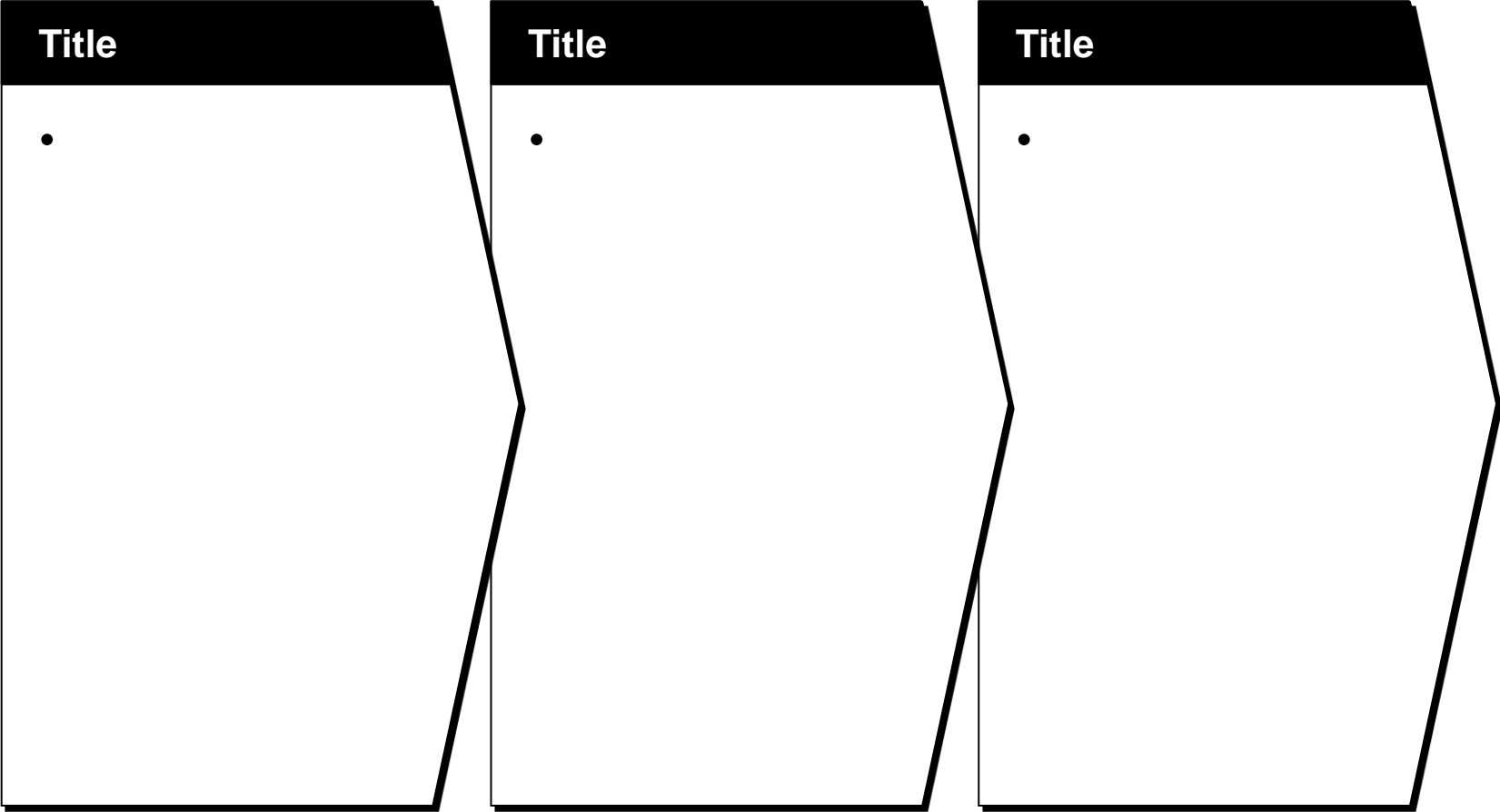

* Footnote

Unit of measure

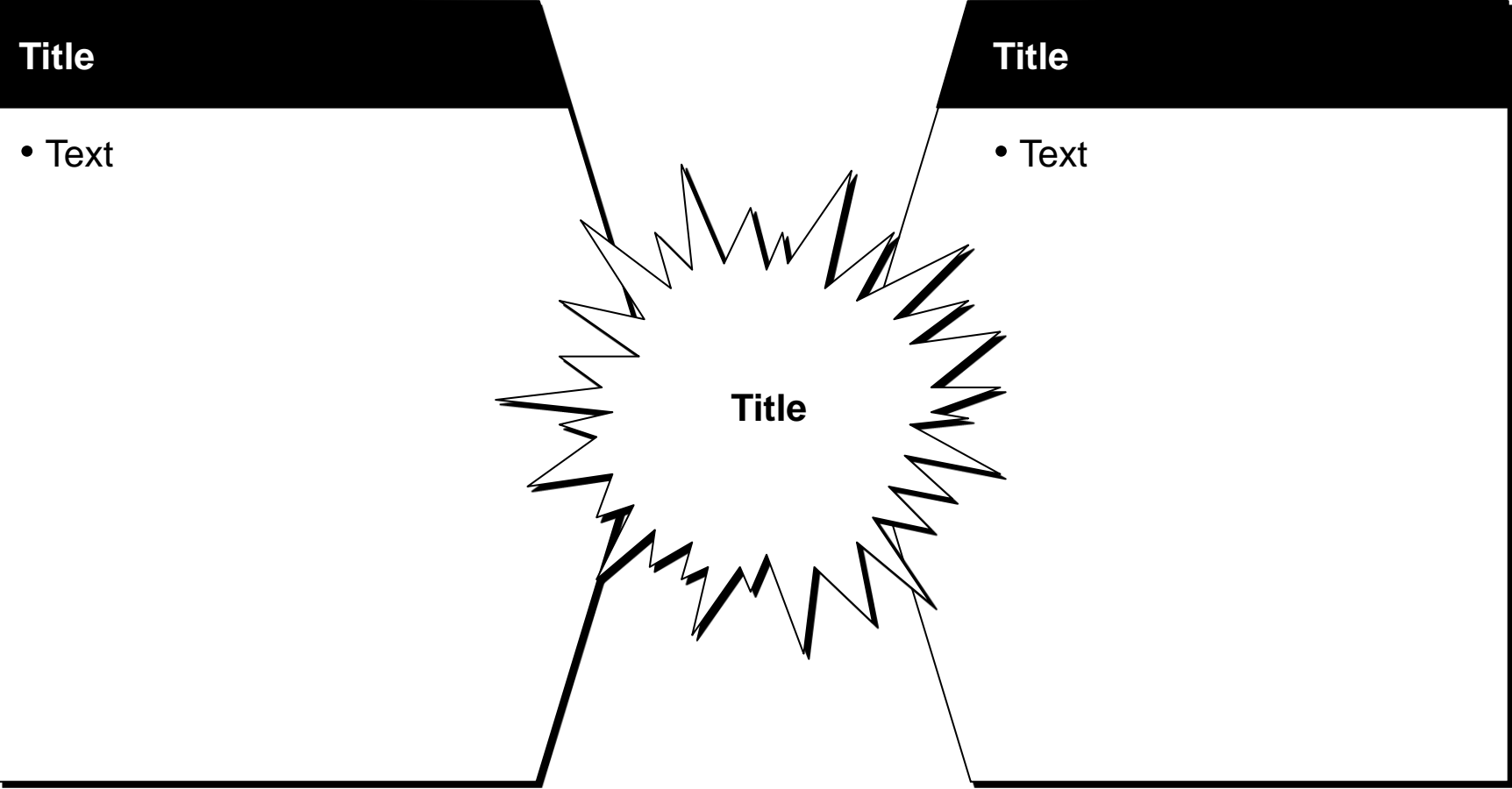

* Footnote

Unit of measure

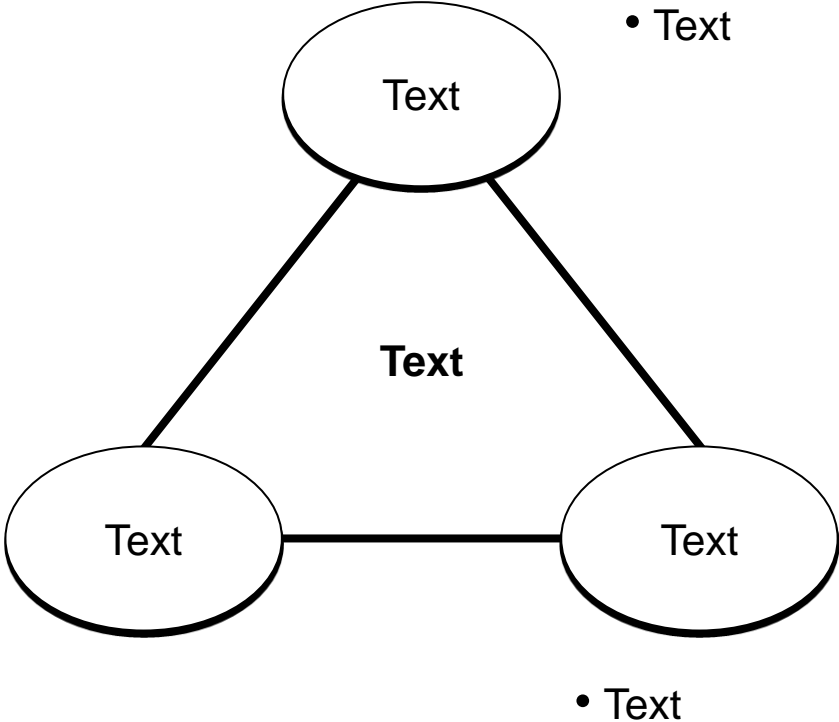

* Footnote

Unit of measure

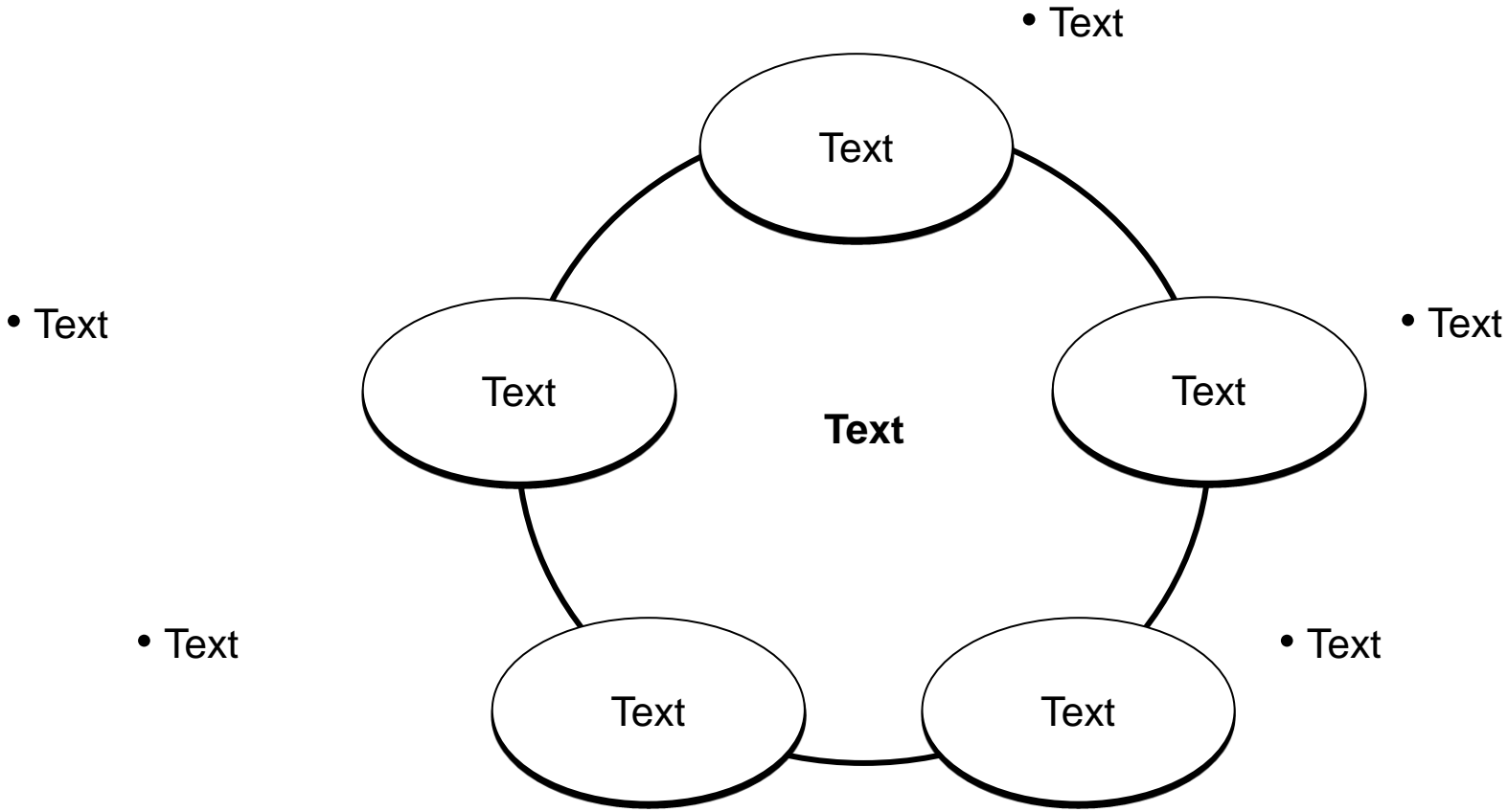

* Footnote

SCP

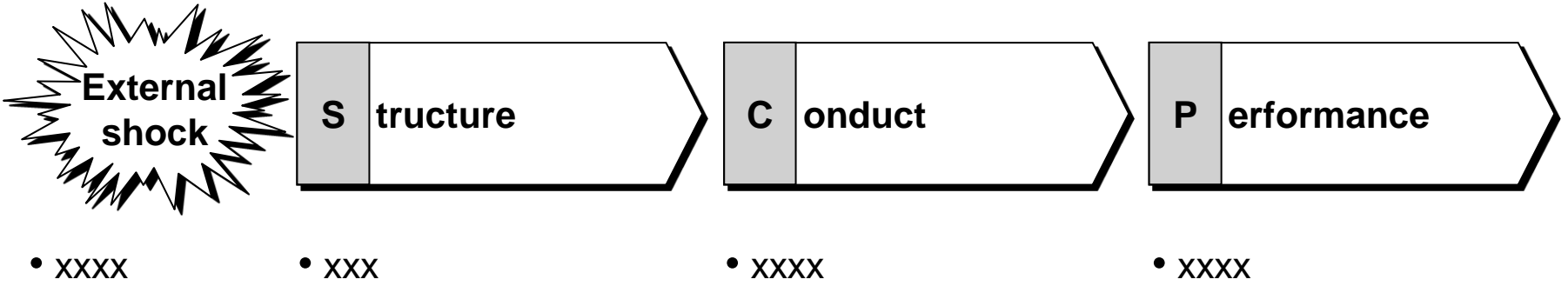

* Footnote

Unit of measure

Text

Text

Text

Text

• Text

• Text

• Text

• Text

Text

• Text

• Text

• Text

• Text

Text

* Footnote

Unit of measure

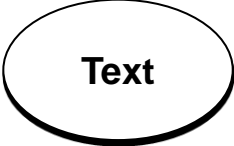
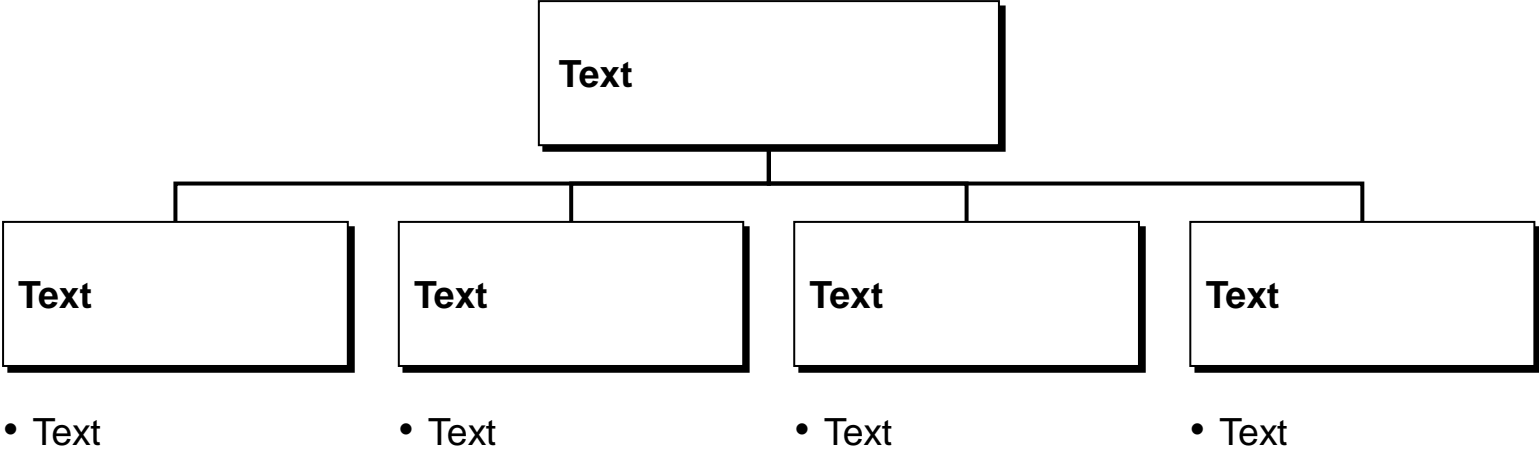

• Text

• Text

• Text

• Text

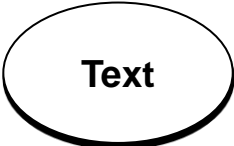

• Text

• Text

• Text

• Text

* Footnote

Unit of measure

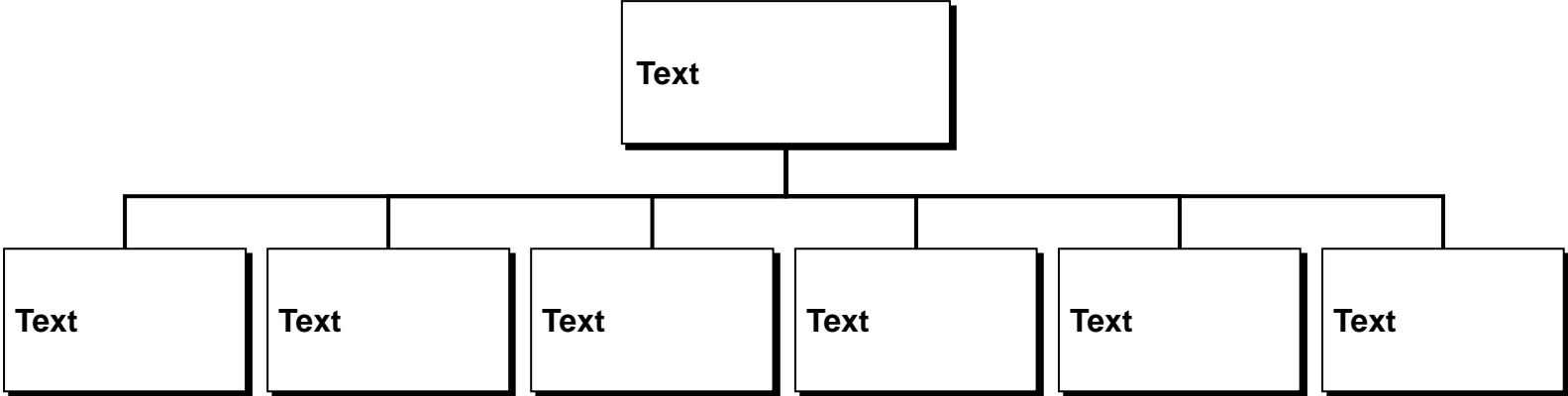

- Text
- Text
- Text
- Text
- Text
- Text

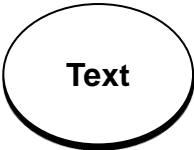

- Text
- Text
- Text
- Text
- Text
- Text

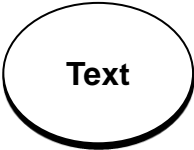

* Footnote

Unit of measure

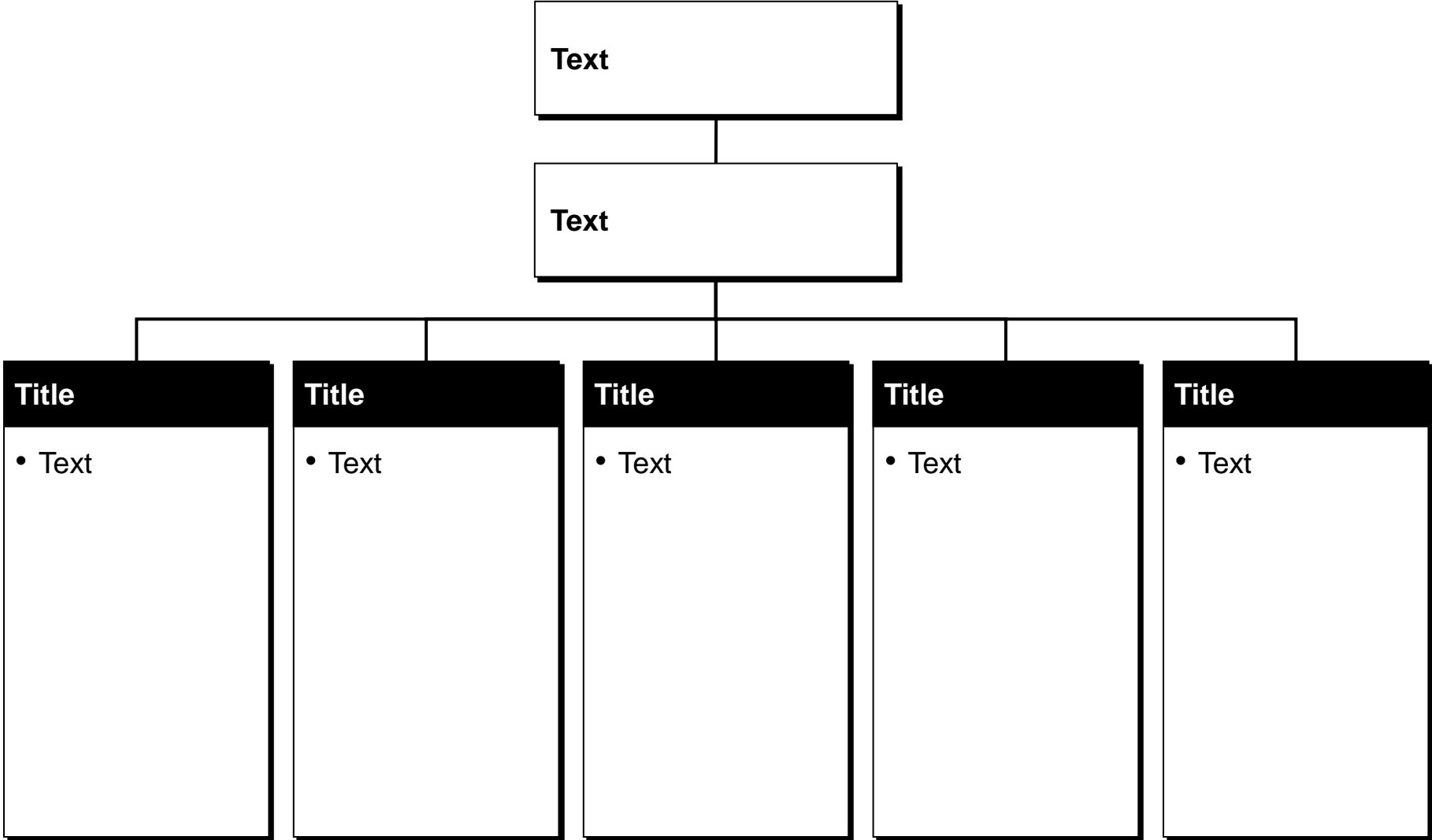

* Footnote

Unit of measure

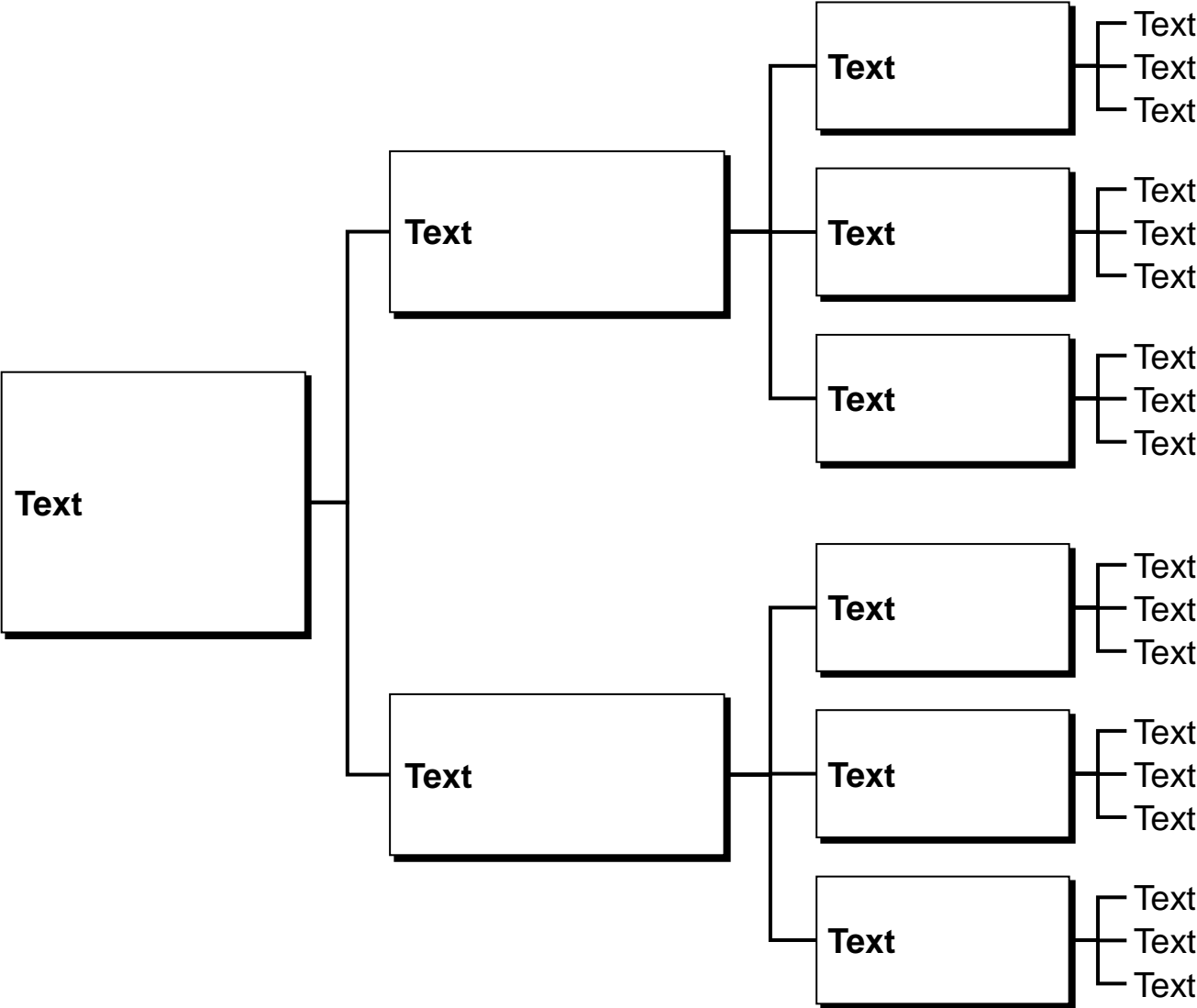

* Footnote

Unit of measure

Title

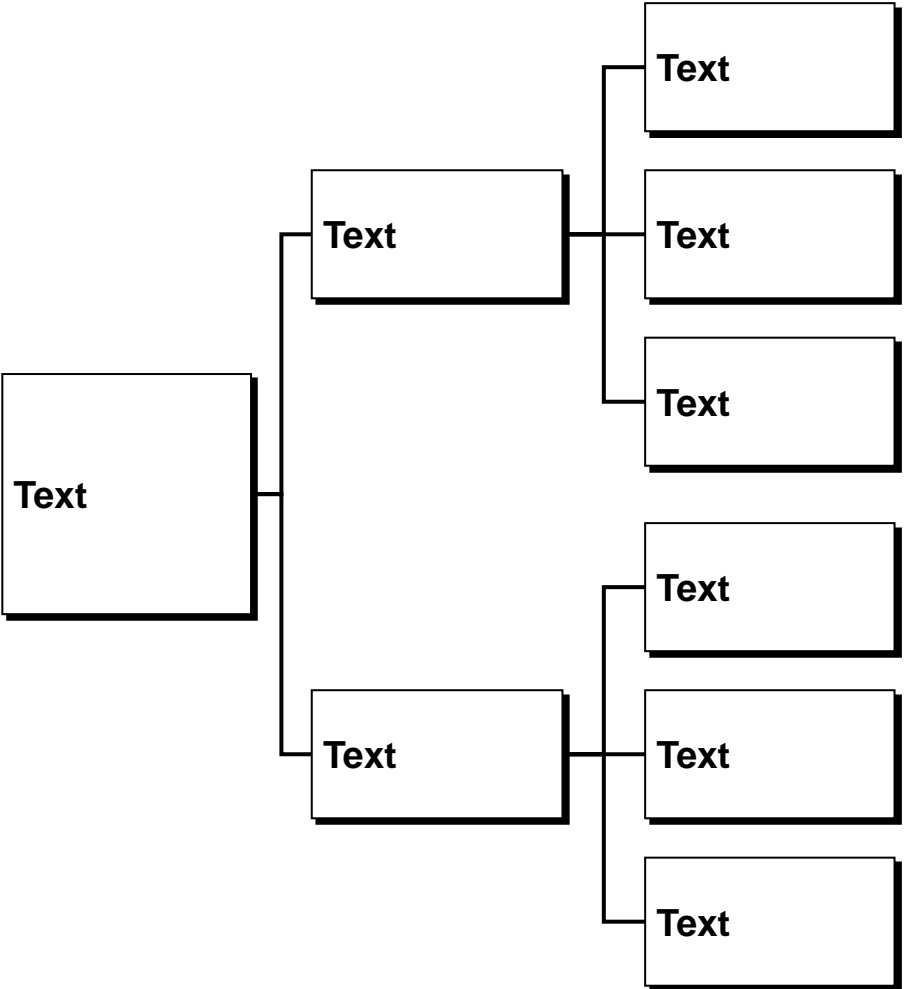

-
-
-
-
-
-

* Footnote

Title

Title

Title

Title

Text

Text

Text

Text



• Text

• Text

• Text

• Text

• Text

• Text

* Footnote

TEAM STRUCTURE

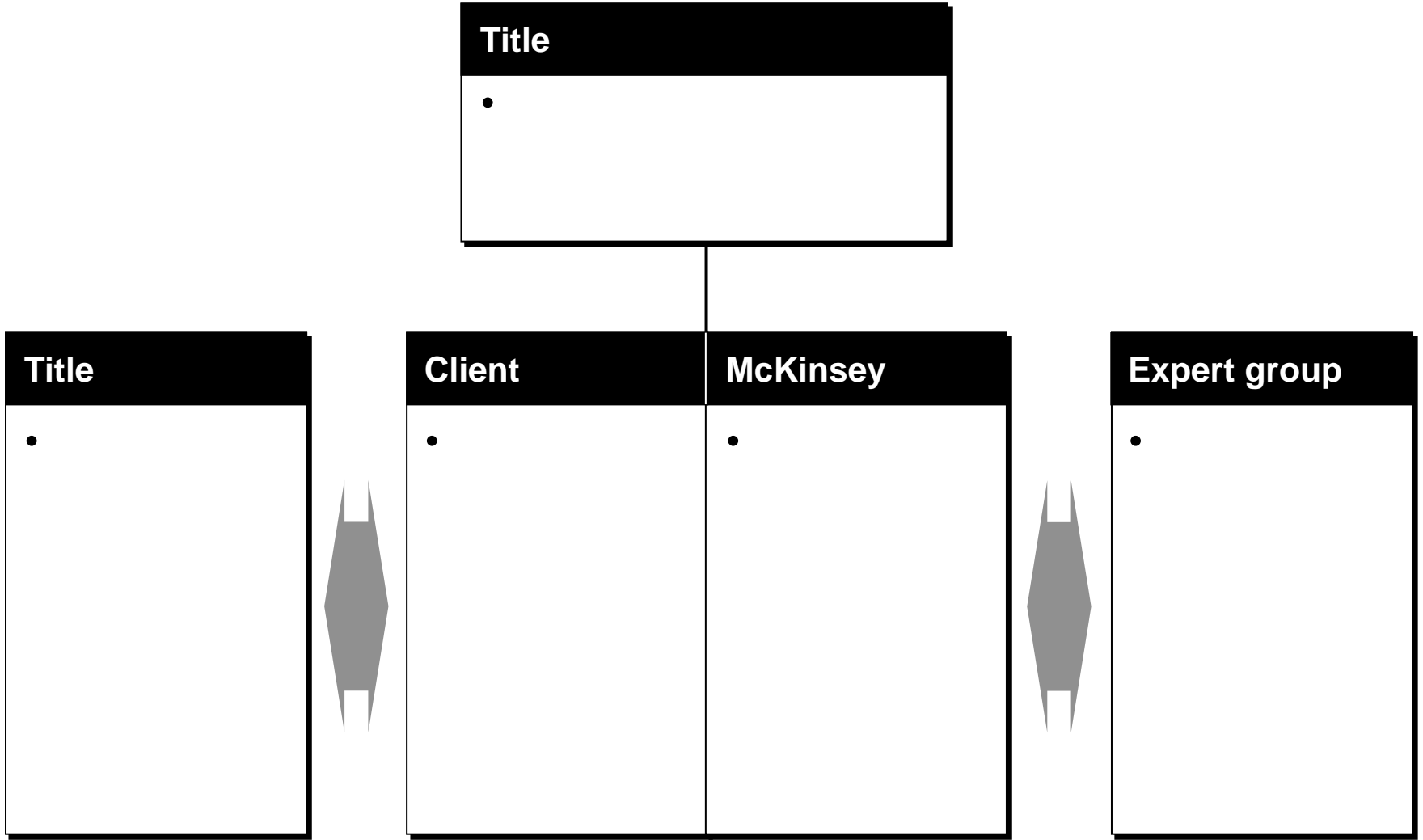

* Footnote

Unit of measure

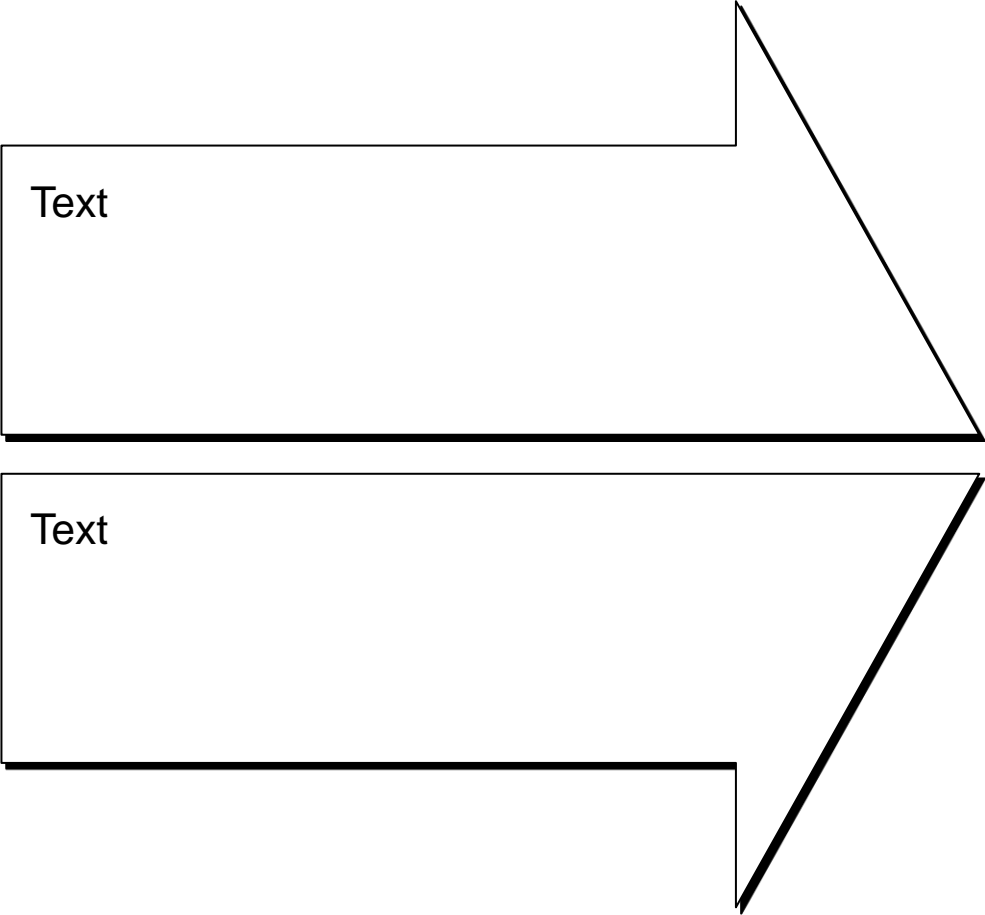

* Footnote

Unit of measure

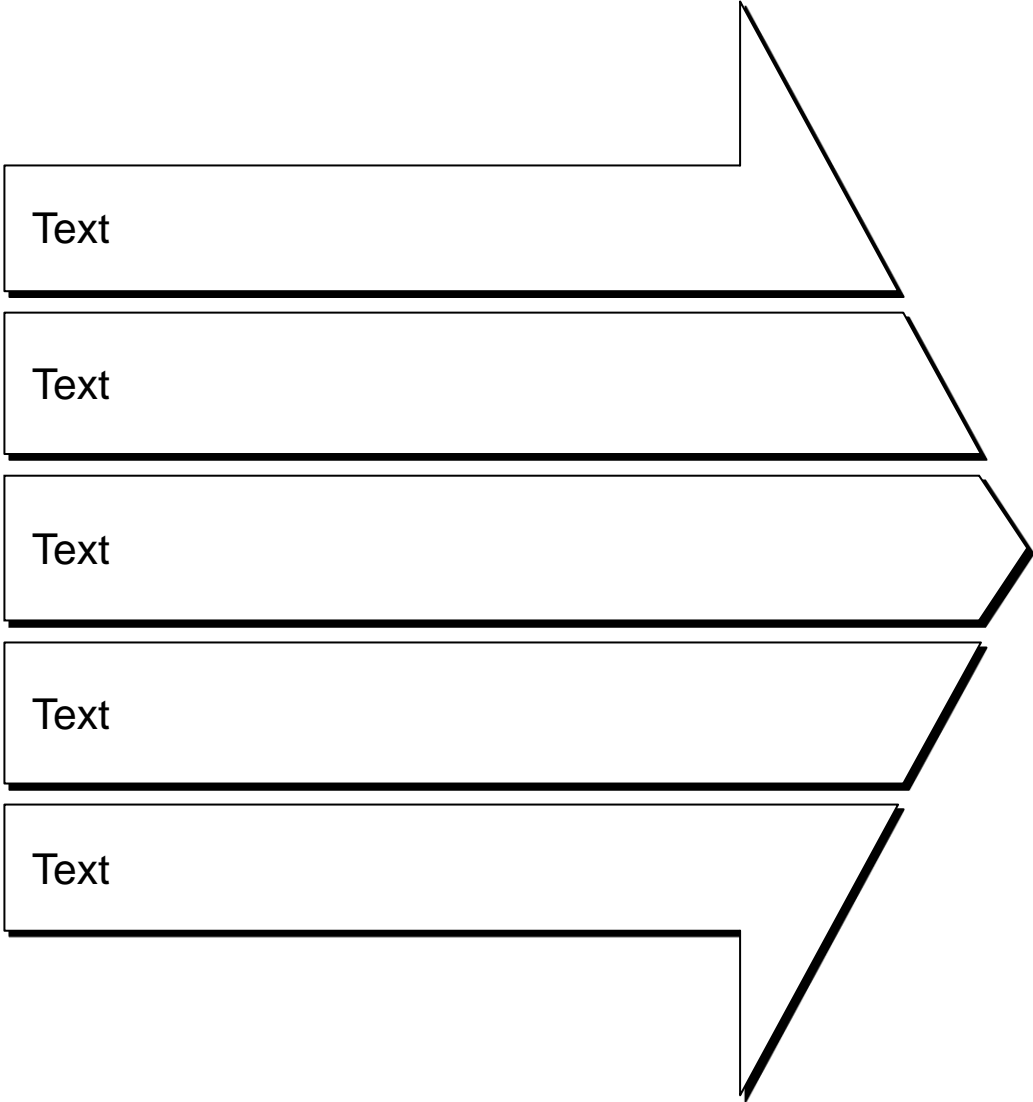

* Footnote

Unit of measure

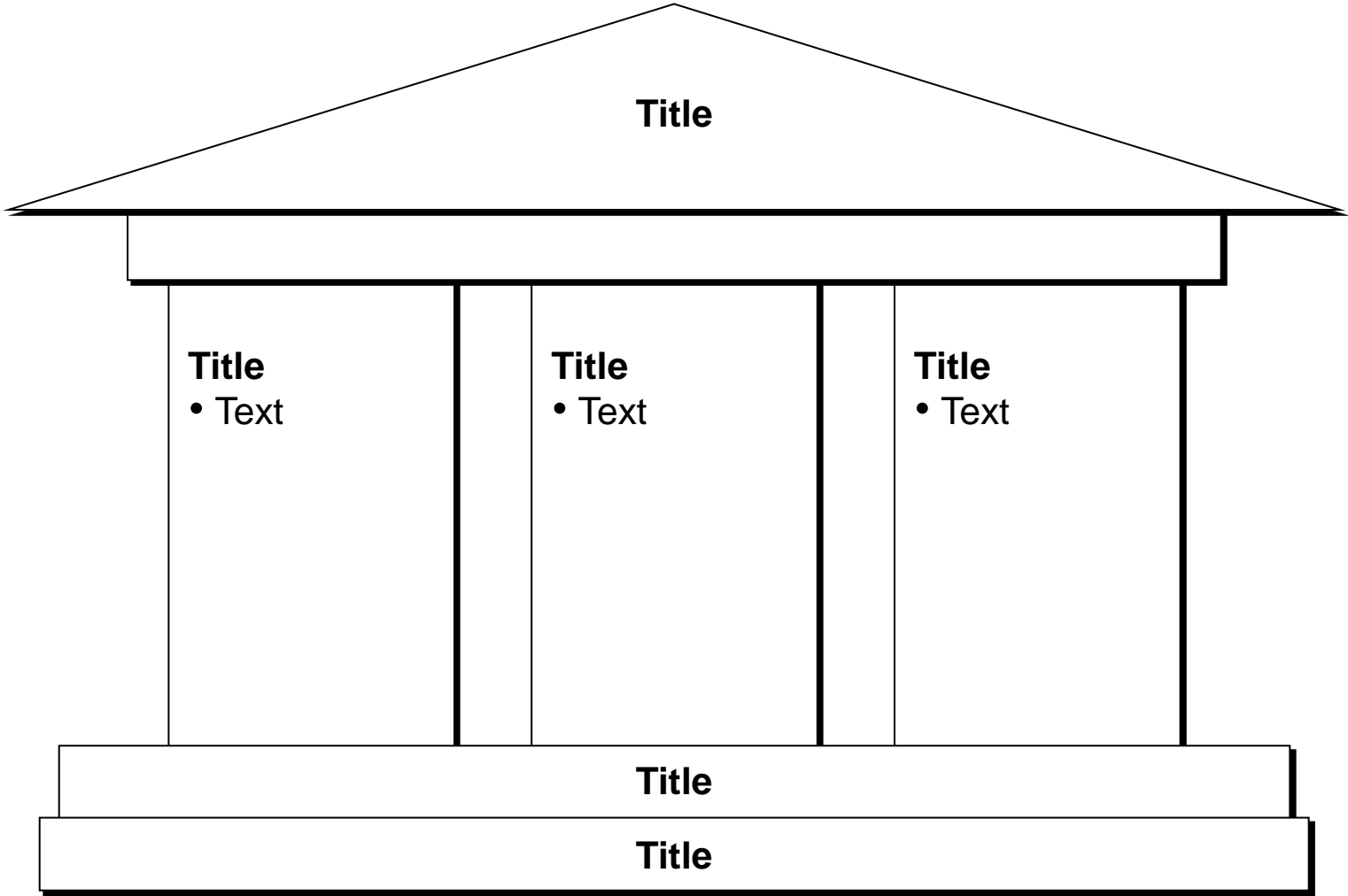

* Footnote

Unit of measure

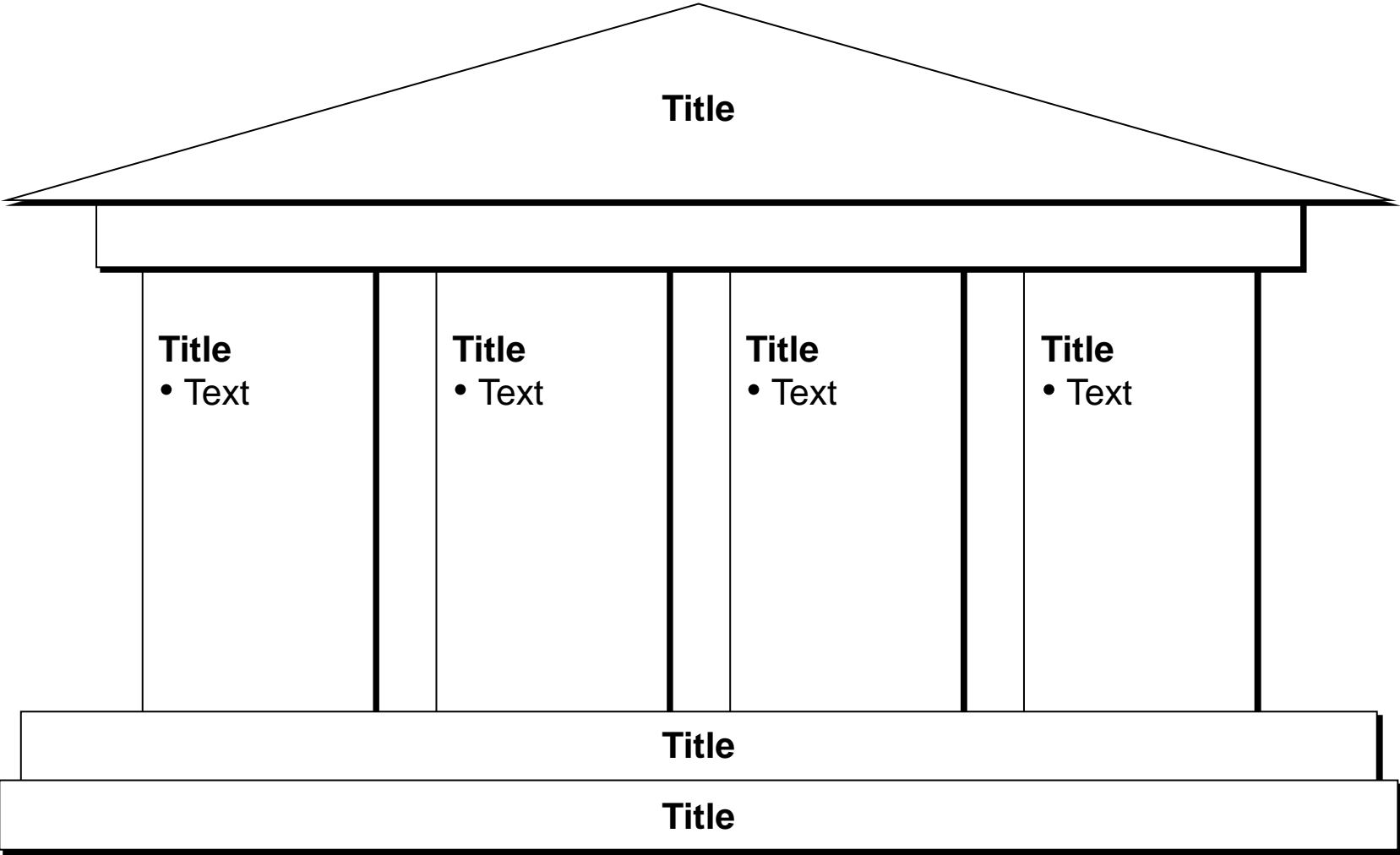

* Footnote

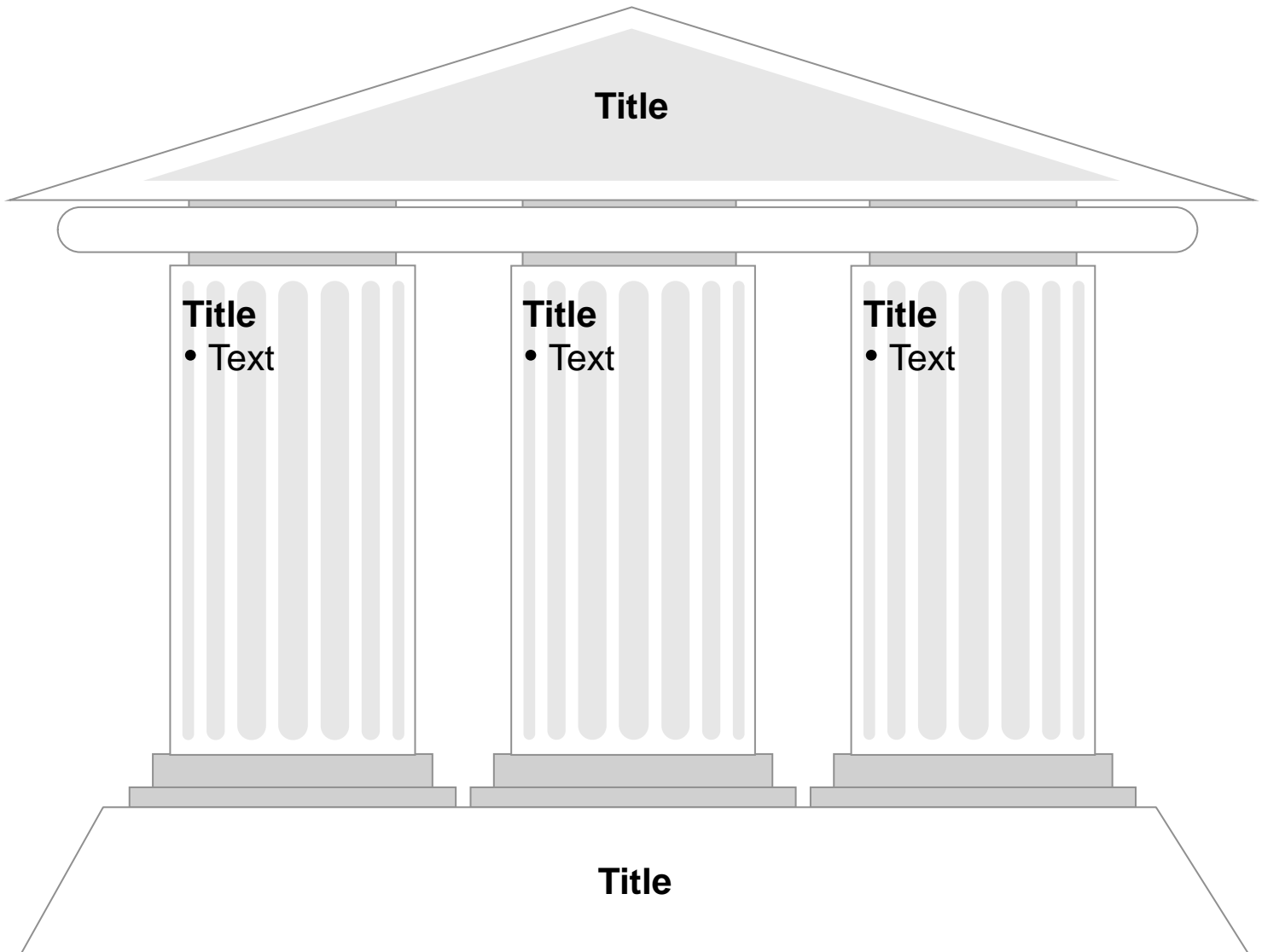

Unit of measure

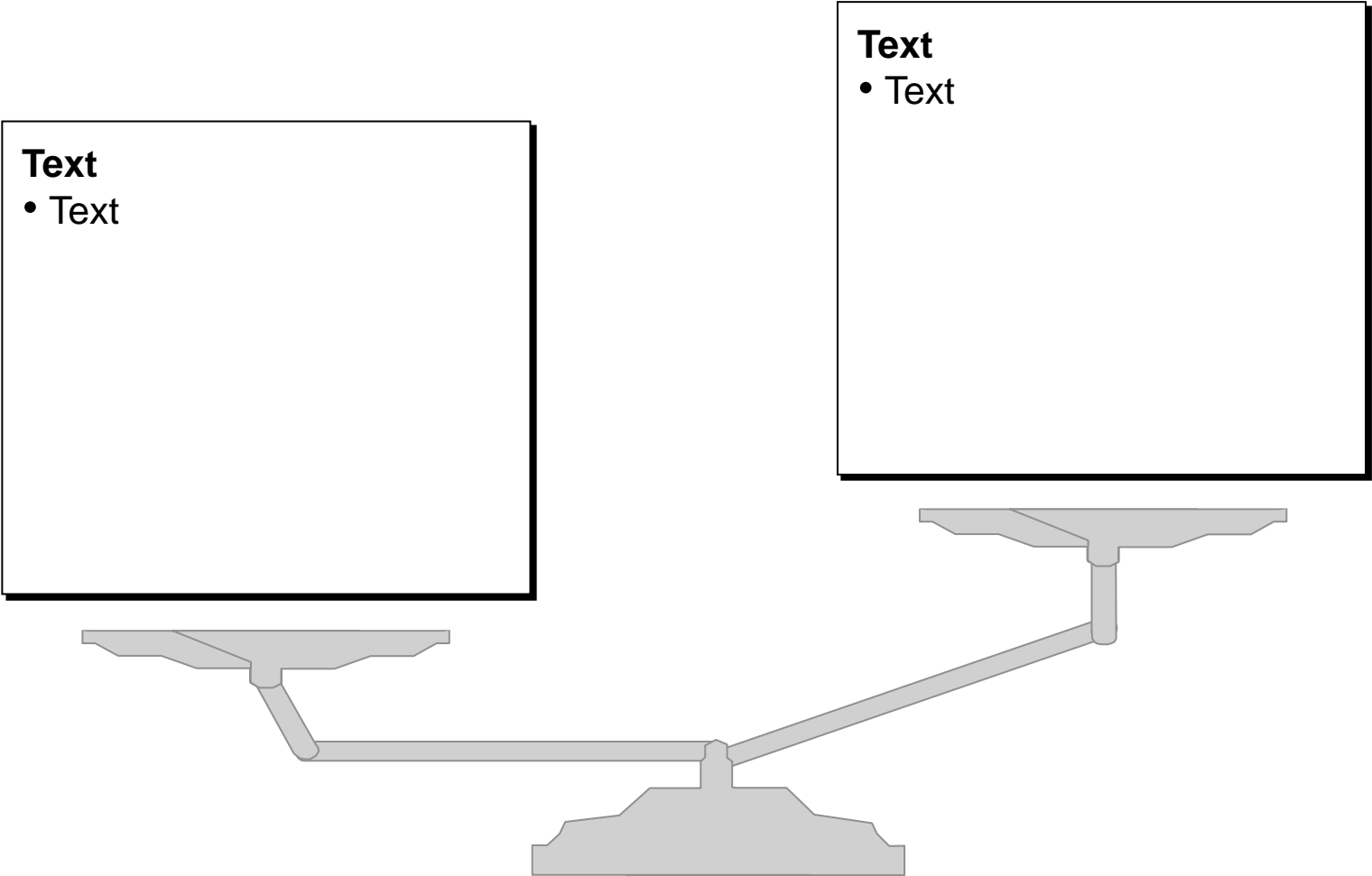

* Footnote

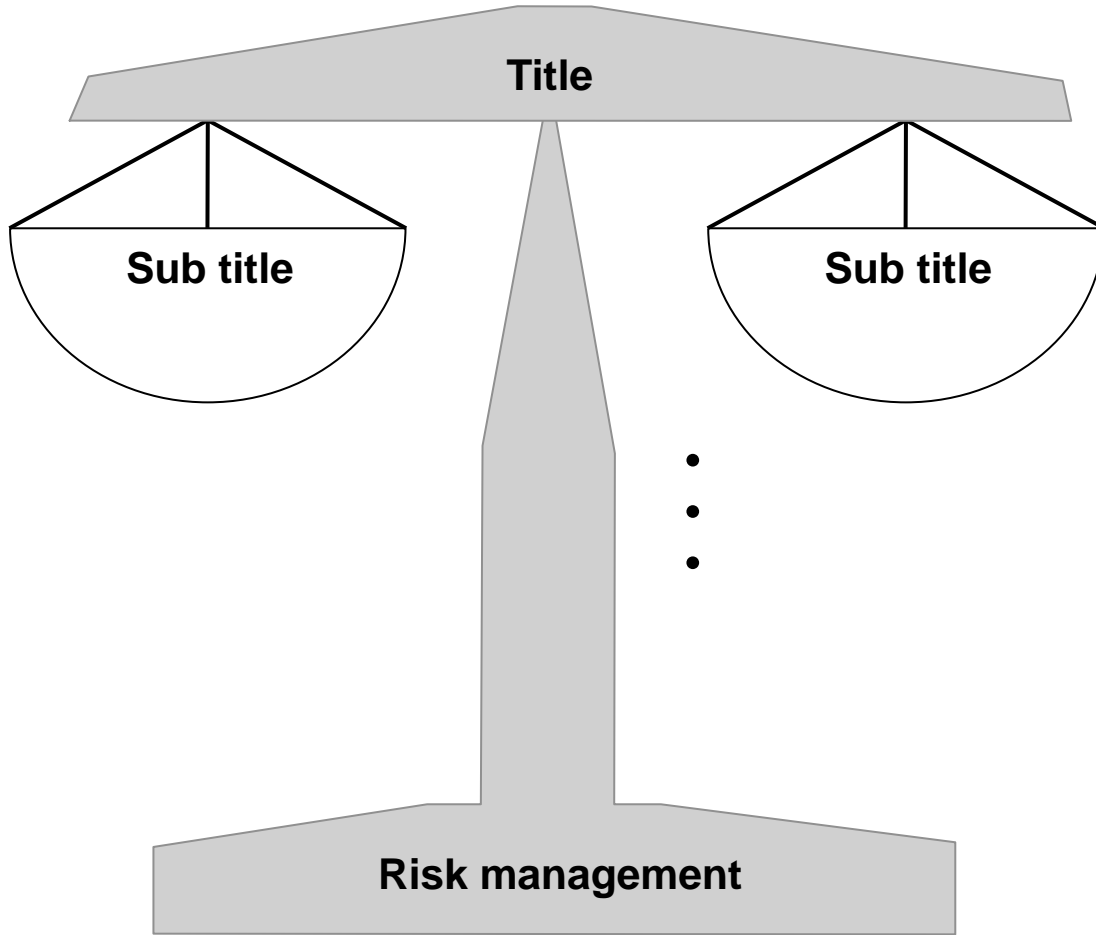

Unit of measure

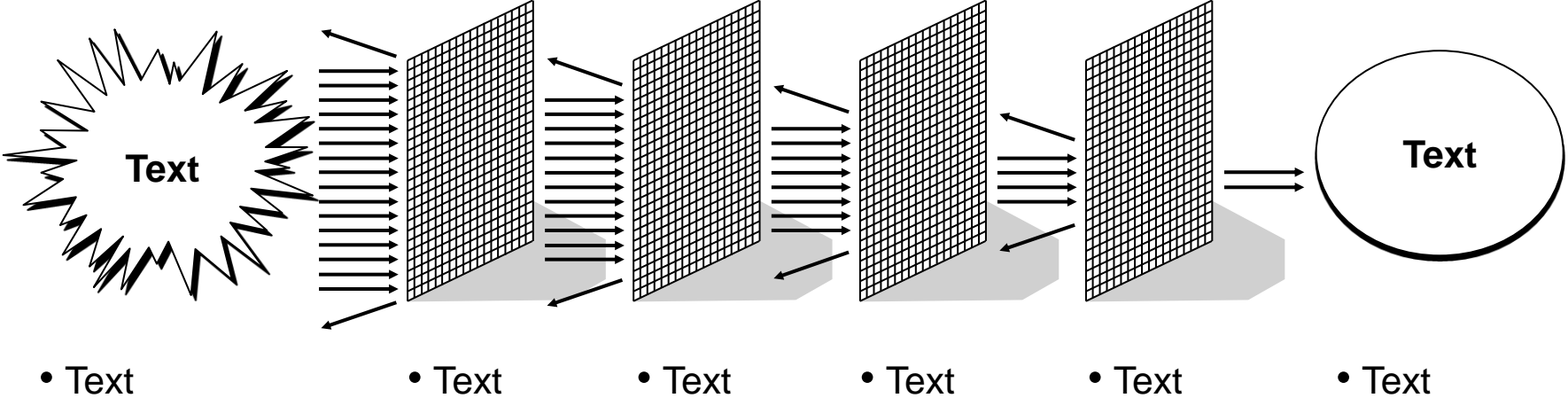

* Footnote

CYCLE 2

Unit of measure

• Text

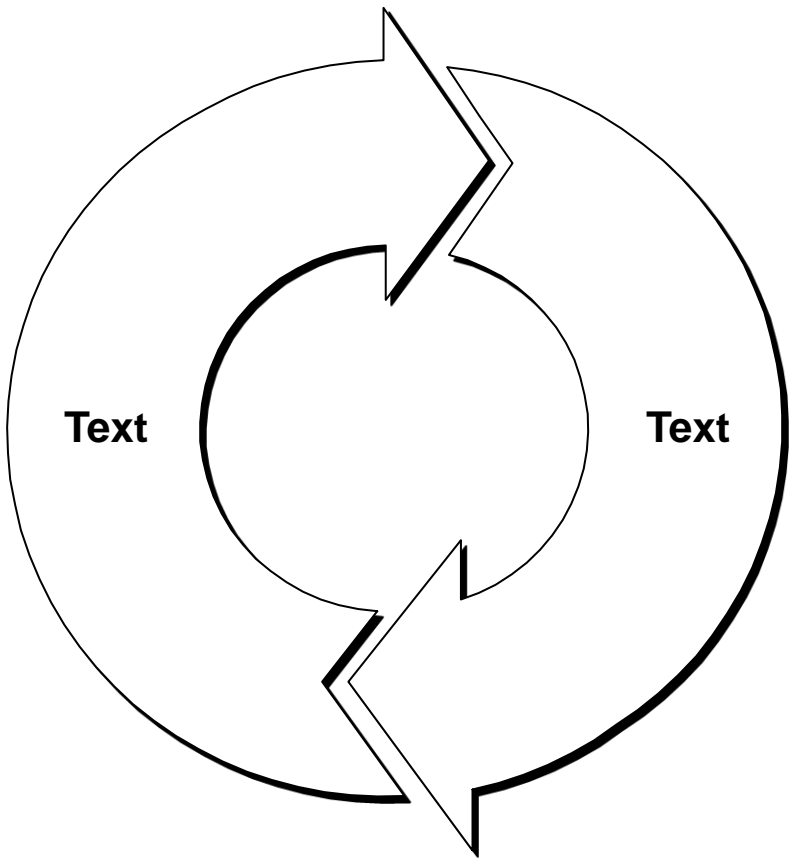

• Text

* Footnote

CYCLE 2

Unit of measure

• Text

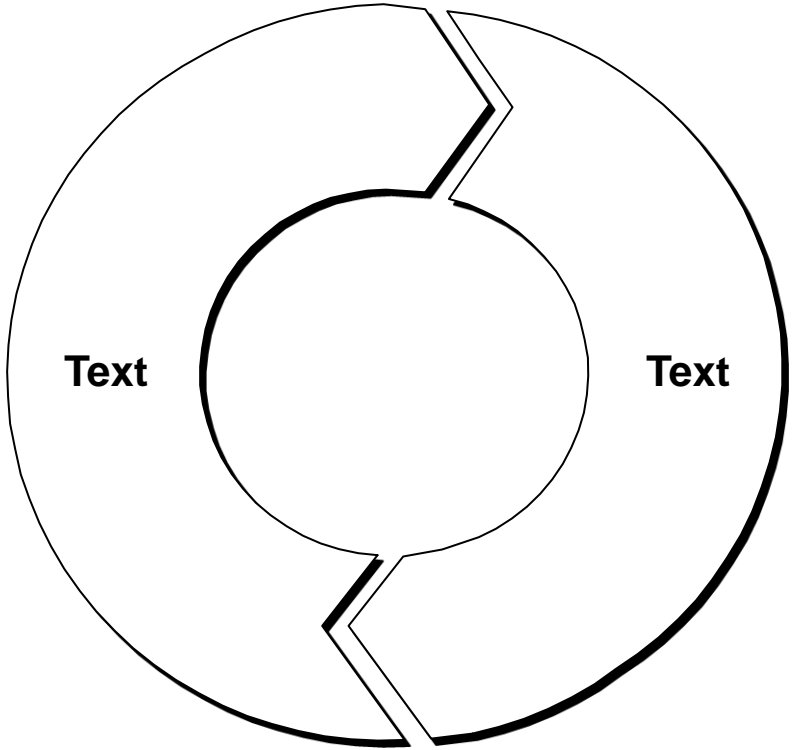

• Text

* Footnote

CYCLE 3

Unit of measure

• Text

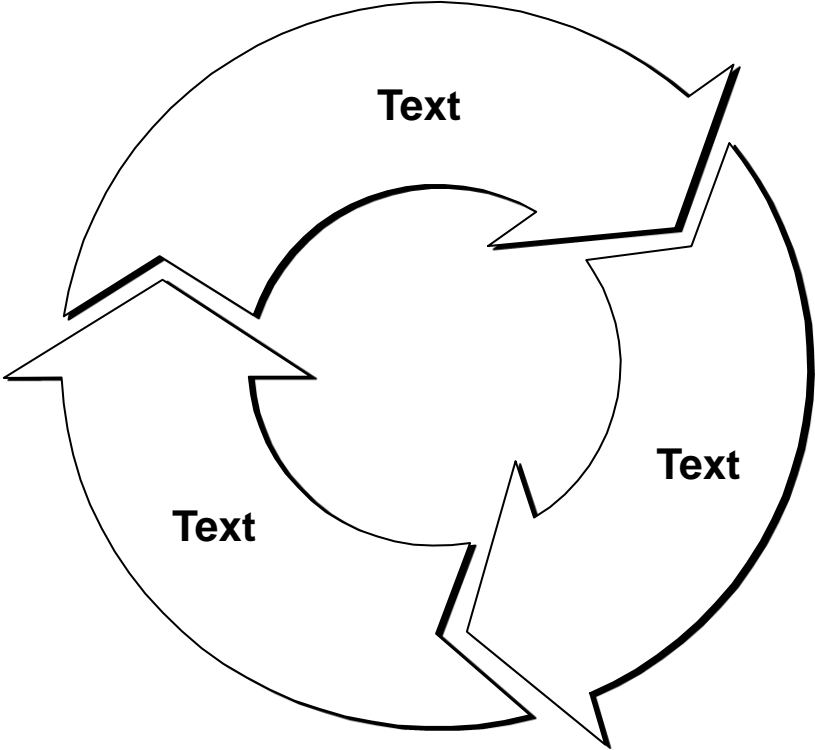

• Text

• Text

* Footnote

CYCLE 3

Unit of measure

• Text

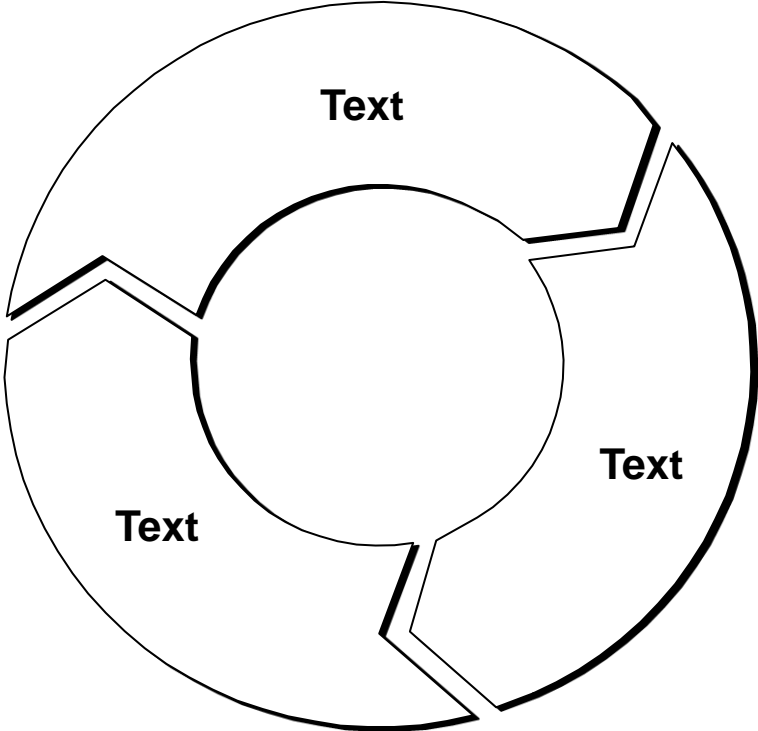

• Text

• Text

* Footnote

CYCLE 4

Unit of measure

• Text

• Text

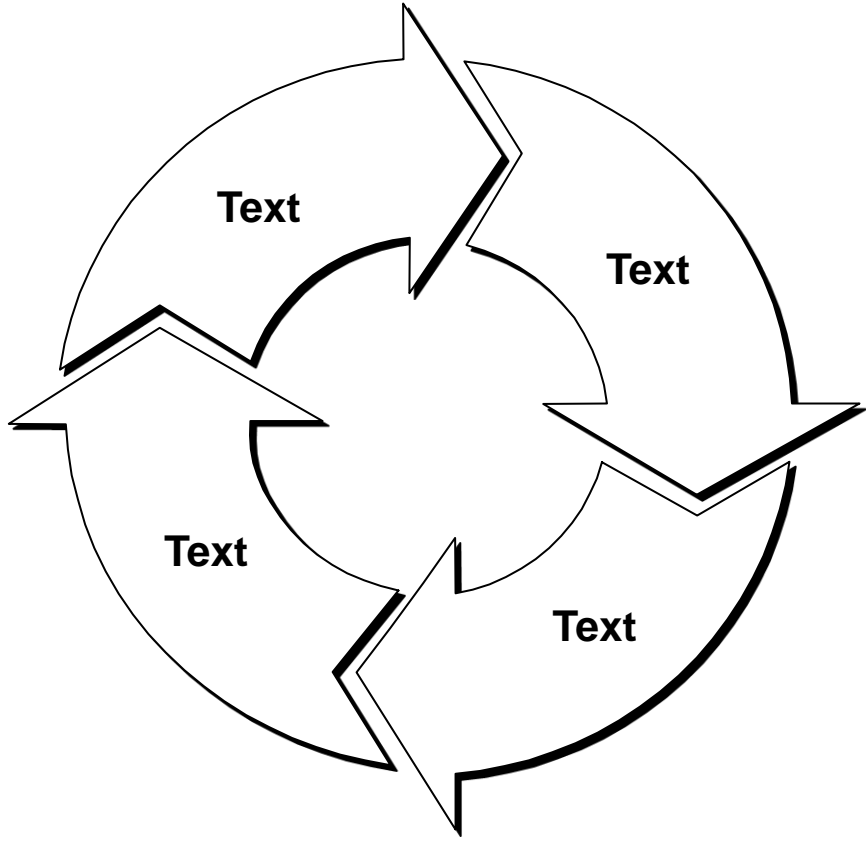

• Text

• Text

* Footnote

CYCLE 4

Unit of measure

• Text

• Text

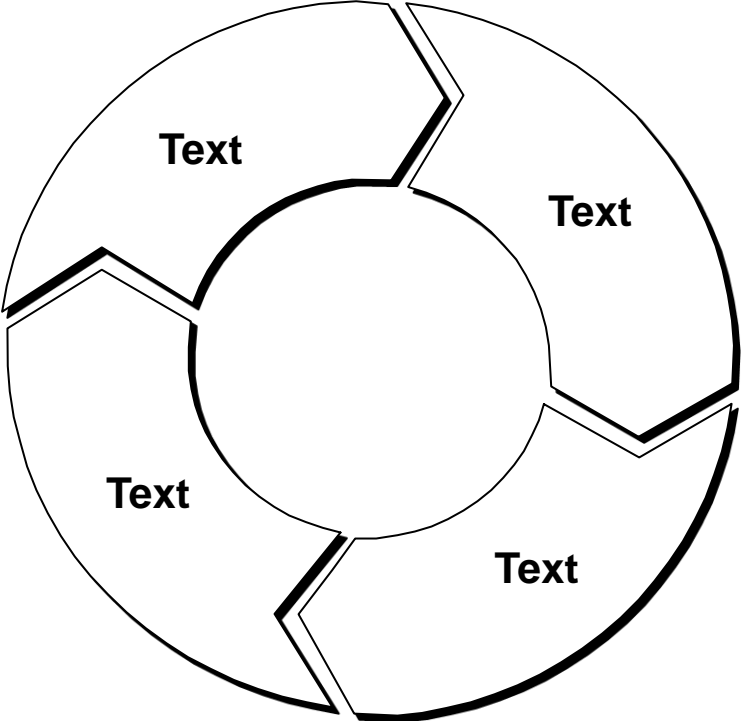

• Text

• Text

* Footnote

CYCLE 5

Unit of measure

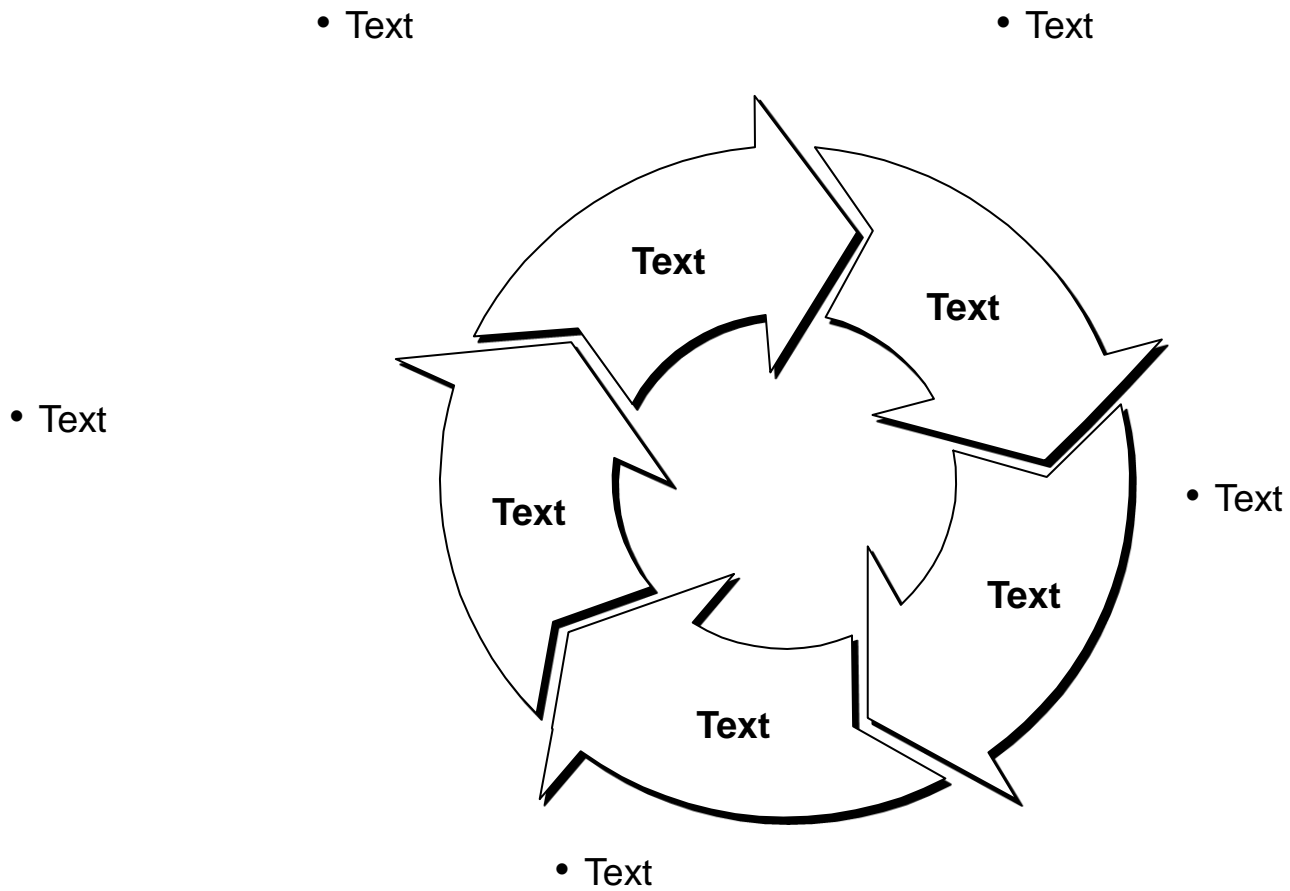

* Footnote

CYCLE 5

Unit of measure

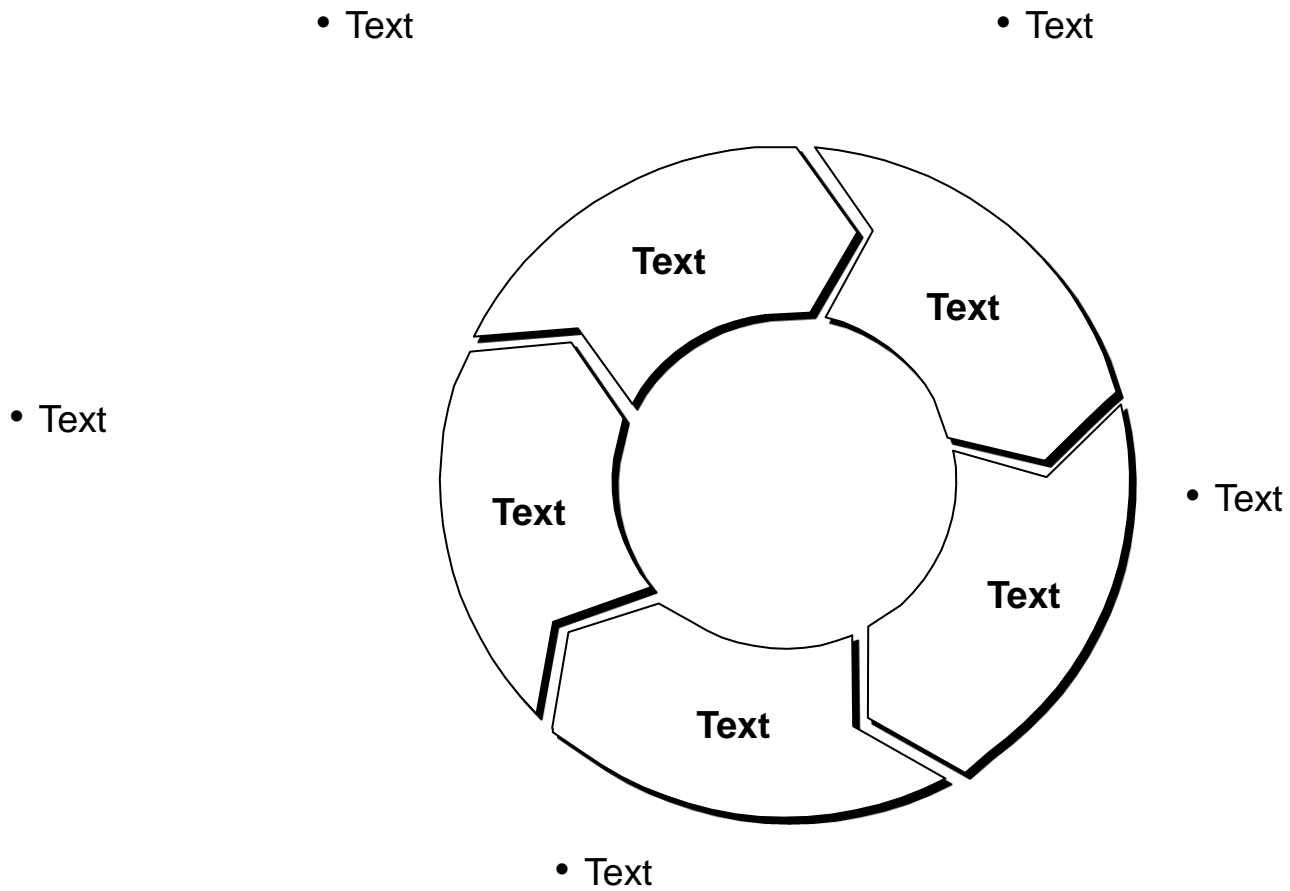

* Footnote

CYCLE 6

Unit of measure

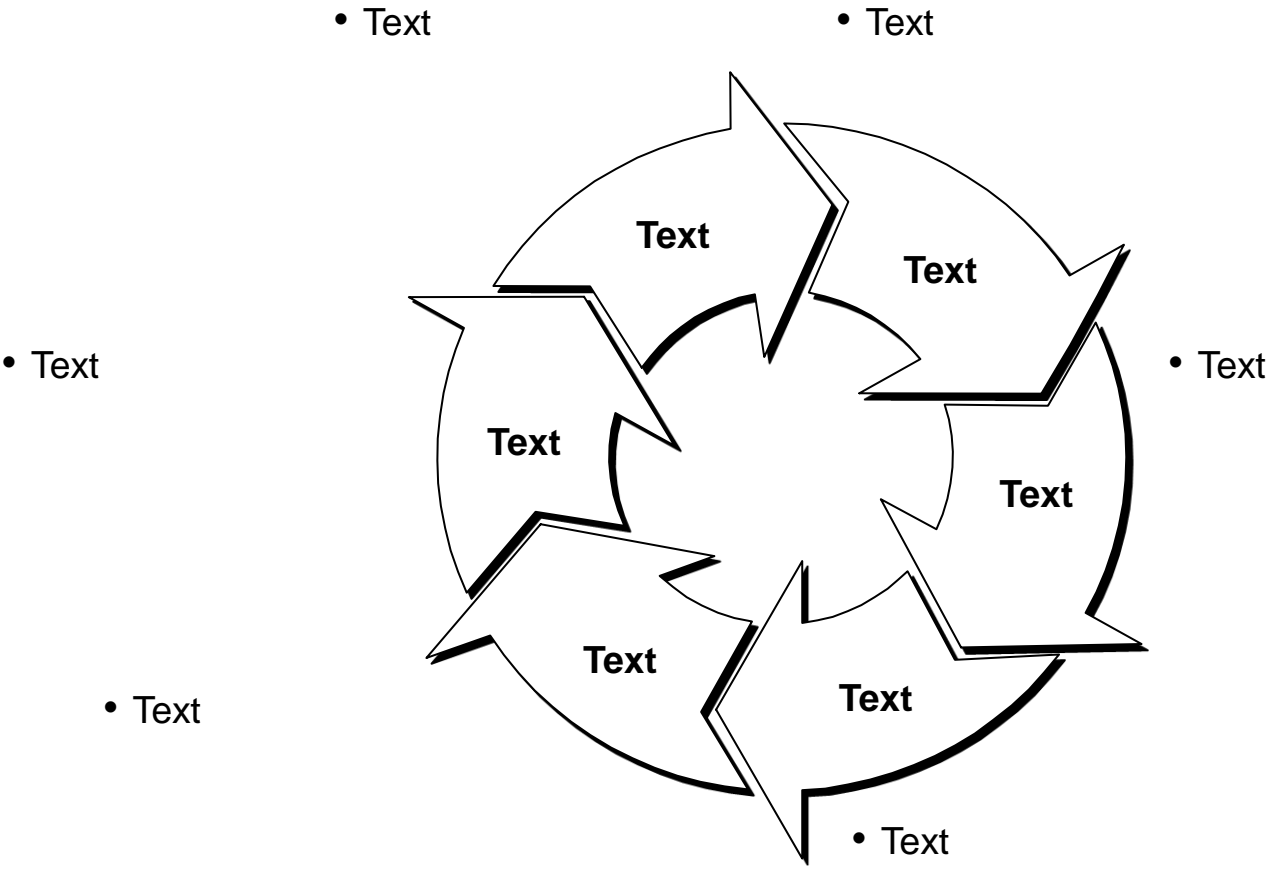

* Footnote

CYCLE 6

Unit of measure

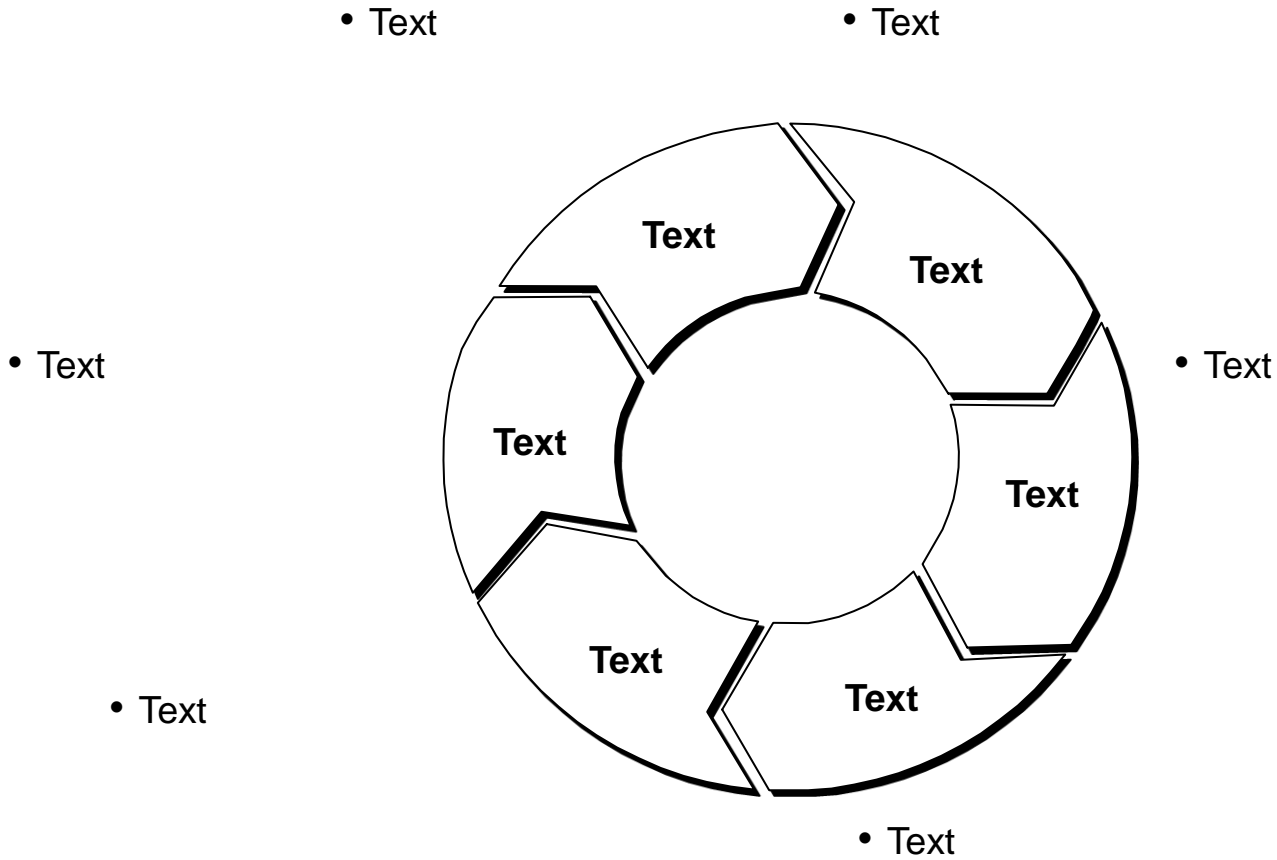

* Footnote

FORCES AT WORK

Unit of measure

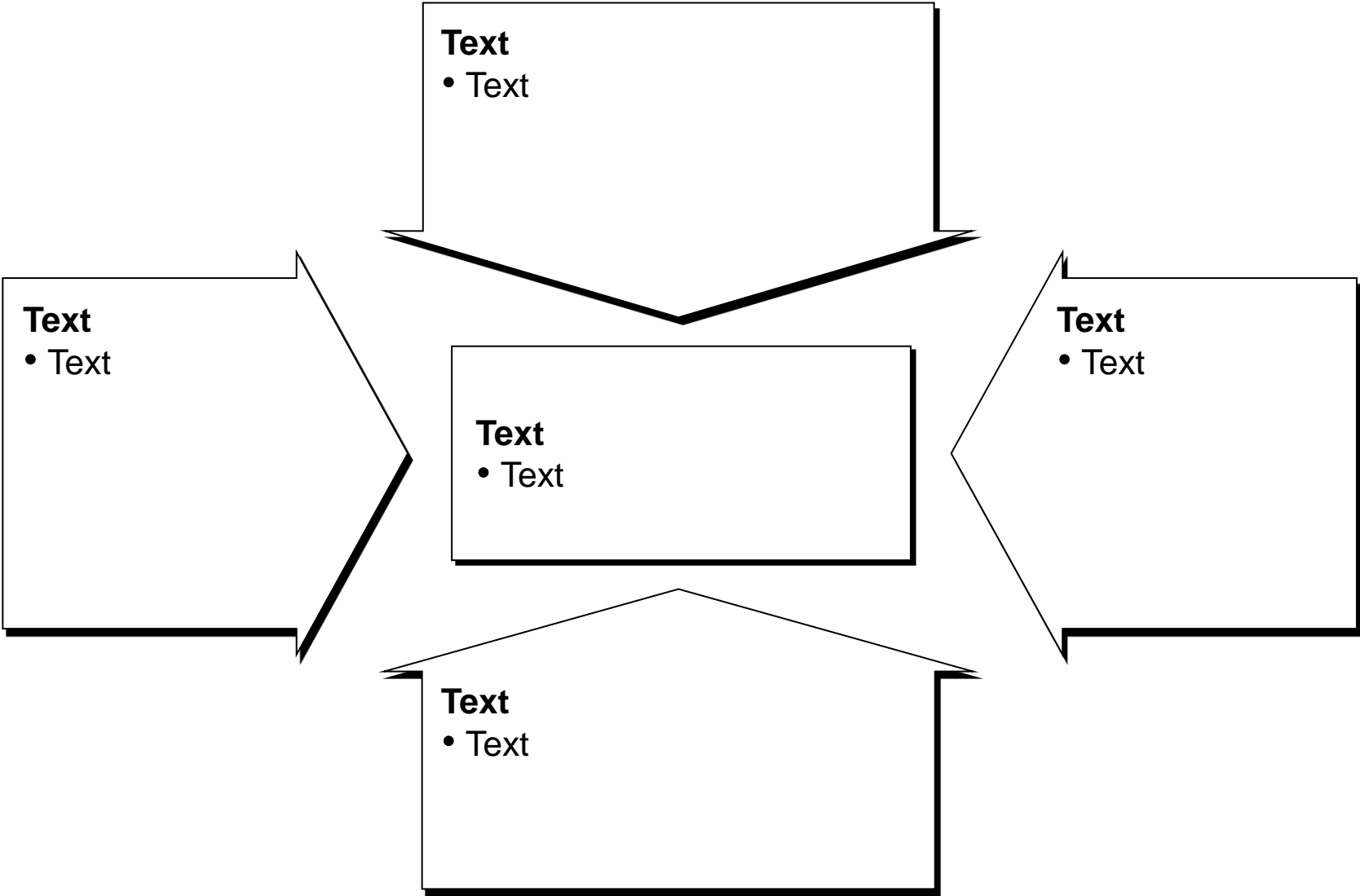

* Footnote

2 BY 2 MATRIX

Unit of measure

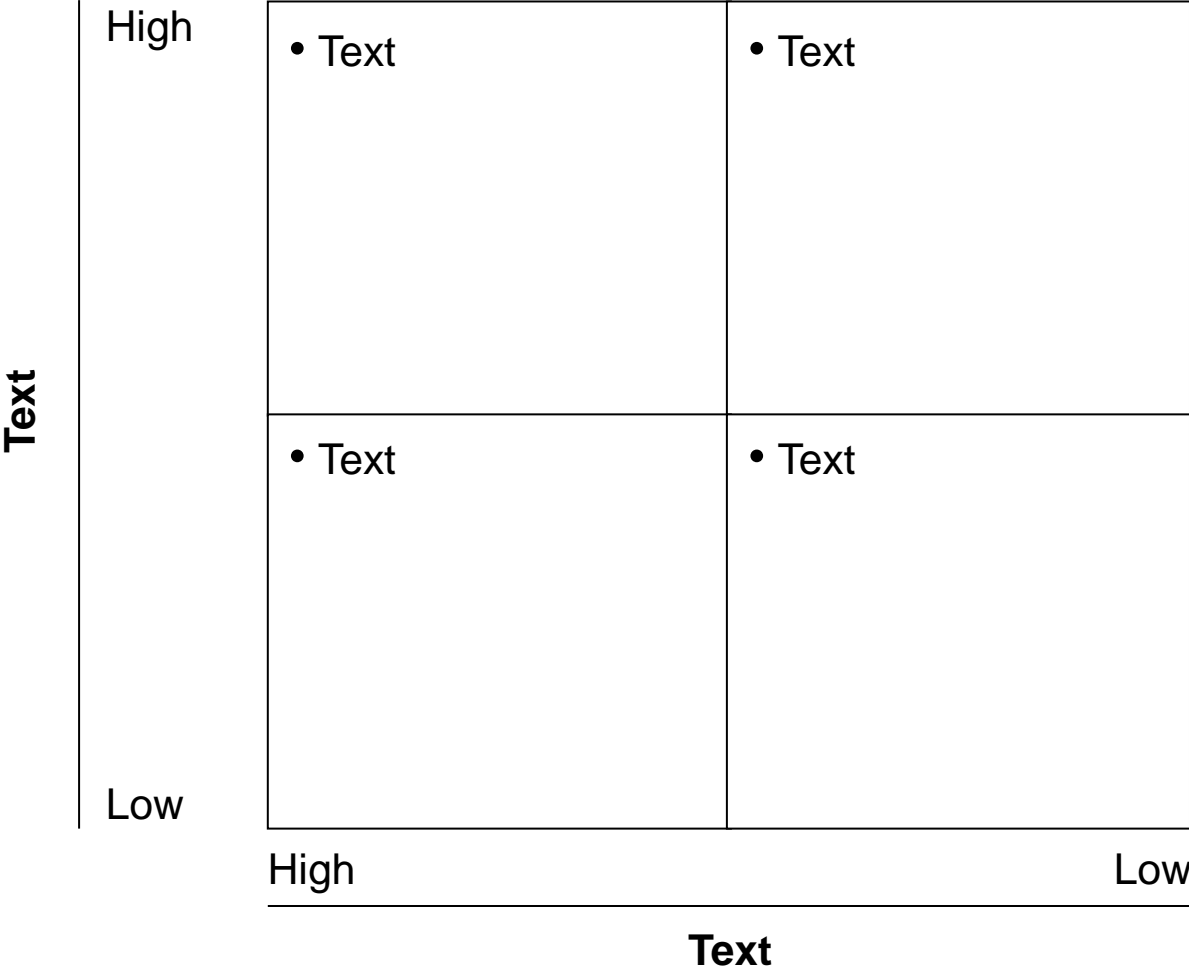

* Footnote

2 BY 3 MATRIX

Unit of measure

Text	High	• Text	• Text	• Text
	Low	• Text	• Text	• Text
		Low	Medium	High

Text

* Footnote

3 BY 3 MATRIX

Unit of measure

Text	High	• Text	• Text	• Text
	Medium	• Text	• Text	• Text
	Low	• Text	• Text	• Text
		Low	Medium	High

Text

* Footnote

4 BY 3 MATRIX

Unit of measure

Text	High	• Text	• Text	• Text	• Text
	Medium	• Text	• Text	• Text	• Text
	Low	• Text	• Text	• Text	• Text
		1	2	3	4

Text

* Footnote

4 BY 3 MATRIX

Unit of measure

Text	4	• Text	• Text	• Text	• Text
	3	• Text	• Text	• Text	• Text
	2	• Text	• Text	• Text	• Text
	1	• Text	• Text	• Text	• Text
		1	2	3	4
		Text			

* Footnote

STUDY OBJECTIVE

Unit of measure

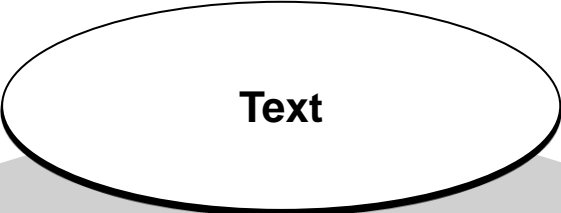

- Text

- Text

- Text

- Text

* Footnote

LEVEL 03

Unit of measure

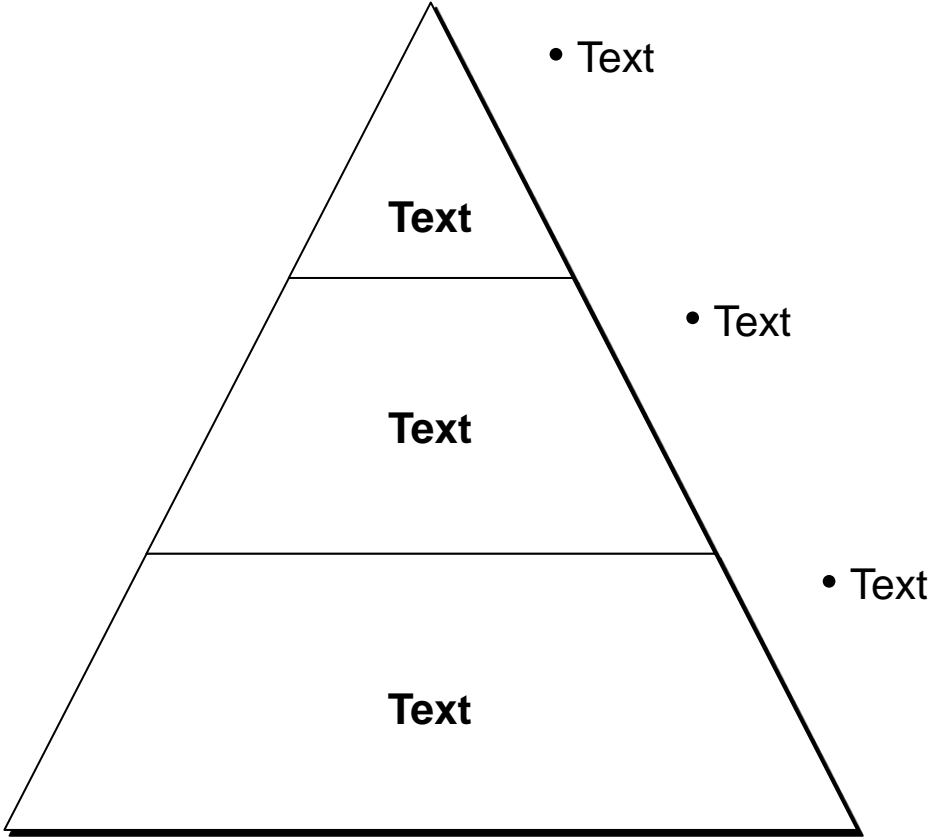

* Footnote

LEVEL 04

Unit of measure

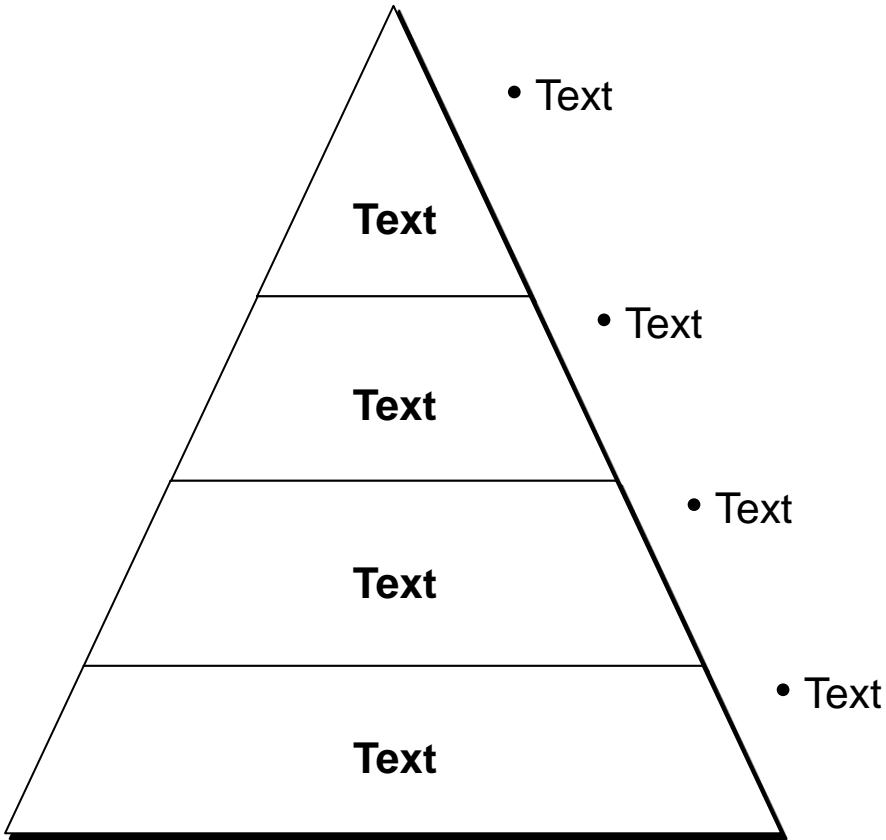

* Footnote

LEVEL 09

Unit of measure

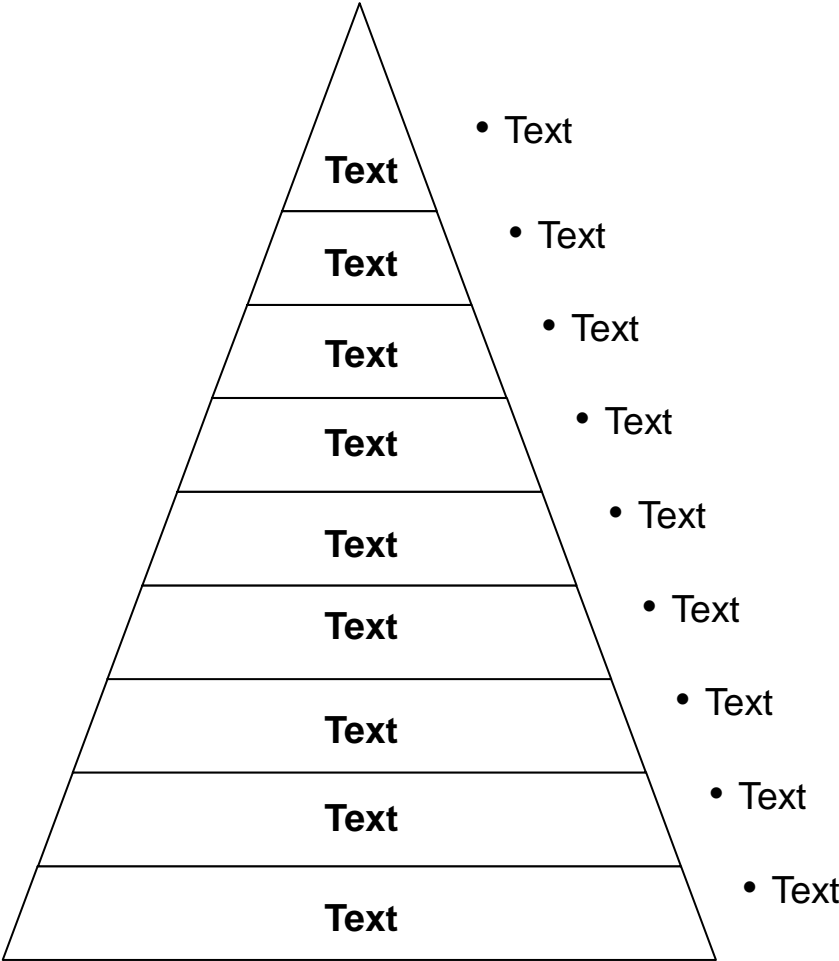

* Footnote

GANTT – 4 WEEK

Unit of measure

Text	Text	Text	Text	Text	
<ul style="list-style-type: none">• Text • Text • Text	<hr/>			▲	

* Footnote

Unit of measure

Text	Text	Text	Text	Text	Text	Text
<ul style="list-style-type: none">• Text • Text • Text						

* Footnote

Unit of measure

Text	Text				Text			
	Text	Text	Text	Text	Text	Text	Text	Text
• Text								
• Text								
• Text								

* Footnote

Unit of measure

Text	Text				Text				Text			
	Text	Text	Text	Text	Text	Text	Text	Text	Text	Text	Text	Text
• Text												
• Text												
• Text												

* Footnote

Unit of measure

Text	Text				Text				Text				Text			
	1	2	3	4	1	2	3	4	1	2	3	4	1	2	3	4
• Text																
• Text																
• Text																

* Footnote
Source: Source

Unit of measure

Text	Text				Text				Text				Text							
	1	2	3	4	1	2	3	4	1	2	3	4	1	2	3	4	1	2	3	4
• Text																				
• Text																				
• Text																				

* Footnote
Source: Source

Unit of measure

Text	Text				Text				Text				Text				Text							
	1	2	3	4	1	2	3	4	1	2	3	4	1	2	3	4	1	2	3	4	1	2	3	4
• Text																								
• Text																								
• Text																								

* Footnote
Source: Source

Unit of measure

Text	Text				Text				Text				Text				Text				Text							
	1	2	3	4	1	2	3	4	1	2	3	4	1	2	3	4	1	2	3	4	1	2	3	4	1	2	3	4
• Text																												
• Text																												
• Text																												

* Footnote
Source: Source

Unit of measure

	Text				Text				Text				Text				Text				Text				Text							
Text	1	2	3	4	1	2	3	4	1	2	3	4	1	2	3	4	1	2	3	4	1	2	3	4	1	2	3	4	1	2	3	4
• Text																																
• Text																																
• Text																																

* Footnote
Source: Source

Unit of measure

	Text	Text	Text	Text	Text	Text	Text	Text	Text
Text	1 2 3 4	1 2 3 4	1 2 3 4	1 2 3 4	1 2 3 4	1 2 3 4	1 2 3 4	1 2 3 4	1 2 3 4
• Text									
• Text									
• Text									

* Footnote
Source: Source

Unit of measure

	Text	Text	Text	Text	Text	Text	Text	Text	Text	Text
Text	1 2 3 4	1 2 3 4	1 2 3 4	1 2 3 4	1 2 3 4	1 2 3 4	1 2 3 4	1 2 3 4	1 2 3 4	1 2 3 4
• Text										
• Text										
• Text										

* Footnote
Source: Source

Unit of measure

	Text	Text	Text	Text	Text	Text	Text	Text	Text	Text	Text	Text
Text	1 2 3 4	1 2 3 4	1 2 3 4	1 2 3 4	1 2 3 4	1 2 3 4	1 2 3 4	1 2 3 4	1 2 3 4	1 2 3 4	1 2 3 4	1 2 3 4
• Text												
• Text												
• Text												

* Footnote
Source: Source

Unit of measure

Text	Text												
	1	2	3	4	5	6	7	8	9	10	11	12	
• Text													
• Text													
• Text													

* Footnote
Source: Source

Unit of measure

Text	Text												Text											
	1	2	3	4	5	6	7	8	9	10	11	12	1	2	3	4	5	6	7	8	9	10	11	12
• Text																								
• Text																								
• Text																								

* Footnote
Source: Source

Unit of measure

Text	Responsibility	Text				
		Mon	Tue	Wed	Thu	Fri
<ul style="list-style-type: none"> • Text • Text • Text 						

* Footnote

Unit of measure

Text	Responsibility	Text					Text				
		M	T	W	T	F	M	T	W	T	F
• Text											
• Text											
• Text											

* Footnote

Unit of measure

Text

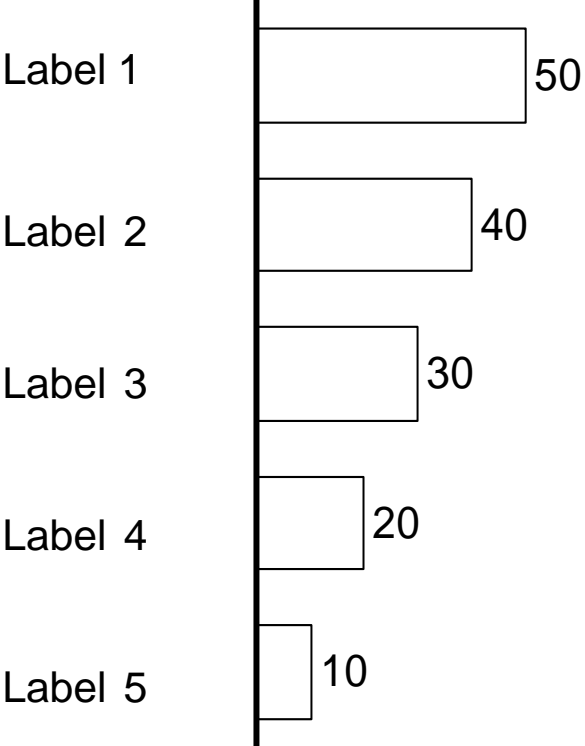

Text

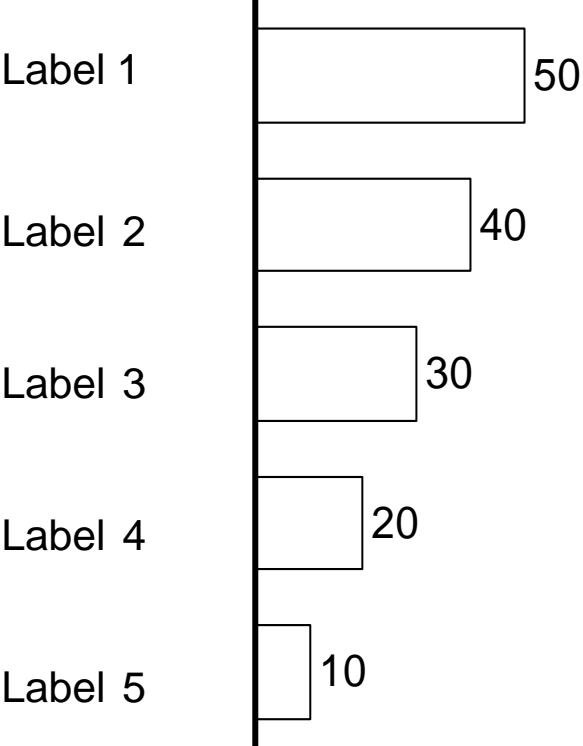

* Footnote

Unit of measure

Text

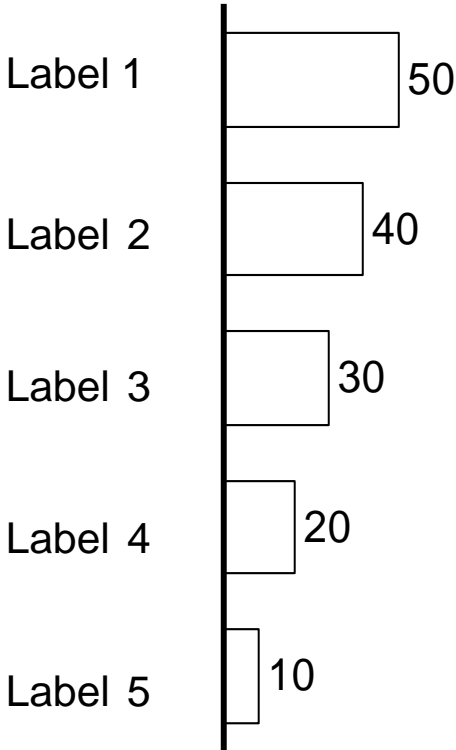

Text

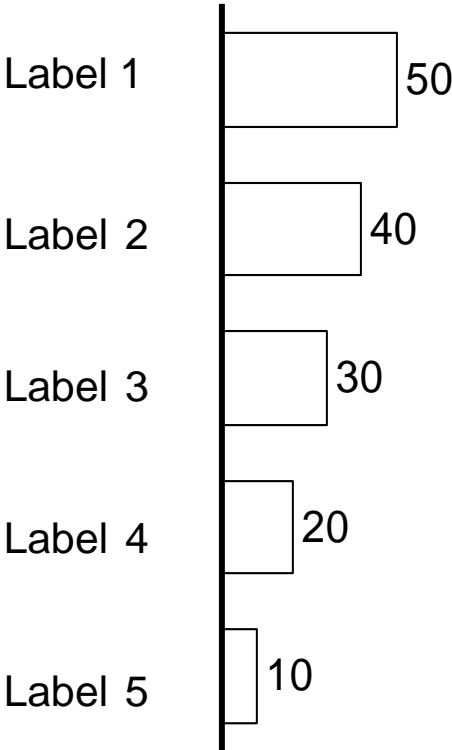

Text

* Footnote

Unit of measure

Text

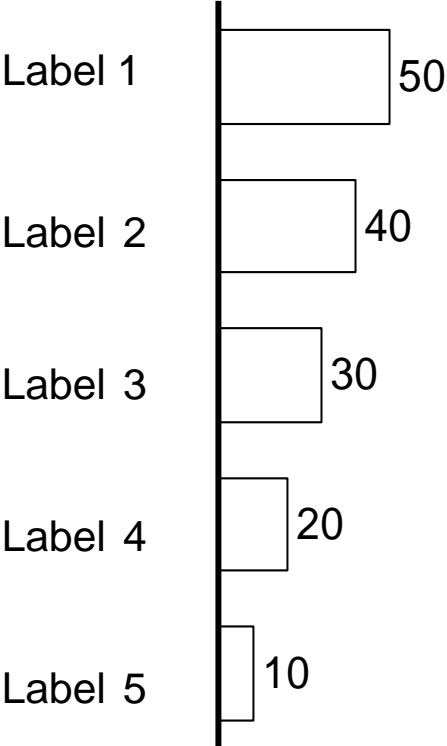

Text

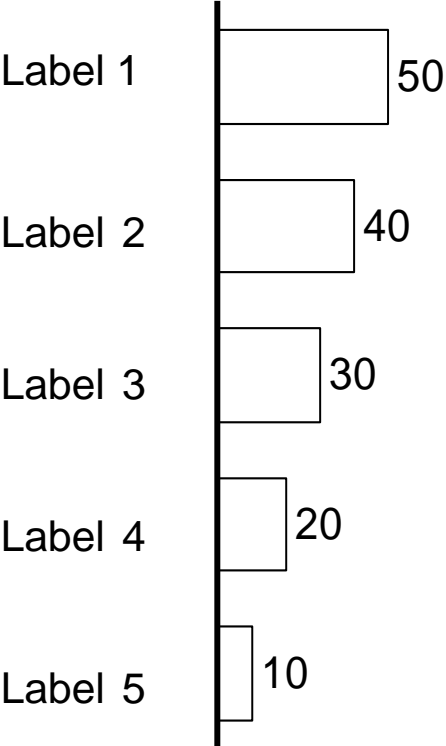

Text

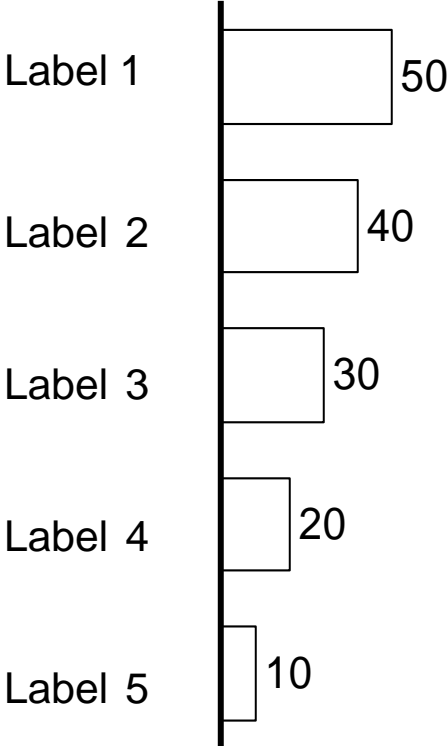

* Footnote

Unit of measure

Text

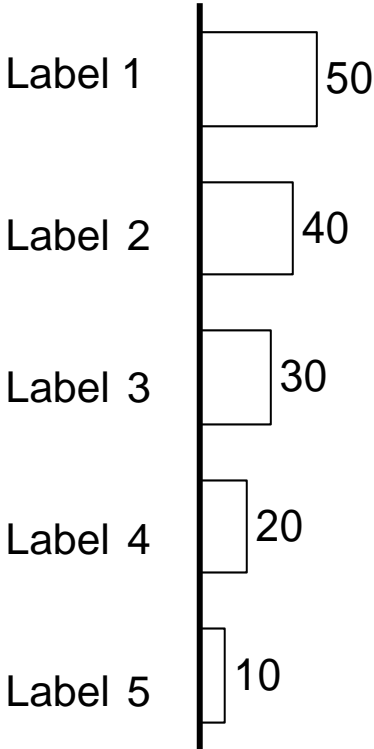

Text

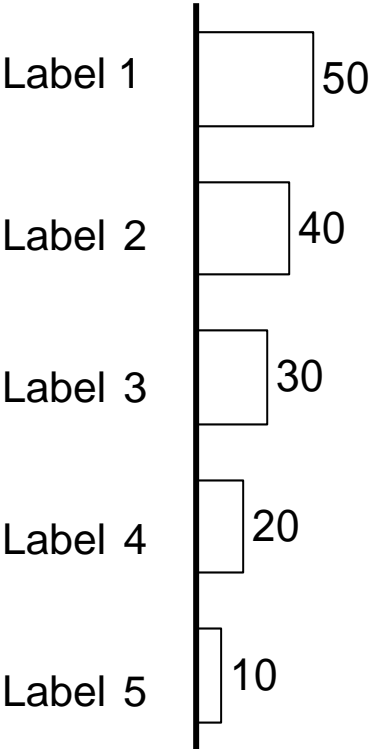

Text

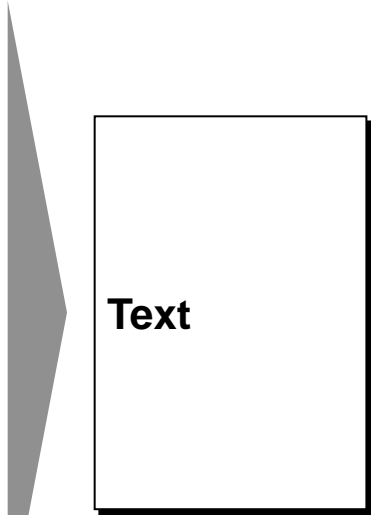
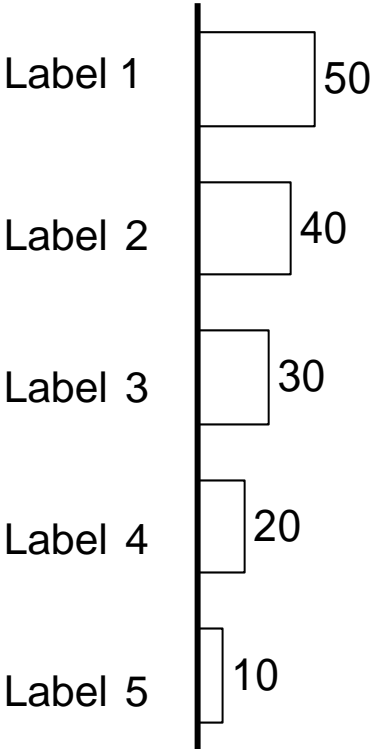

* Footnote

Unit of measure

Text

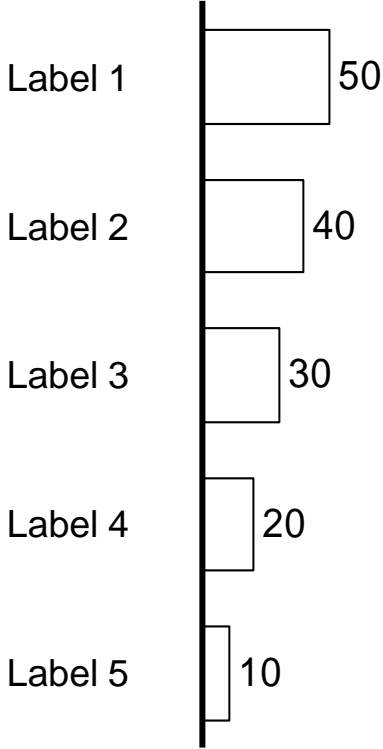

Text

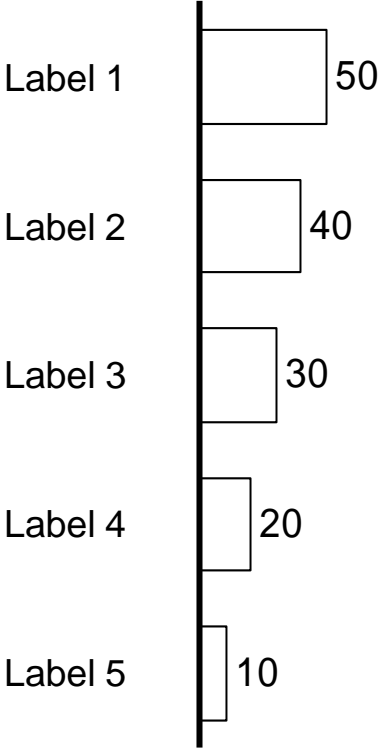

Text

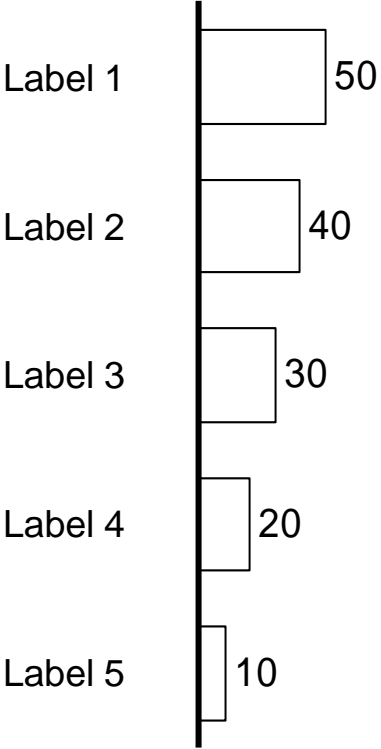

Text

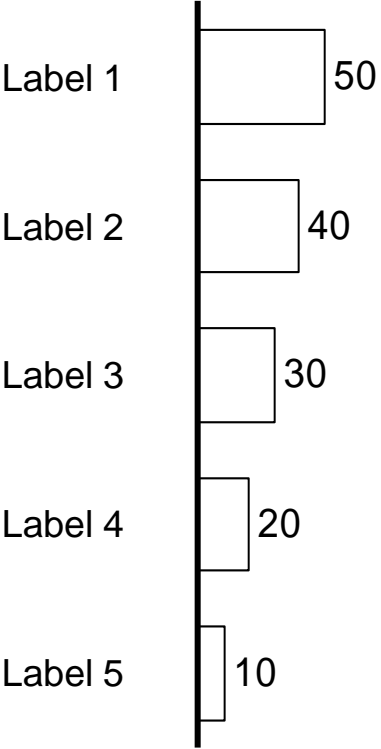

* Footnote

Unit of measure

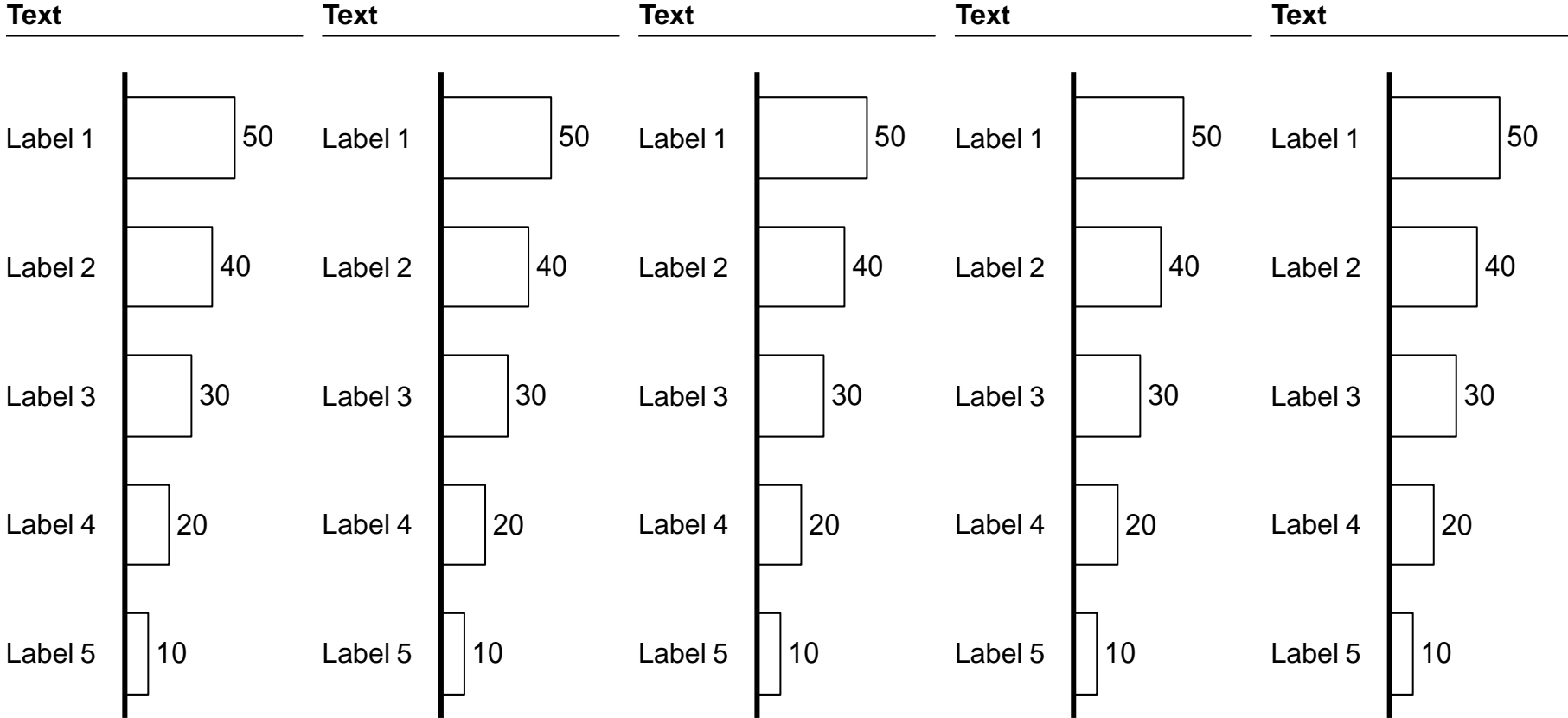

* Footnote
Source: Source

Unit of measure

Text

Text

Label 1

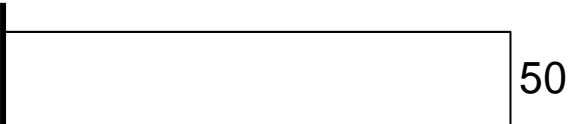

50

Label 2



40

Label 3

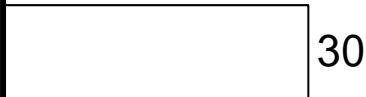

30

Label 4

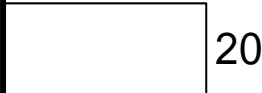

20

Label 5



10

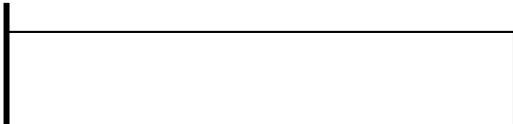

40

30

20

10

* Footnote

Unit of measure

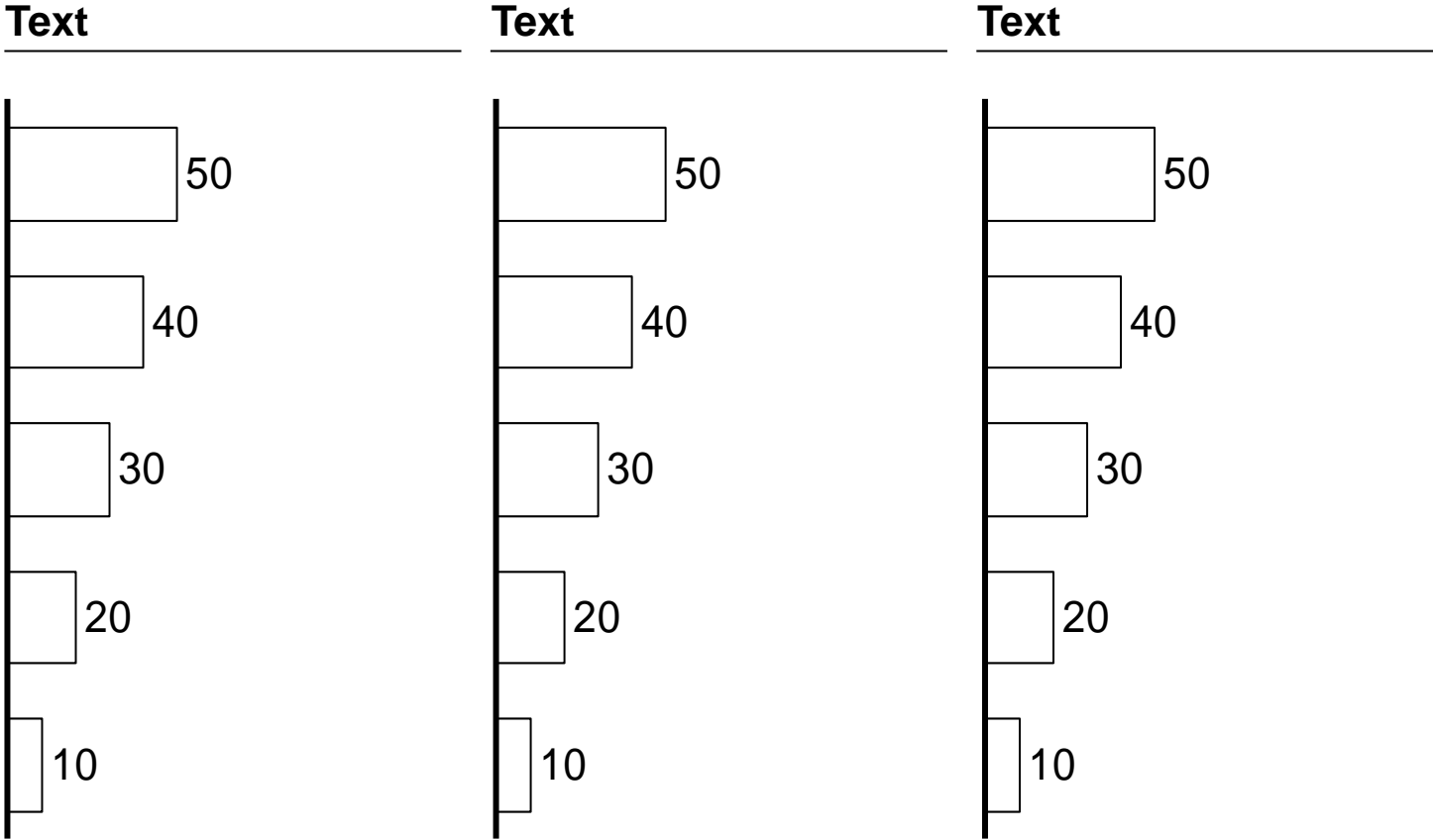

* Footnote

Unit of measure

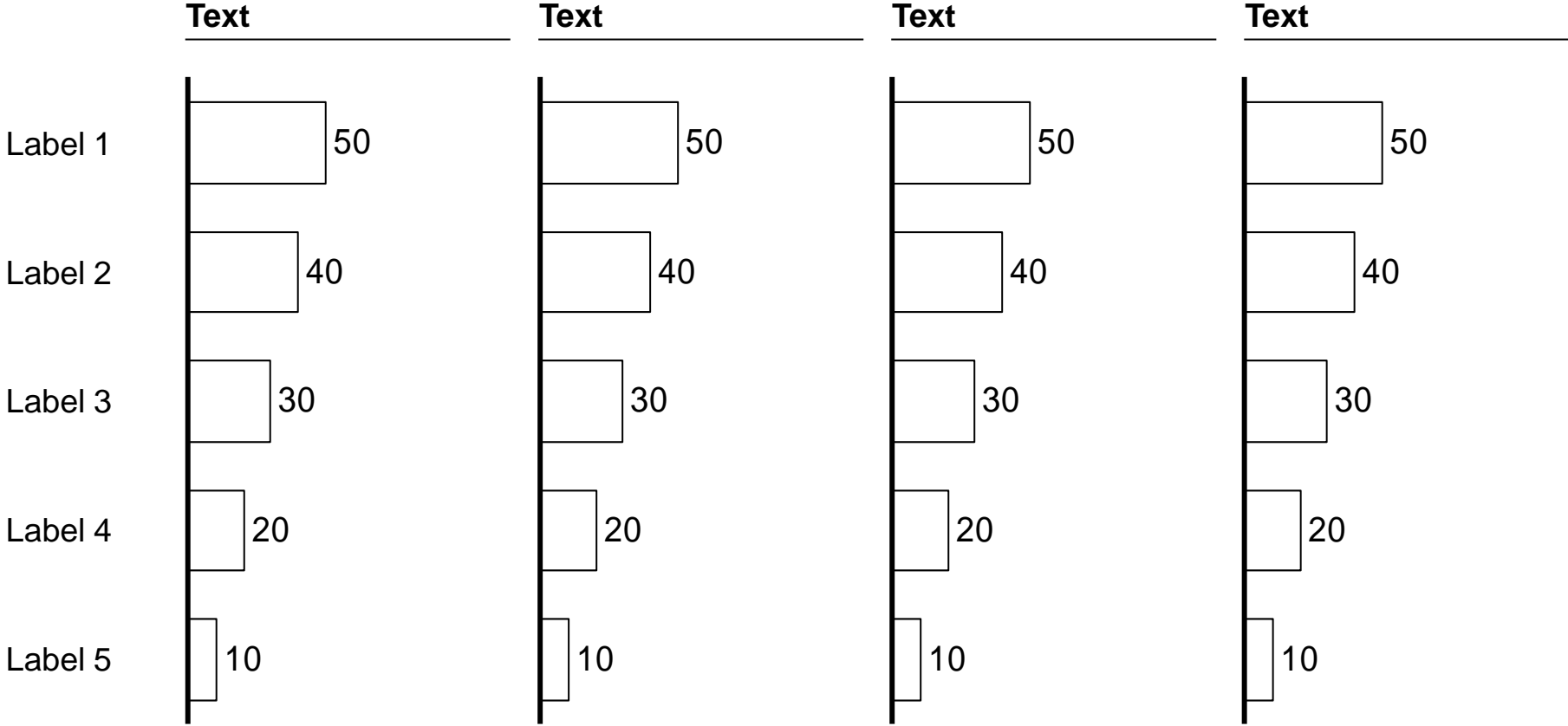

* Footnote

Unit of measure

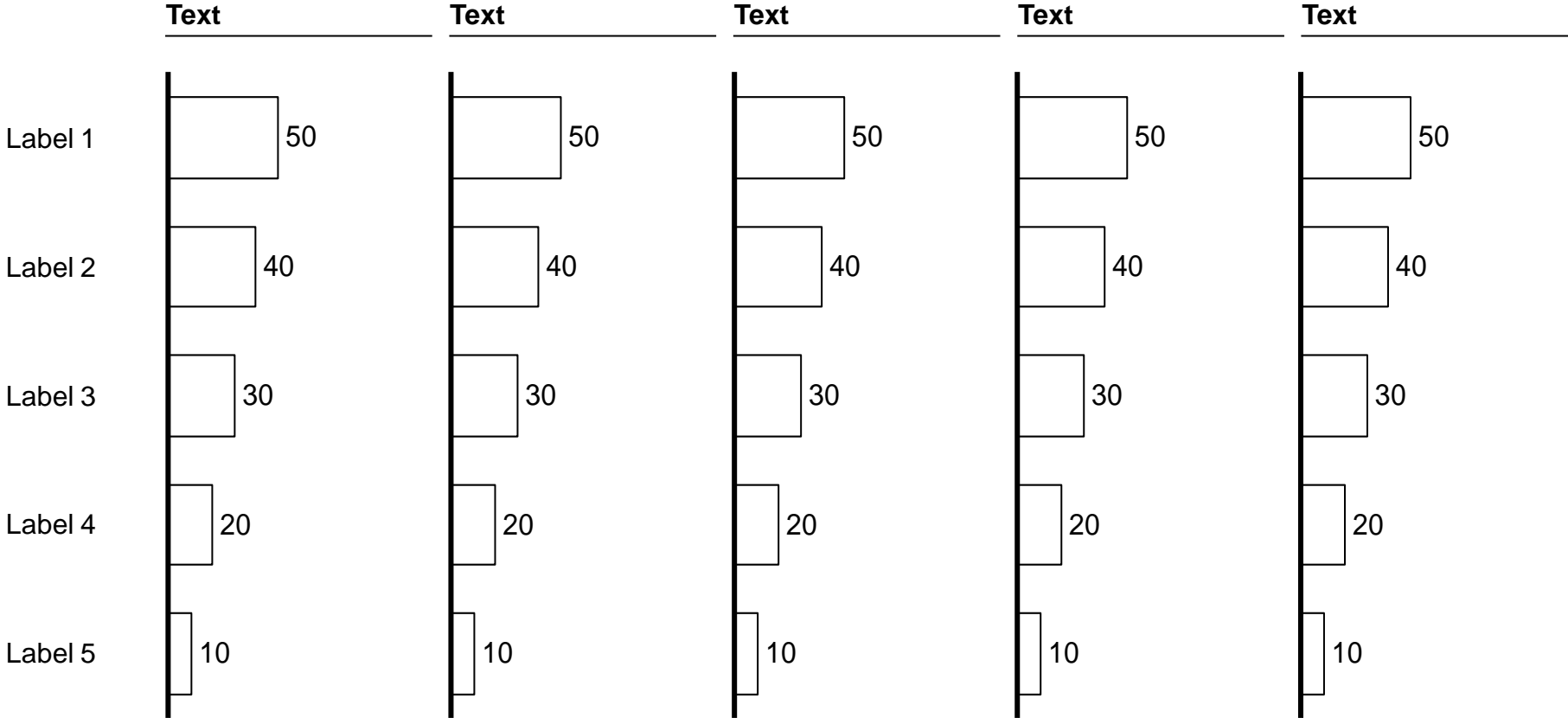

* Footnote
Source: Source

EXHIBIT TITLE

Unit of measure

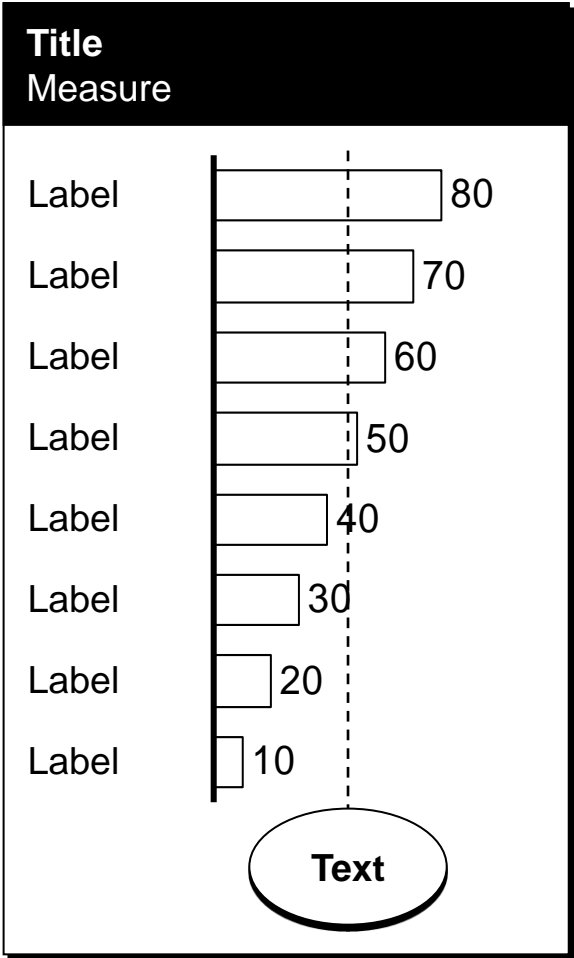
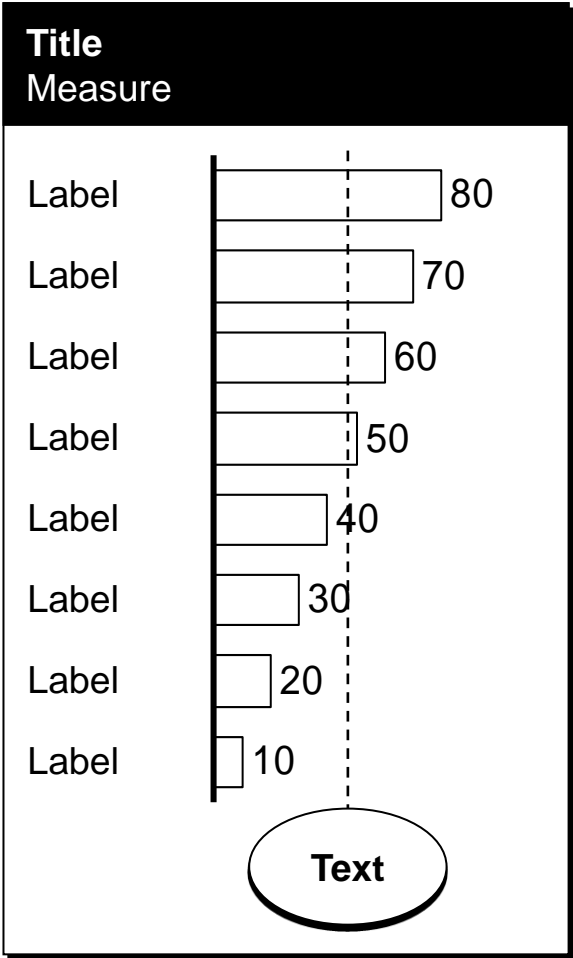
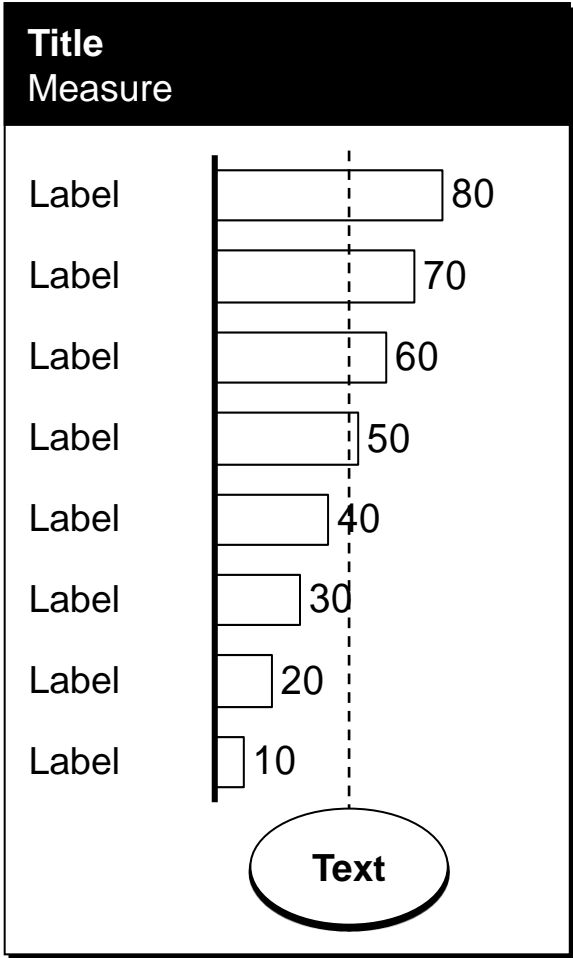

* Footnote

EXHIBIT TITLE

Unit of measure

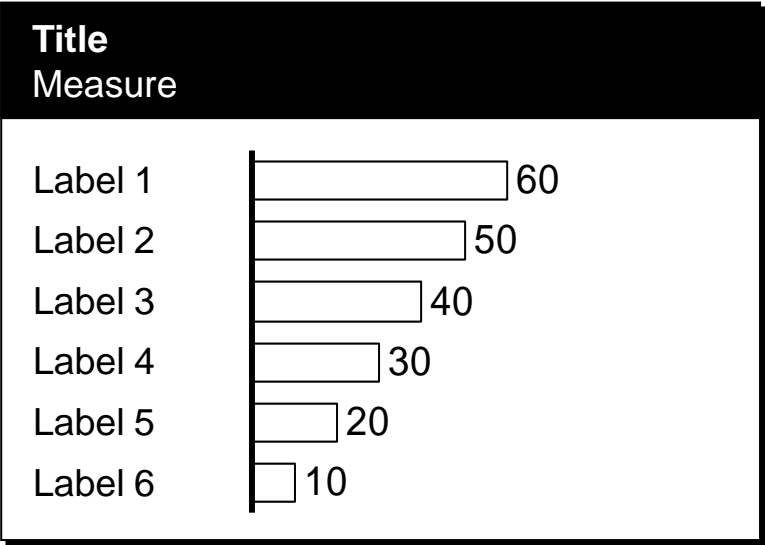
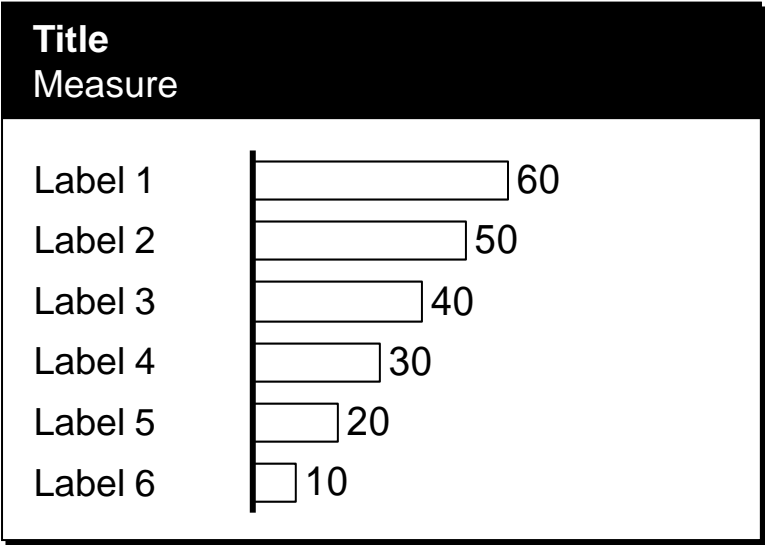
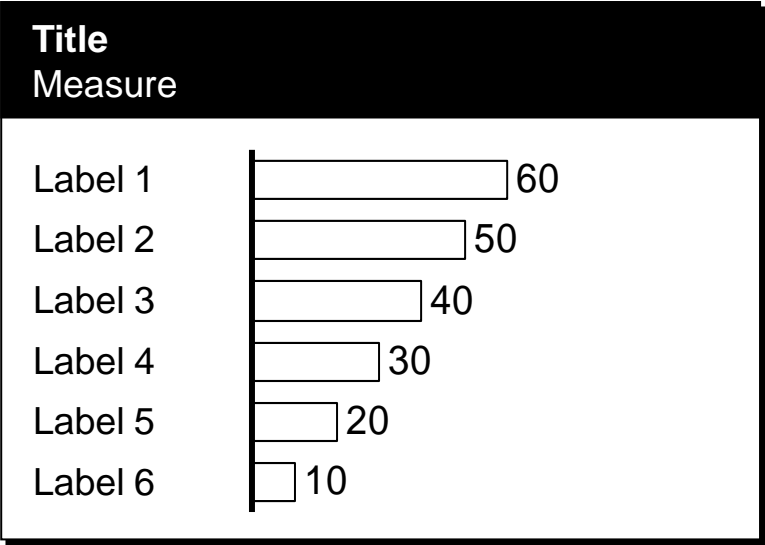
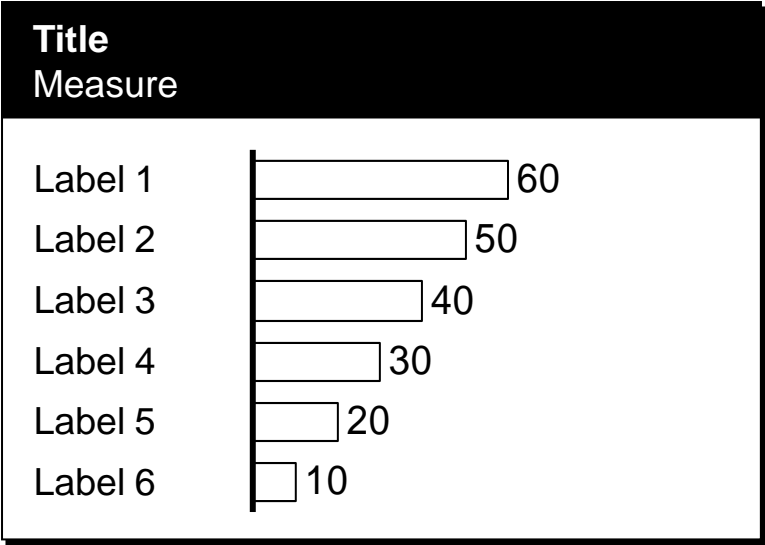

* Footnote

EXHIBIT TITLE

Unit of measure

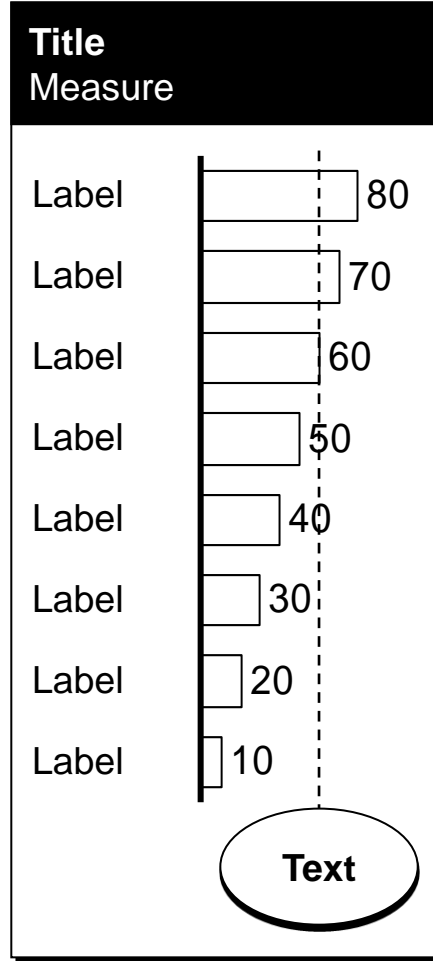
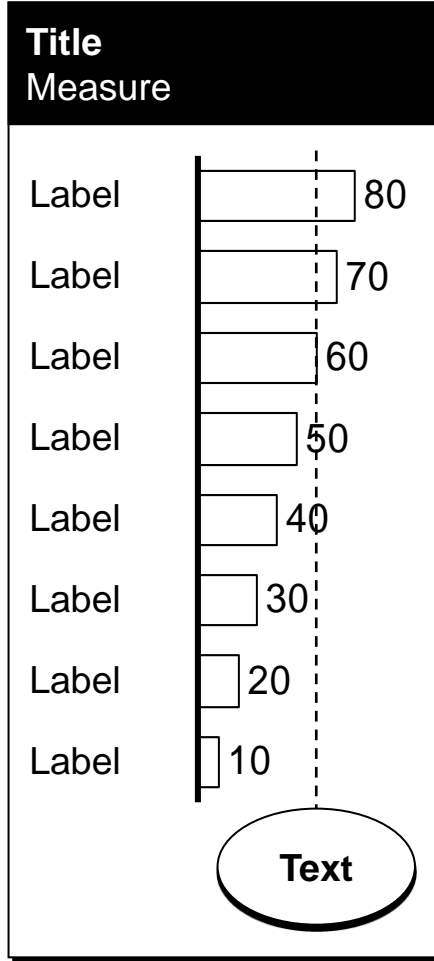
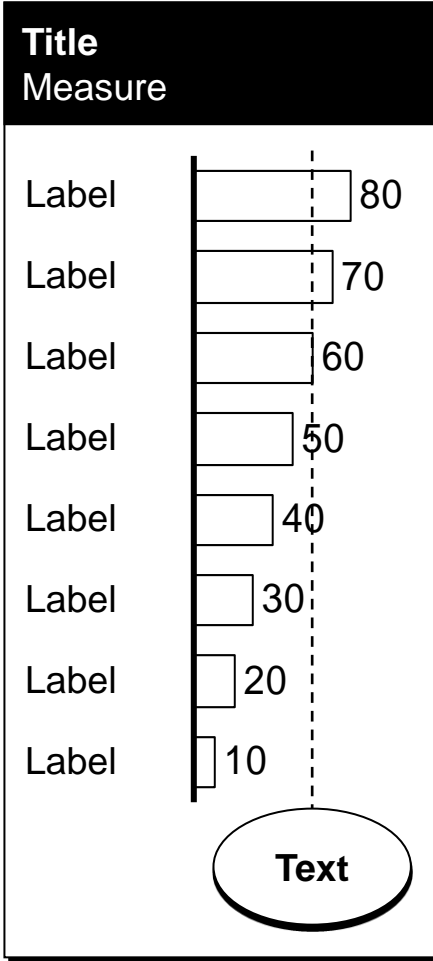
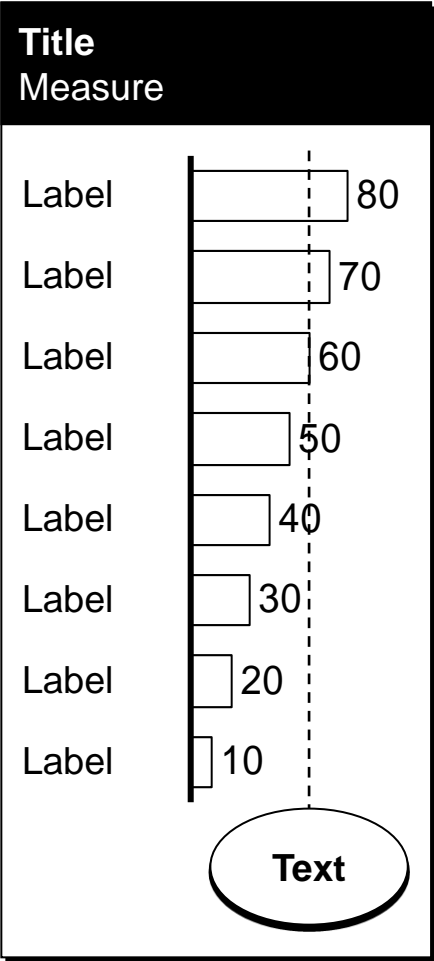

* Footnote

EXHIBIT TITLE

Unit of measure

Text

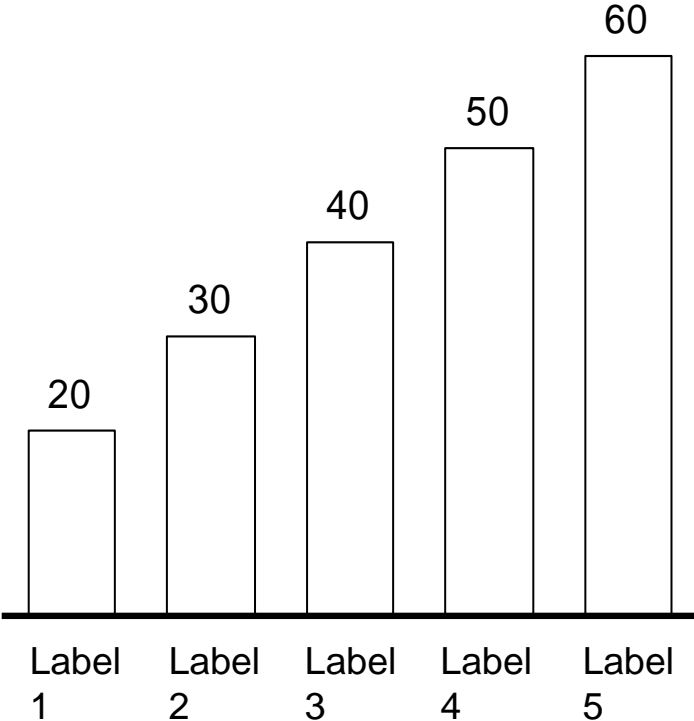

Text

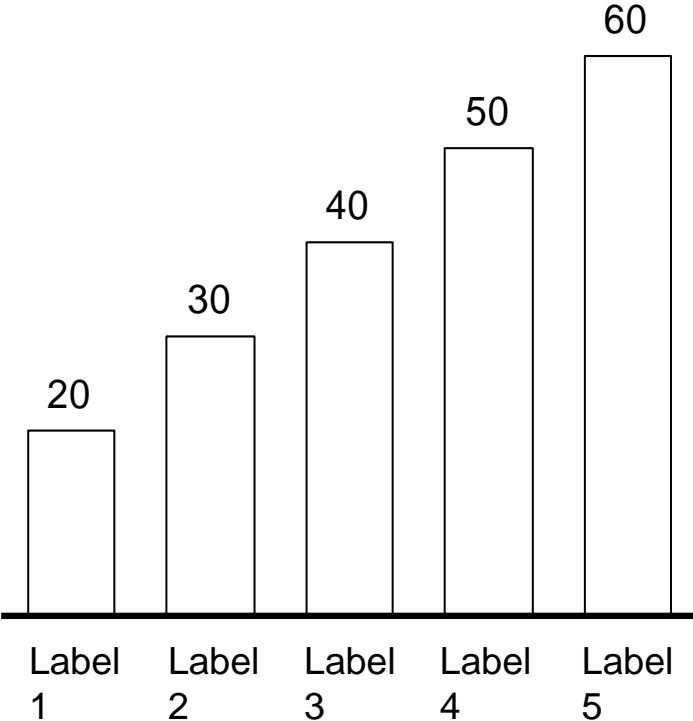

* Footnote

EXHIBIT TITLE

Unit of measure

Text

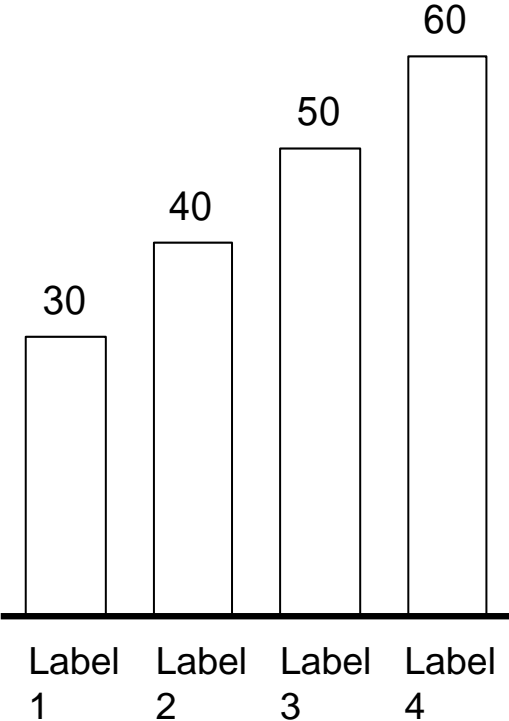

Text

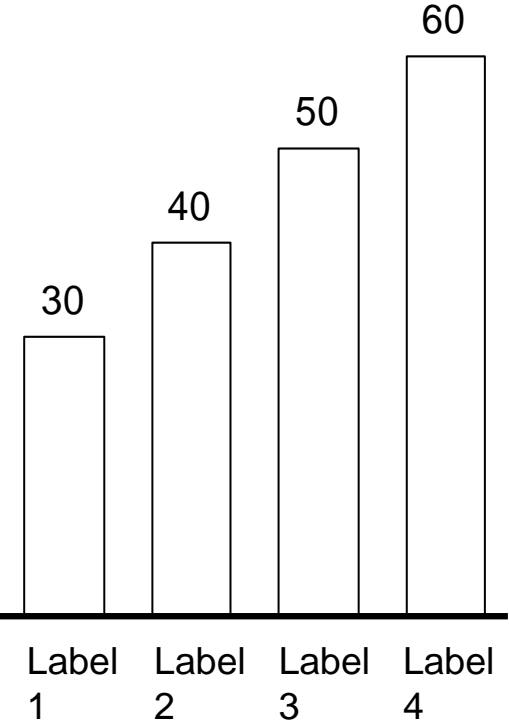

Text

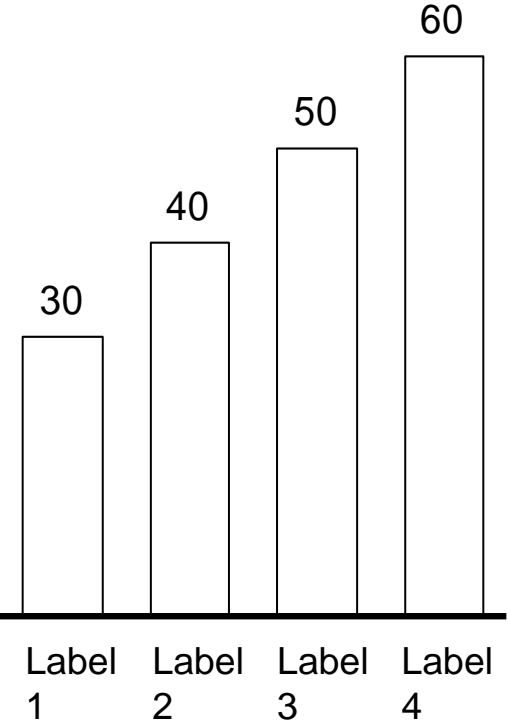

* Footnote

EXHIBIT TITLE

Unit of measure

Text

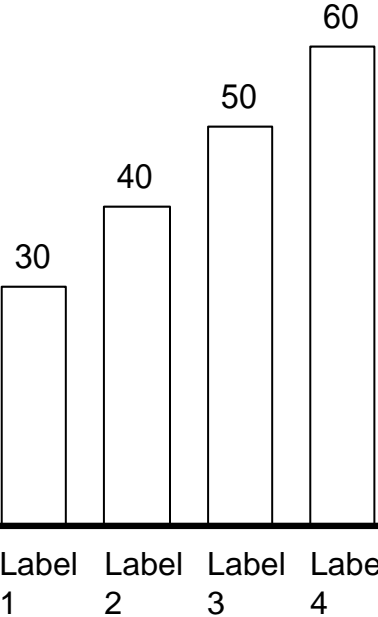

Text

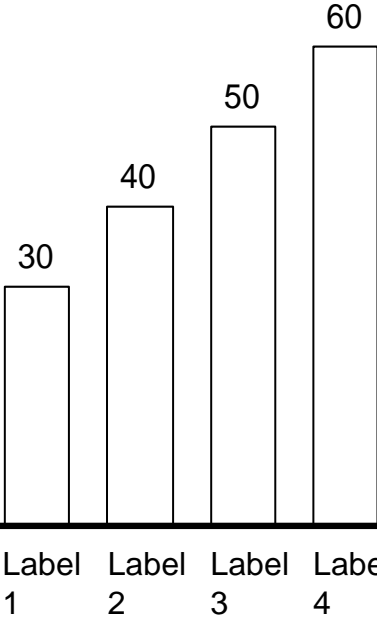

Text

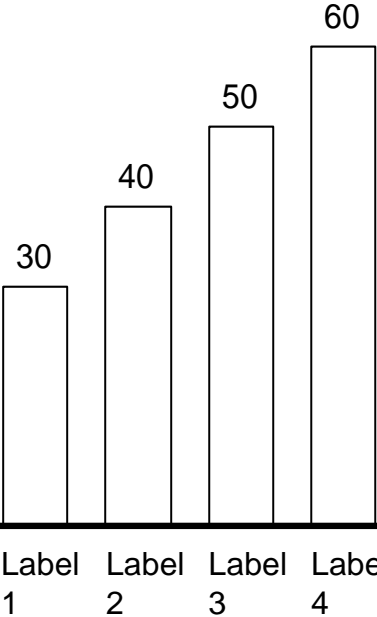

Text

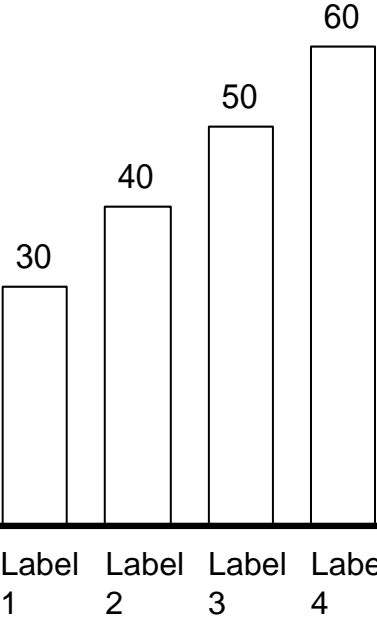

* Footnote

EXHIBIT TITLE

Unit of measure

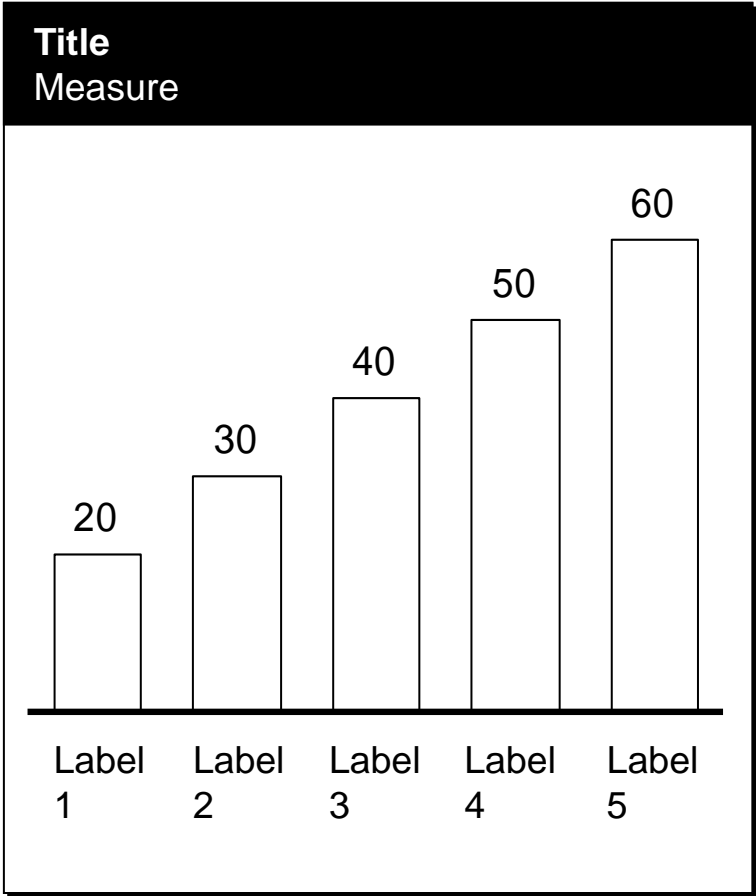
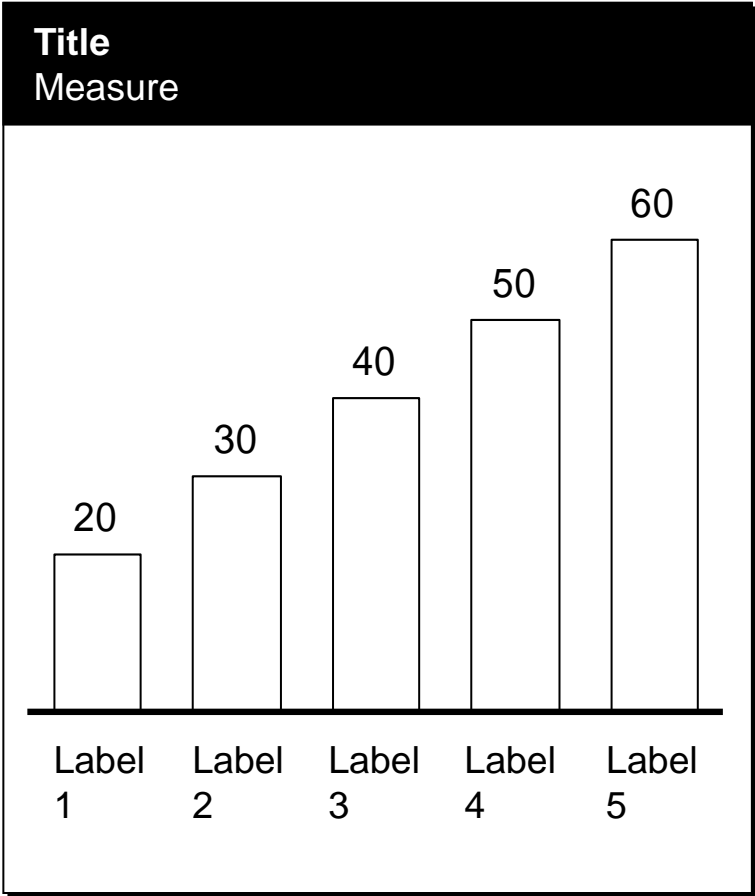

* Footnote

EXHIBIT TITLE

Unit of measure

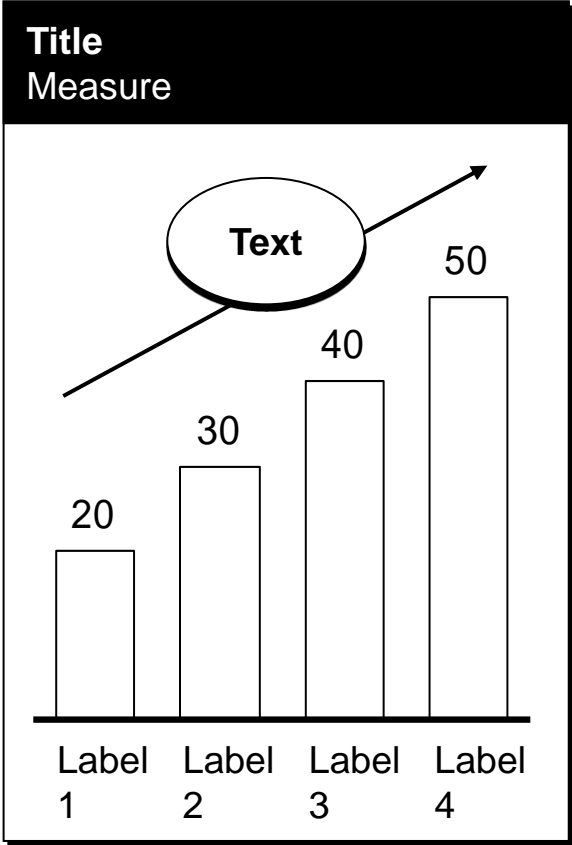
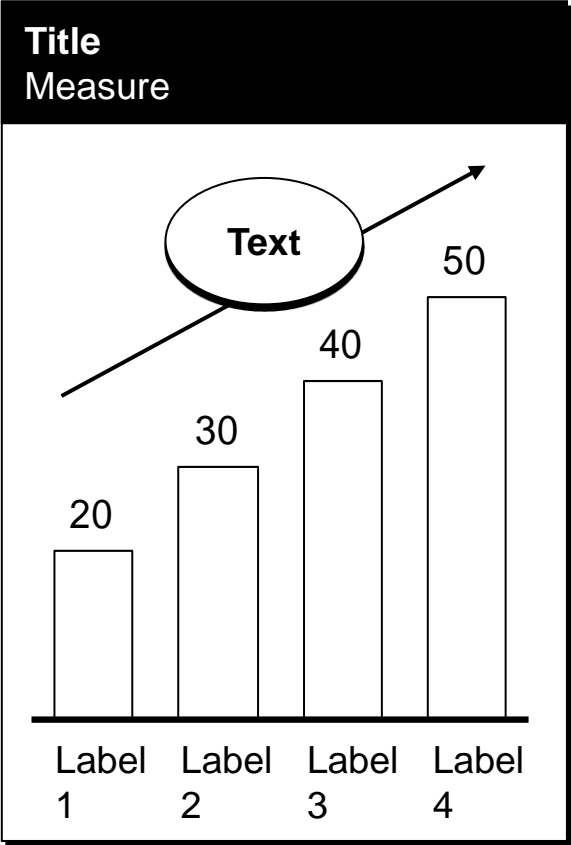
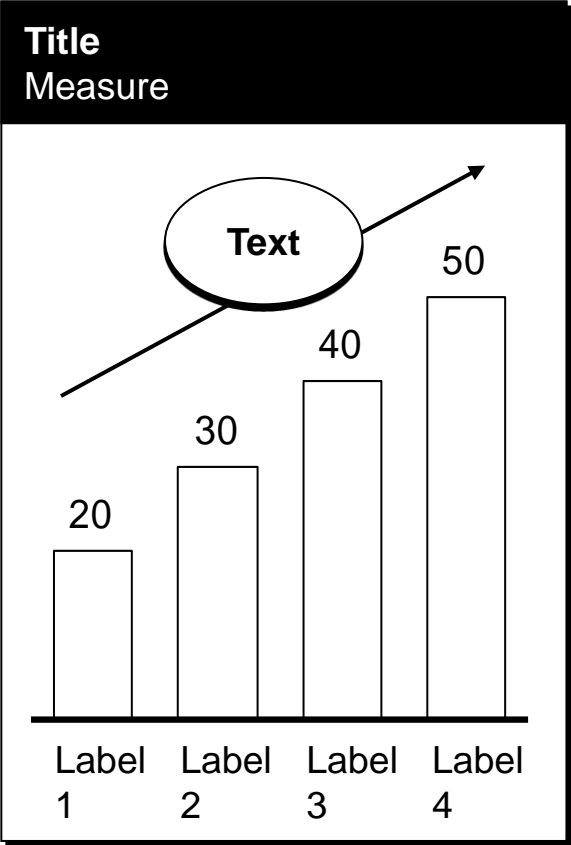

* Footnote

EXHIBIT TITLE

Unit of measure

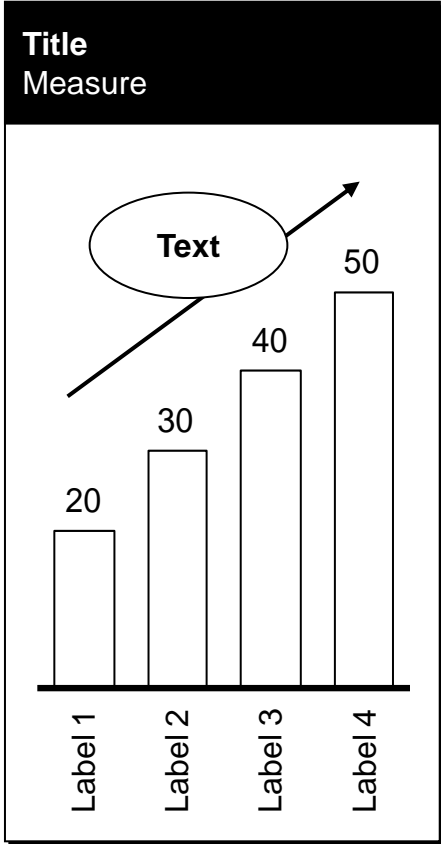
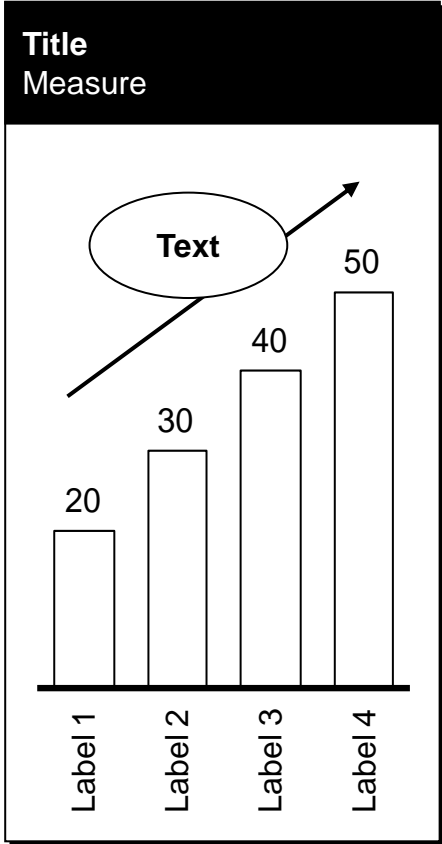
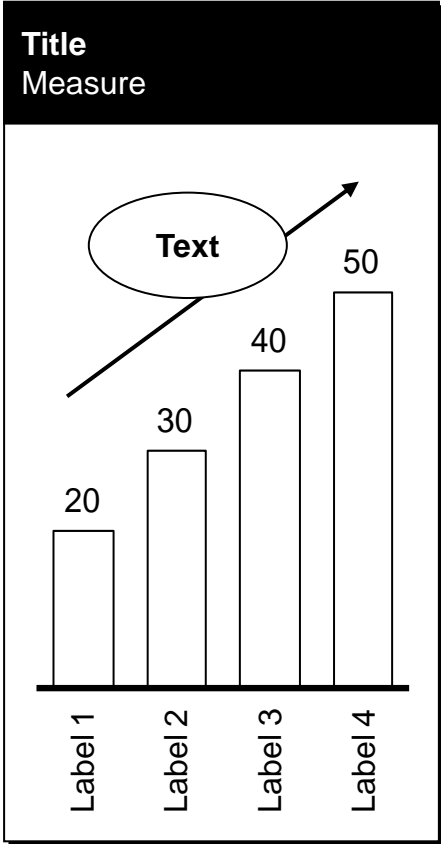
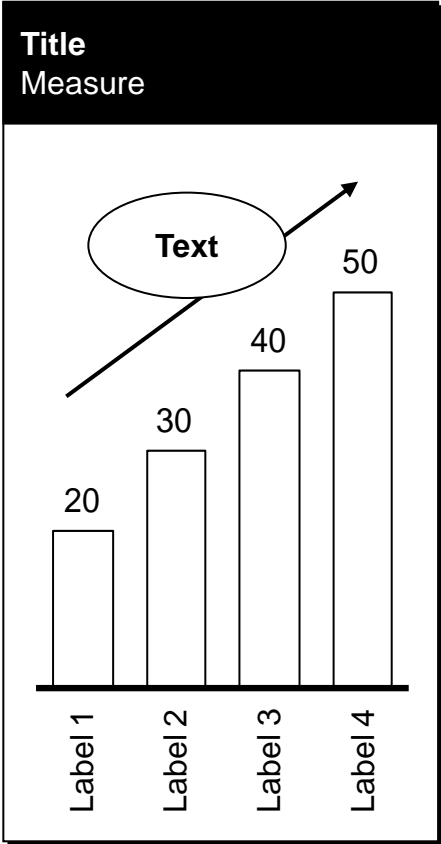

* Footnote
Source: Source

EXHIBIT TITLE

Unit of measure

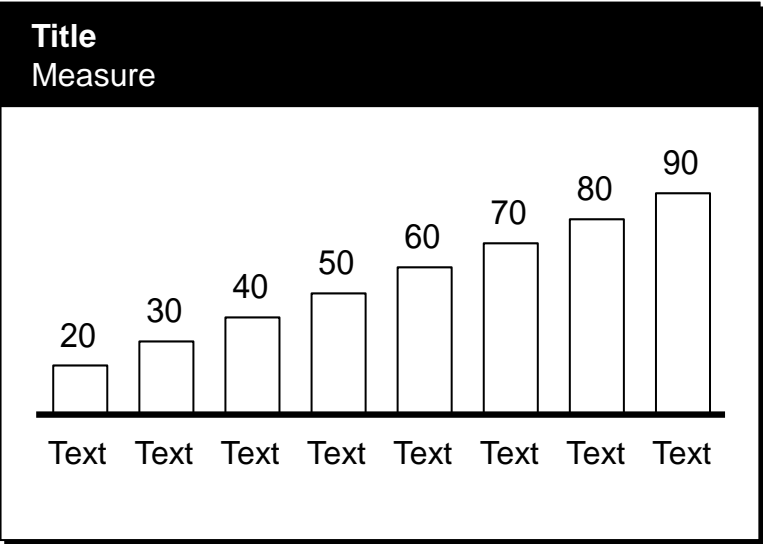
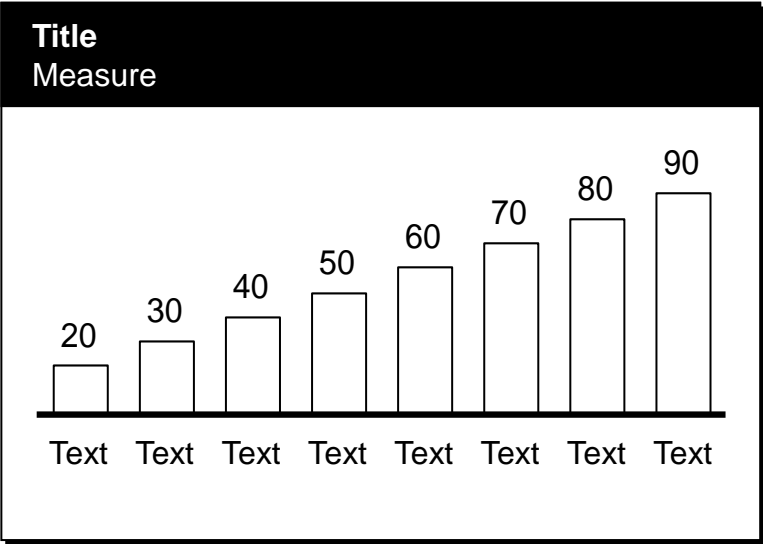
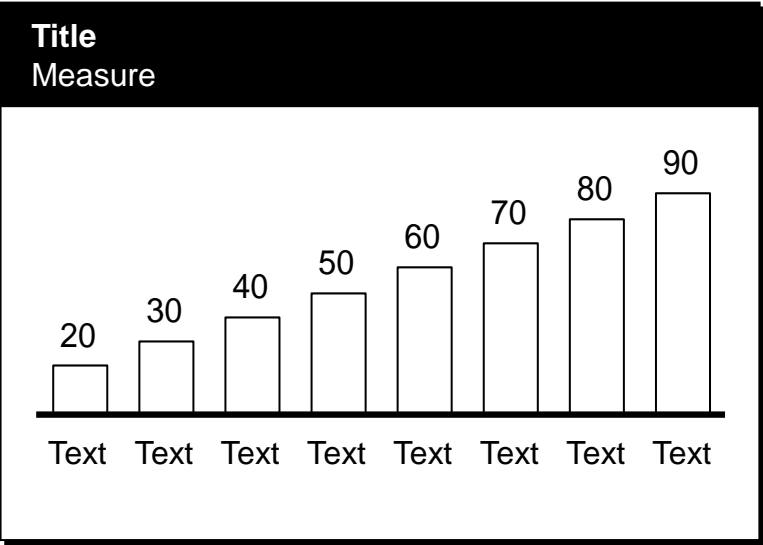
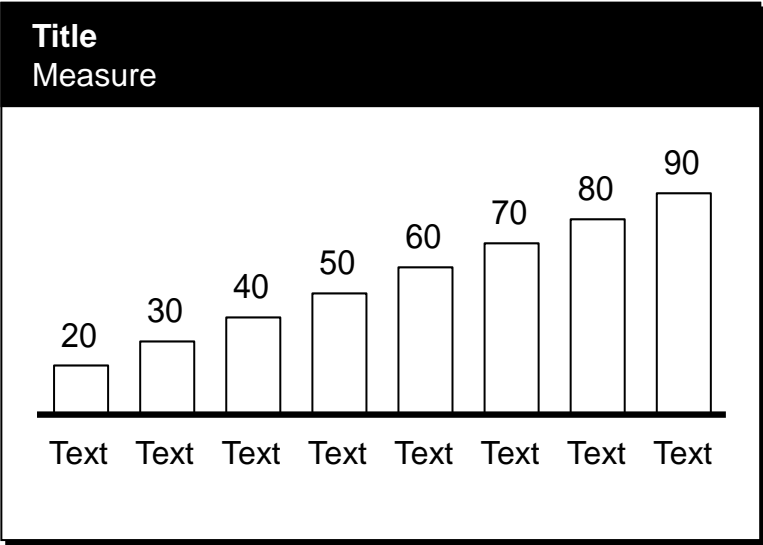

* Footnote

Unit of measure

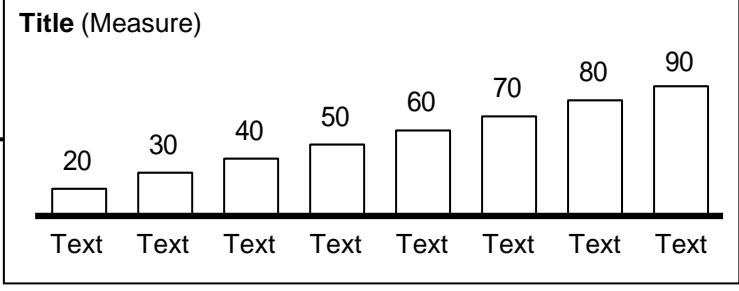
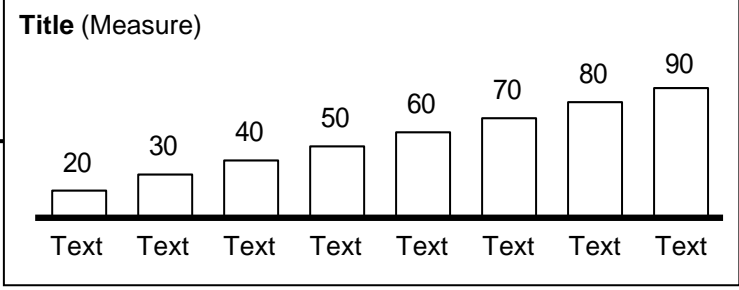
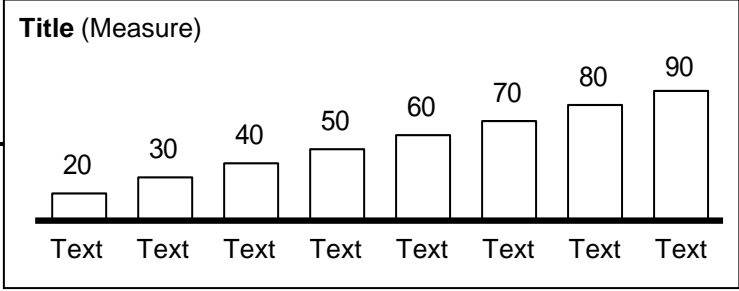
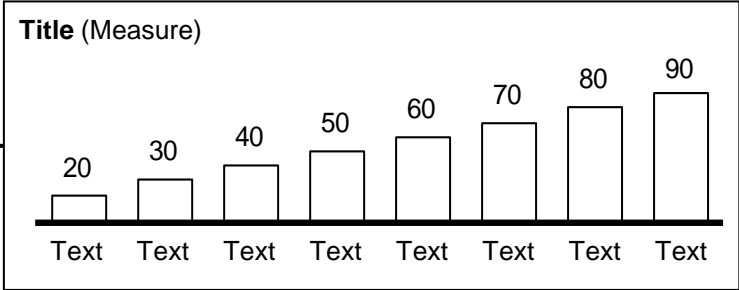
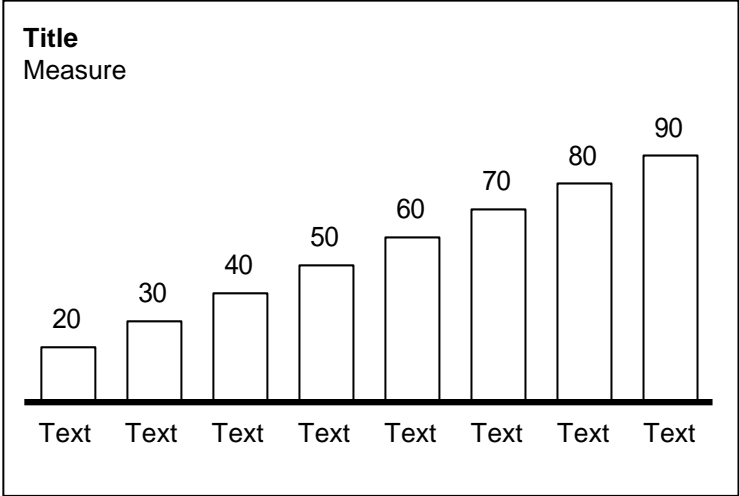

* Footnote
Source: Source

Unit of measure

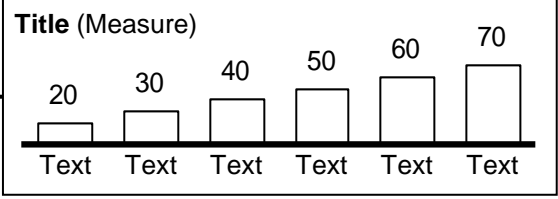
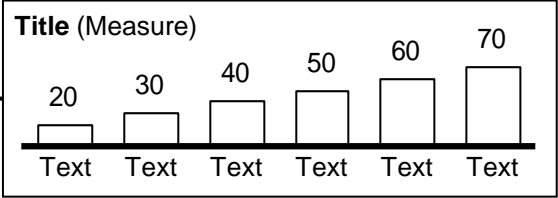
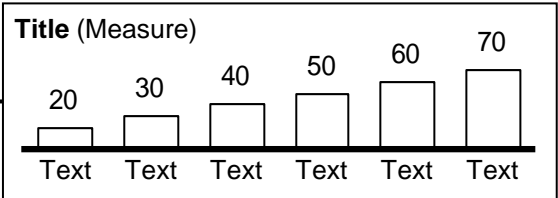
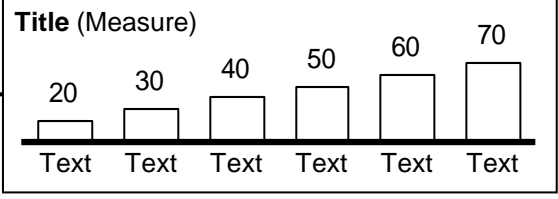
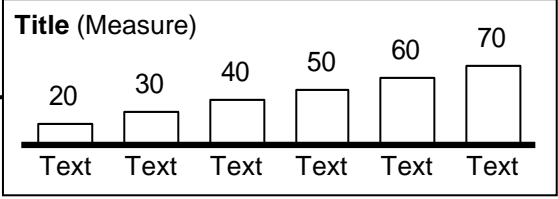
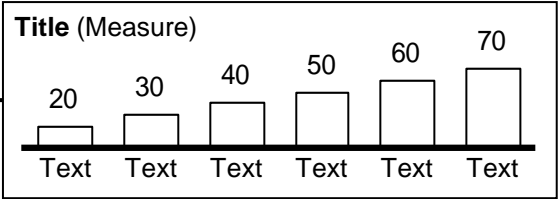
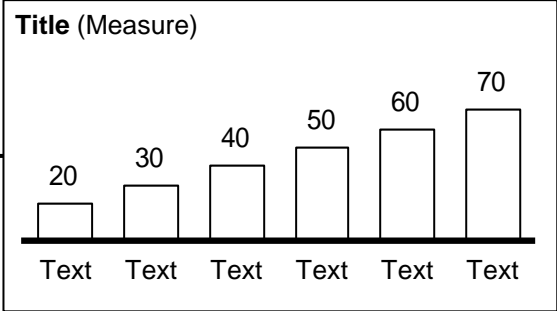
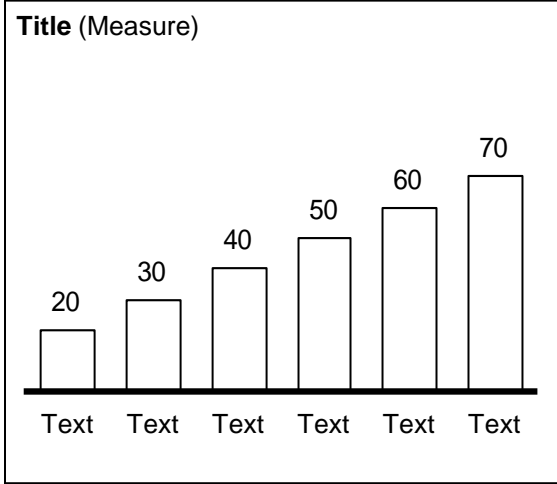

* Footnote
Source: Source

ROIC TREE ANALYSIS

Percent

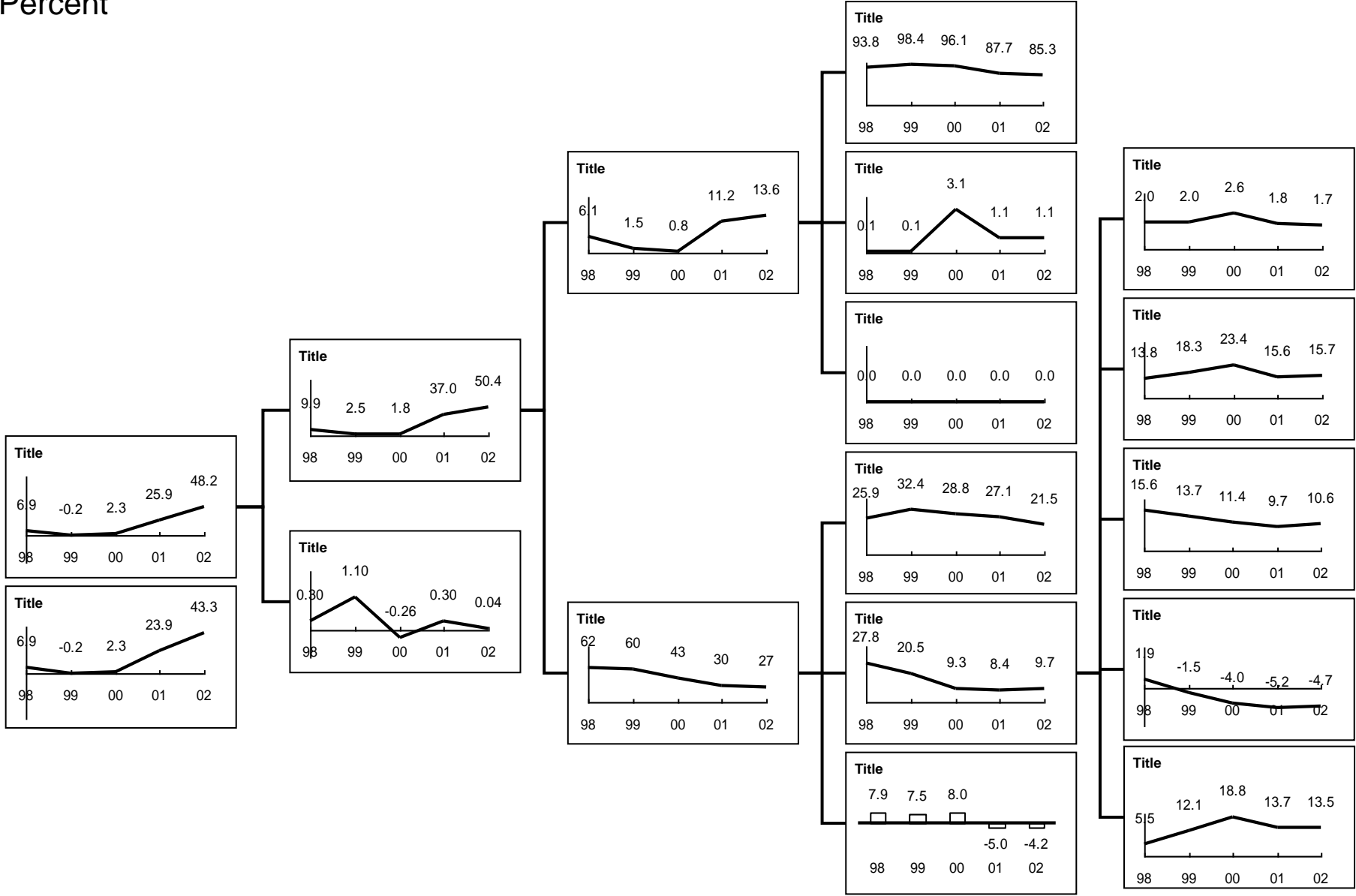
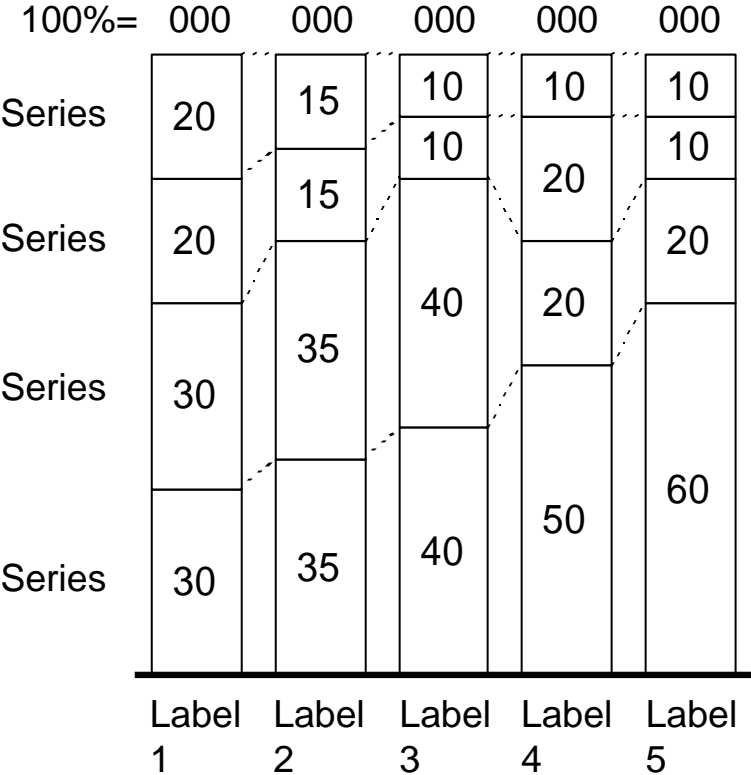

EXHIBIT TITLE

Unit of measure

Text



Text

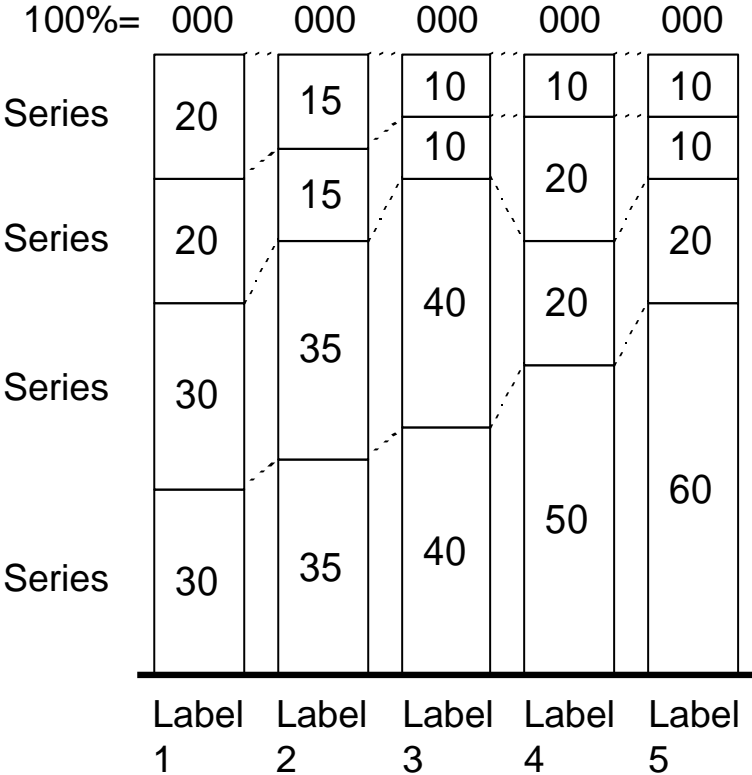

* Footnote

EXHIBIT TITLE

Unit of measure

Text

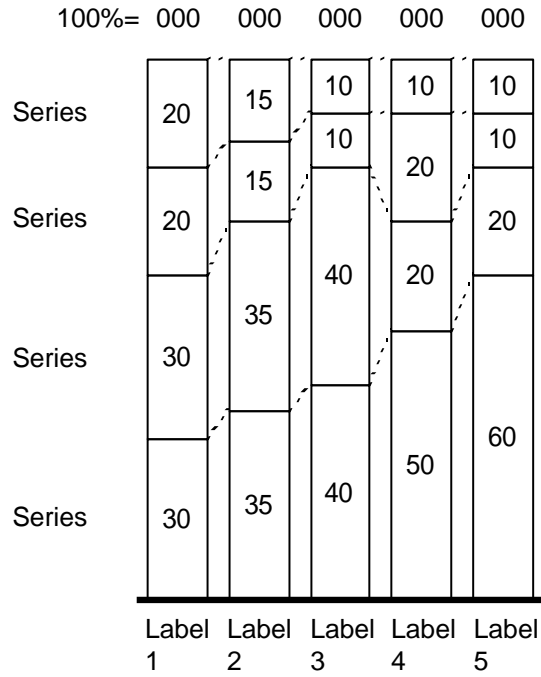

Text

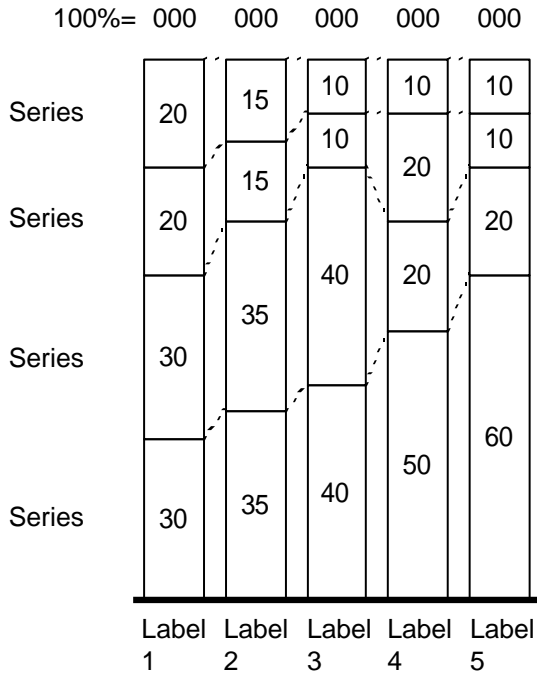

Text

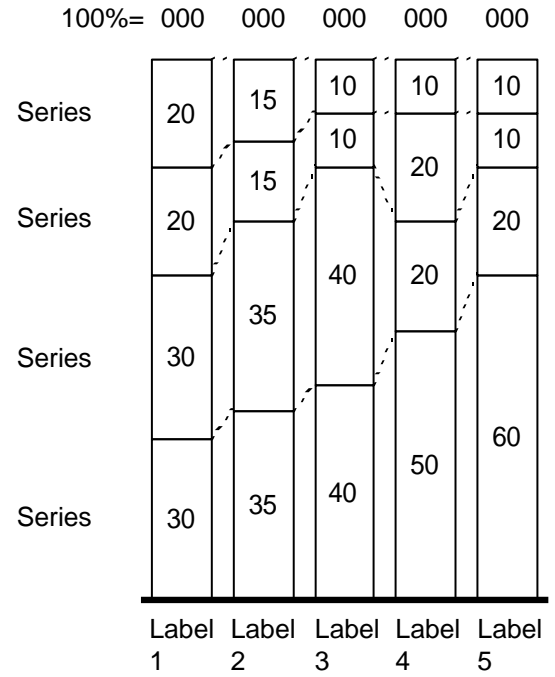

* Footnote

EXHIBIT TITLE

Unit of measure

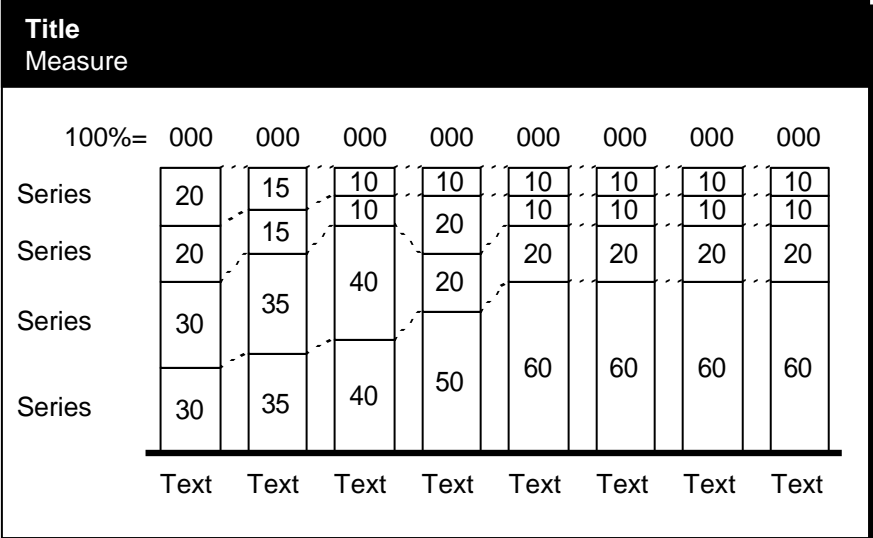
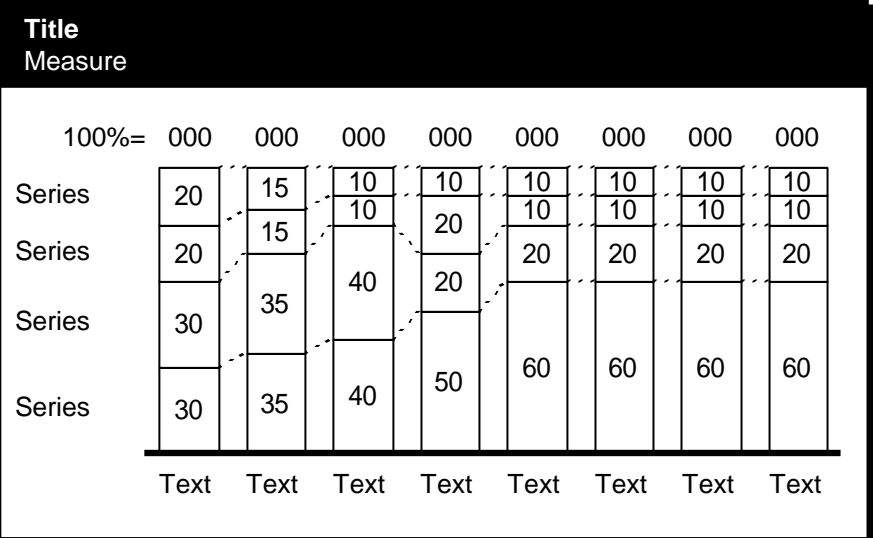
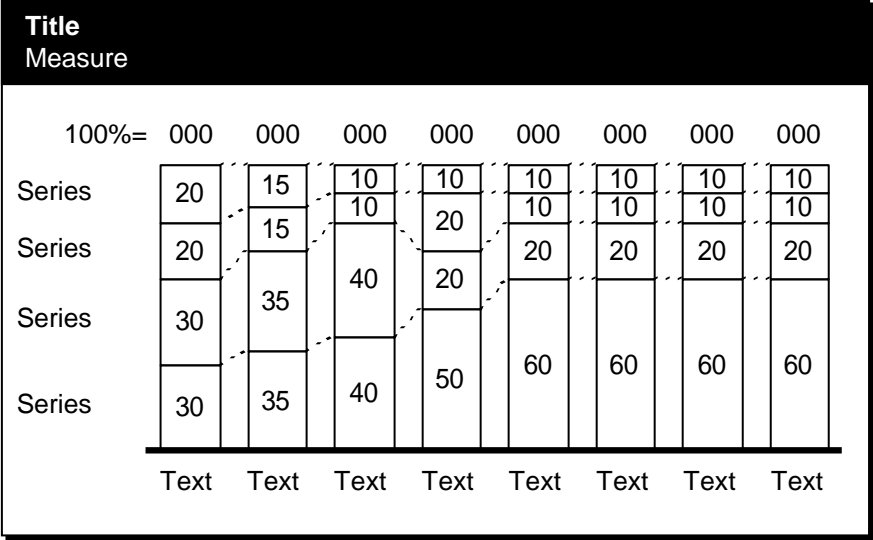
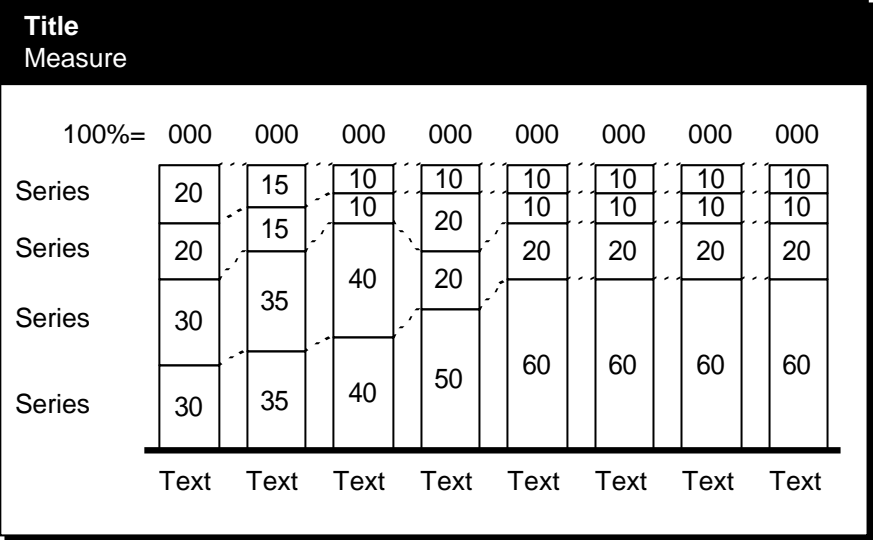

* Footnote
Source: Source

Unit of measure

Title
Measure

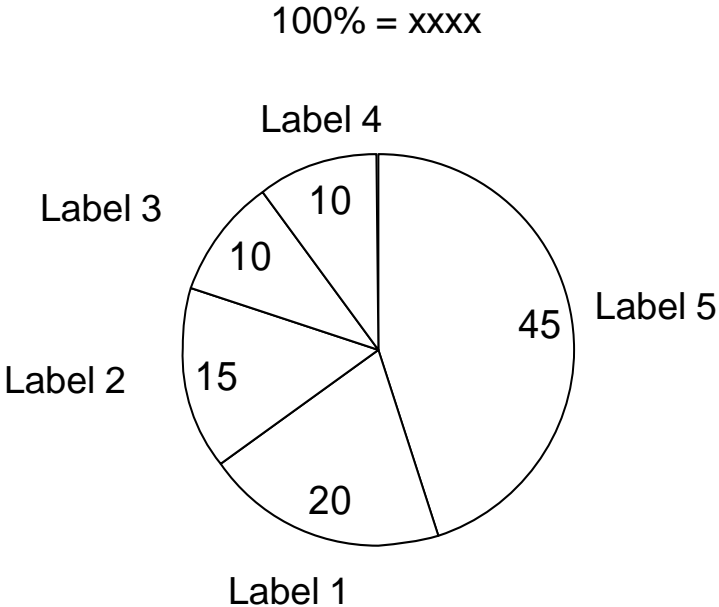

Title
Measure

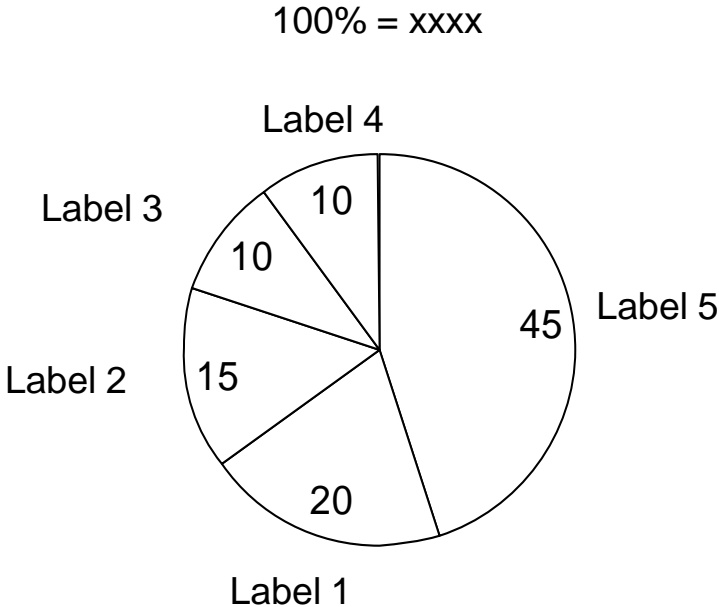

* Footnote

Unit of measure

Title
Measure

100% = xxxx

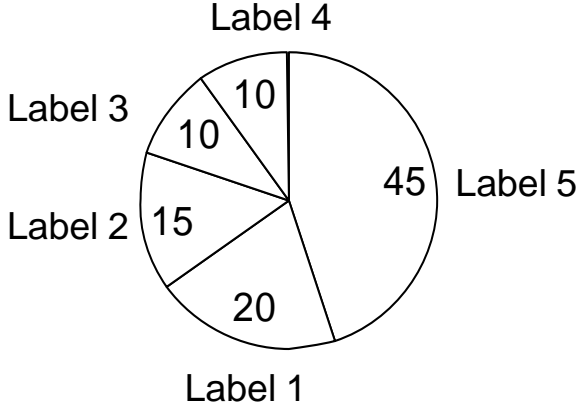

Title
Measure

100% = xxxx

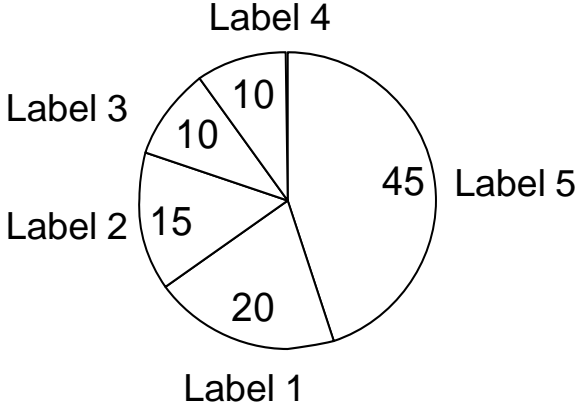

Title
Measure

100% = xxxx

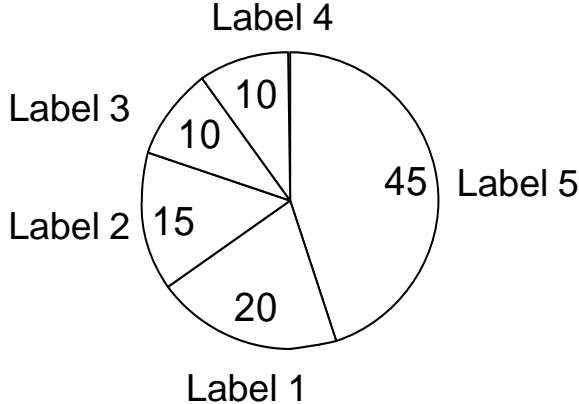

* Footnote

Unit of measure

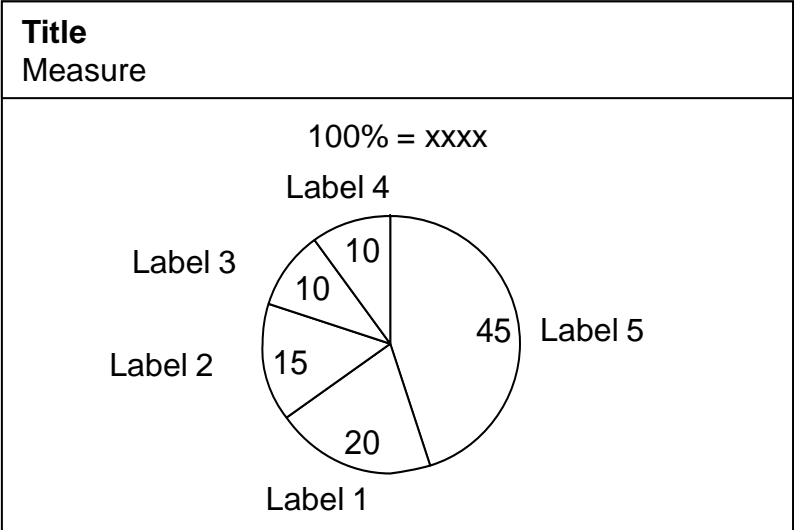
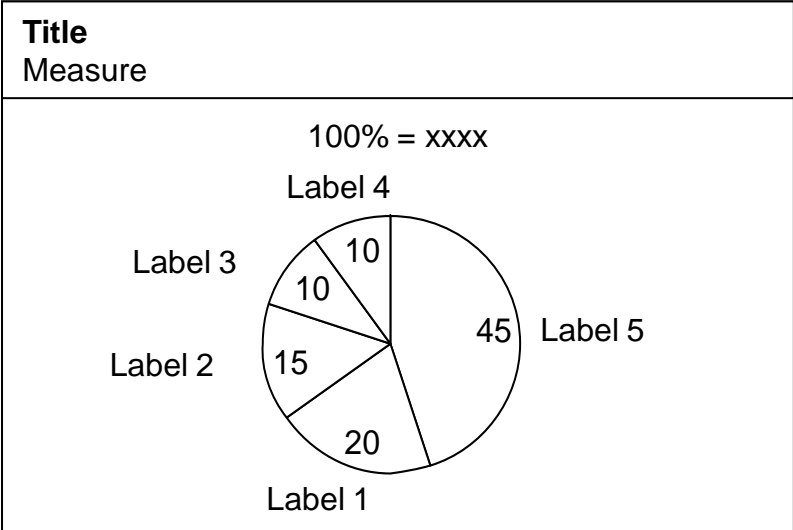
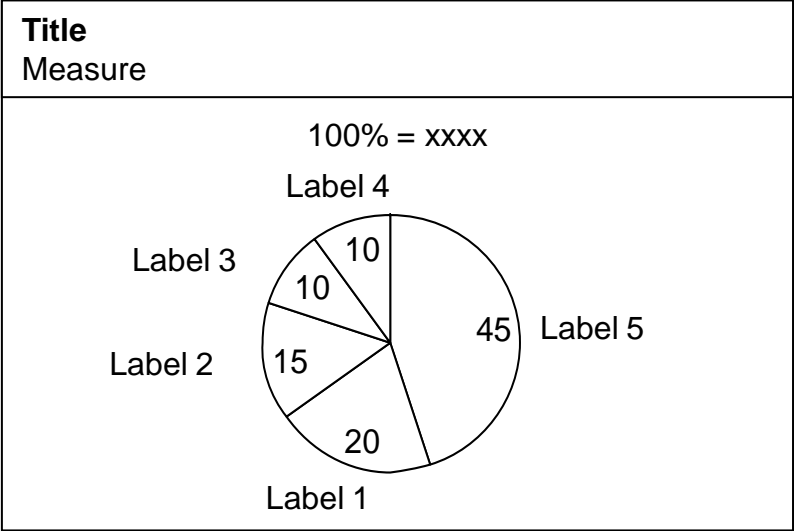
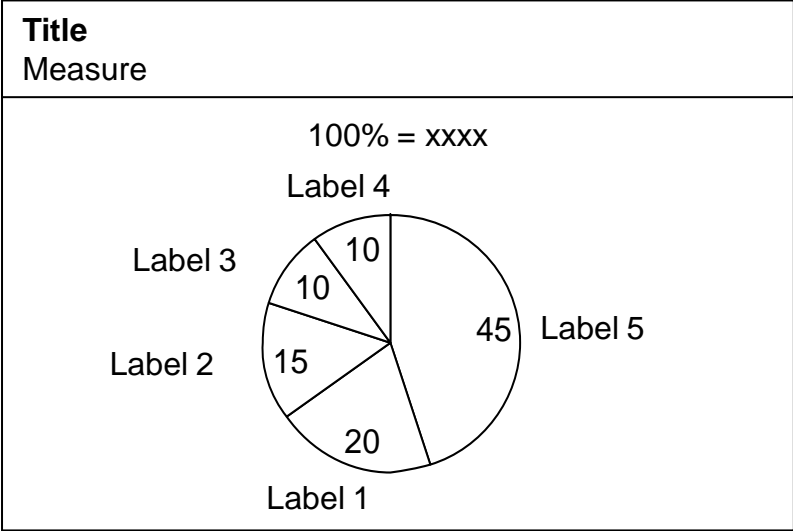

* Footnote
Source: Source

Unit of measure

Title
Measure

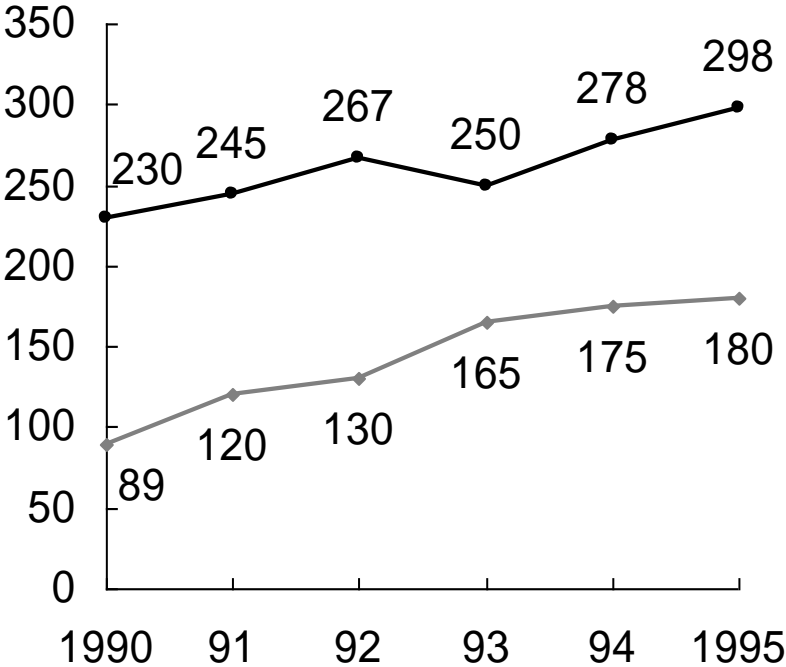

Title
Measure

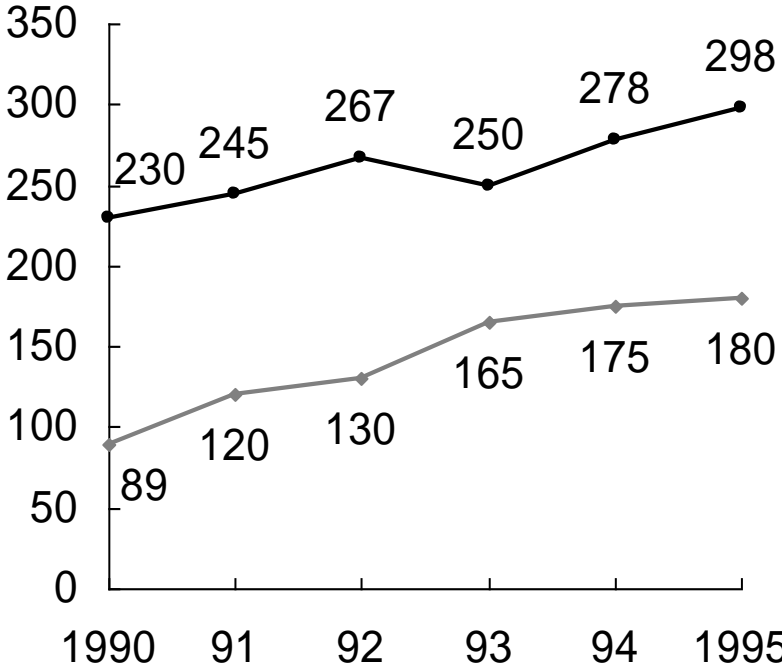

* Footnote

Unit of measure

Title
Measure

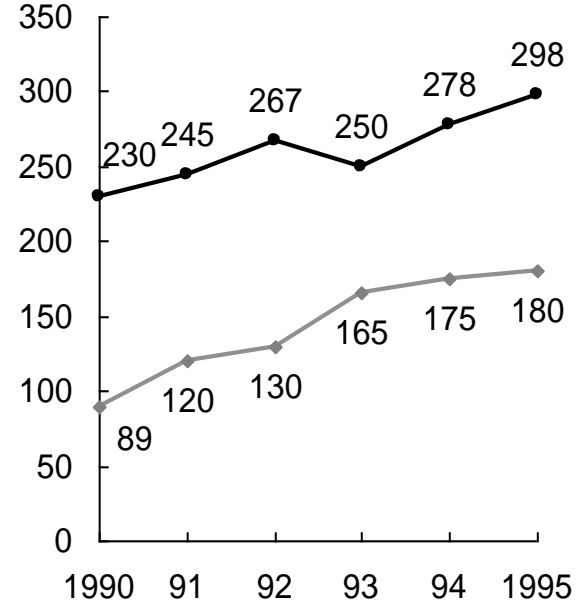

Title
Measure

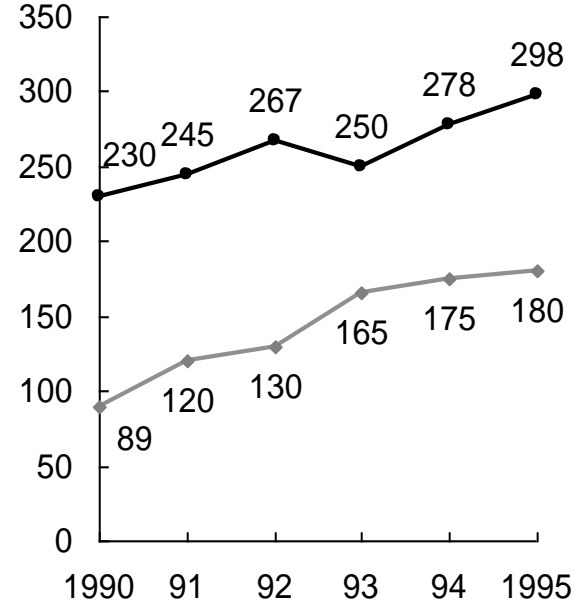

Title
Measure

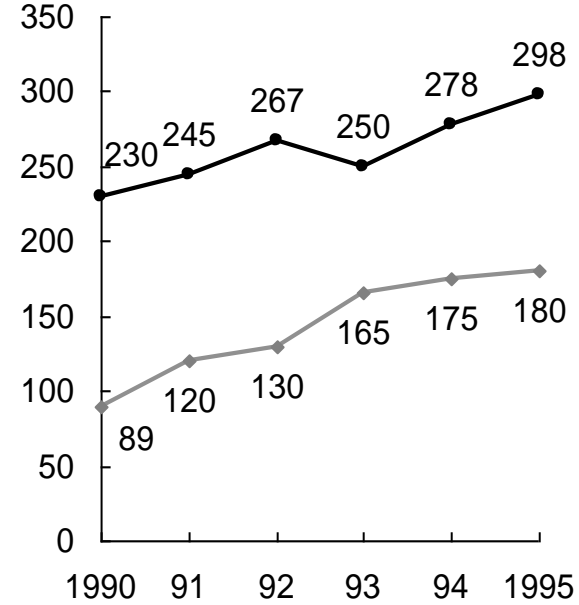

* Footnote
Source: Source

Unit of measure

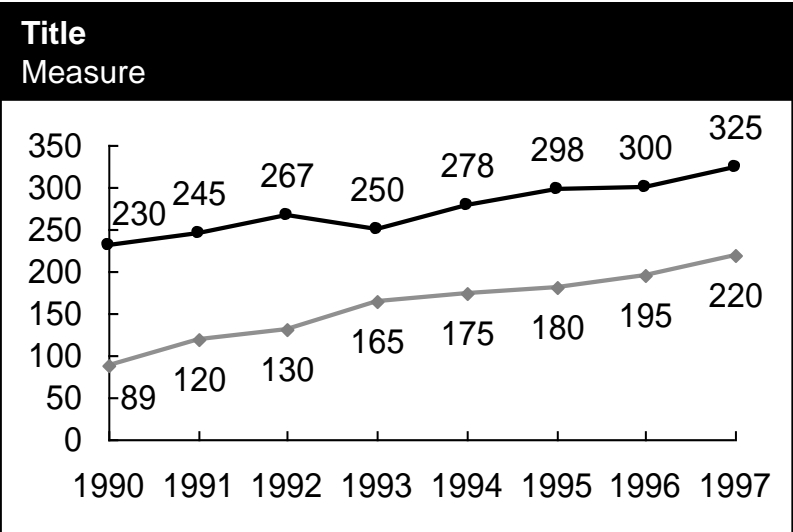
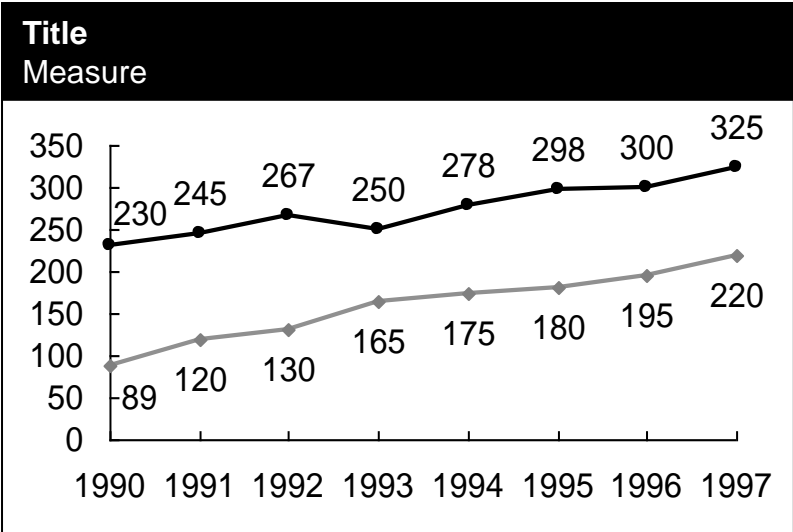
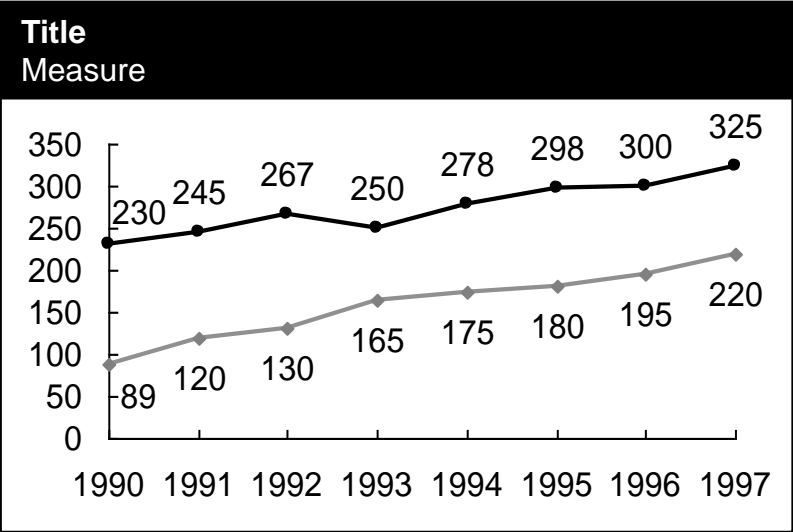
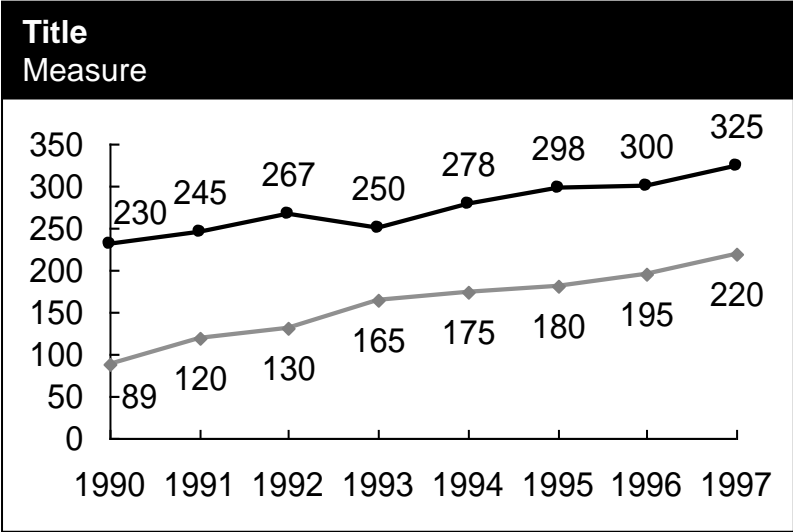

* Footnote

Unit of measure

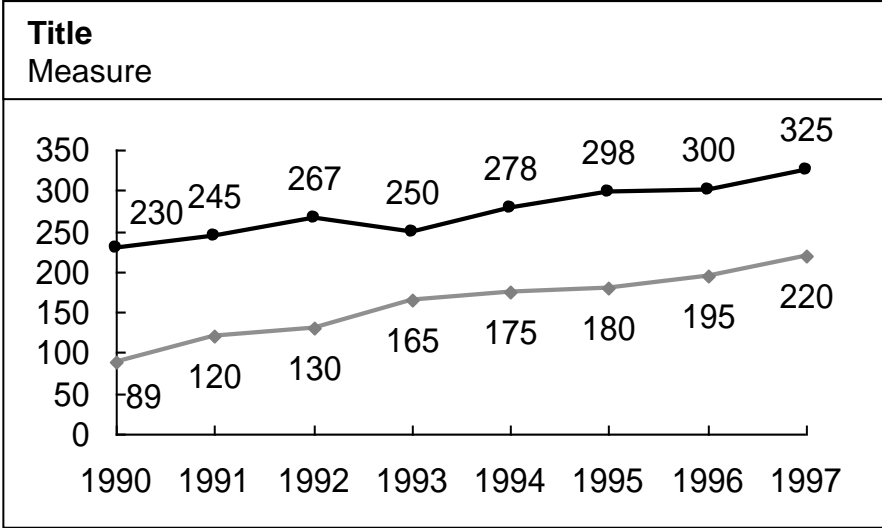
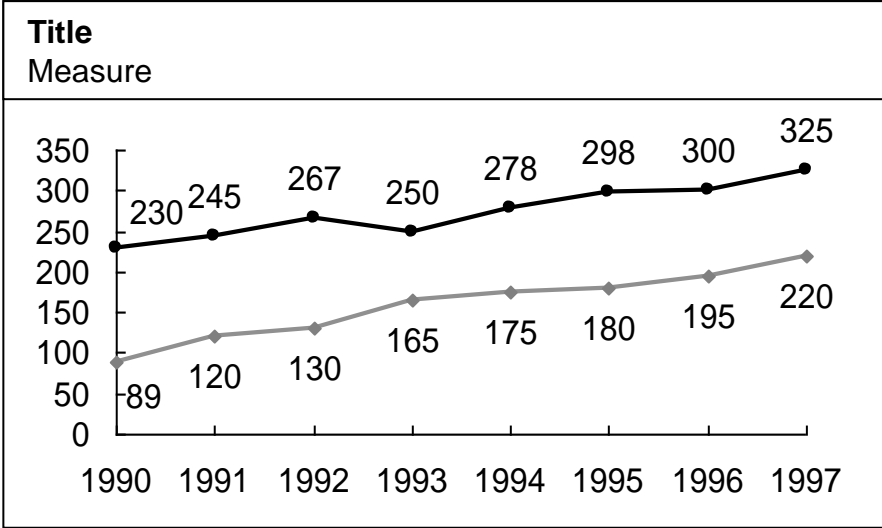

Text

* Footnote

Unit of measure

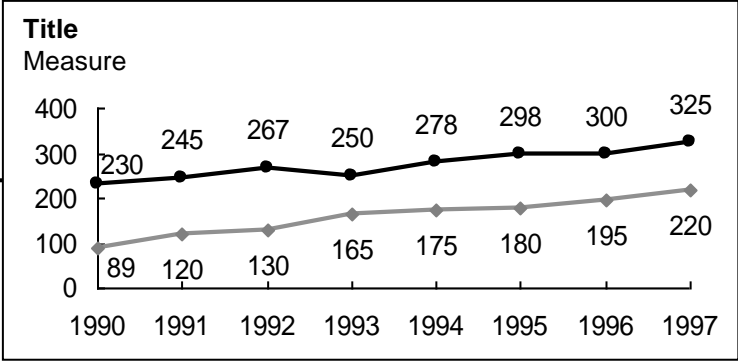
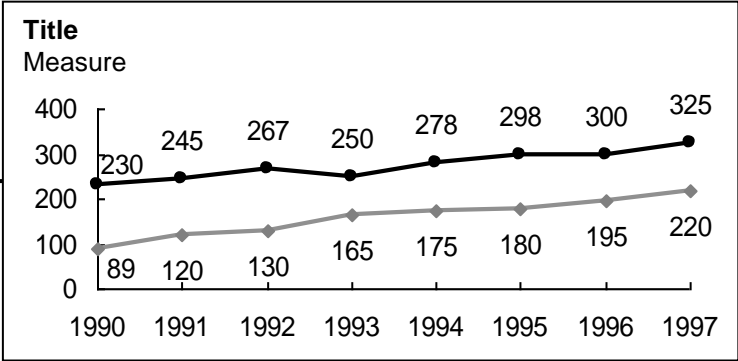
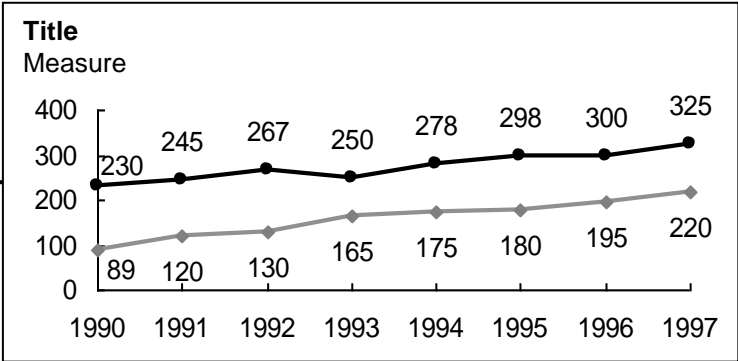
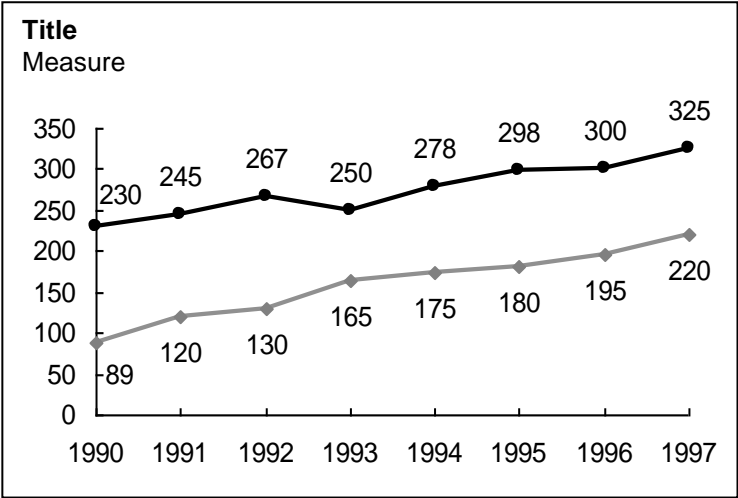

* Footnote

Unit of measure

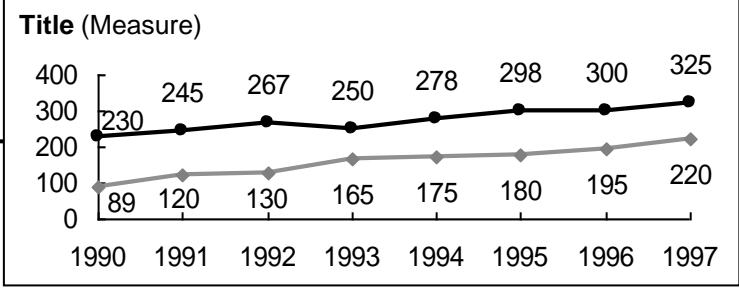
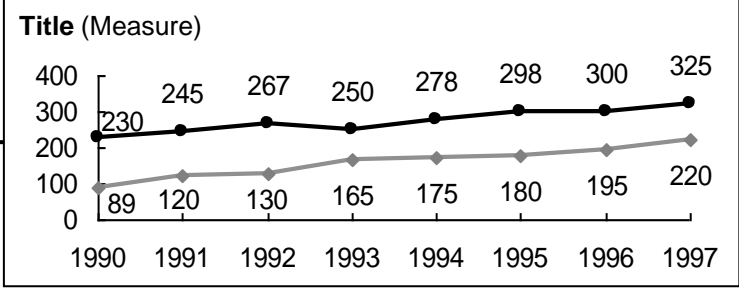
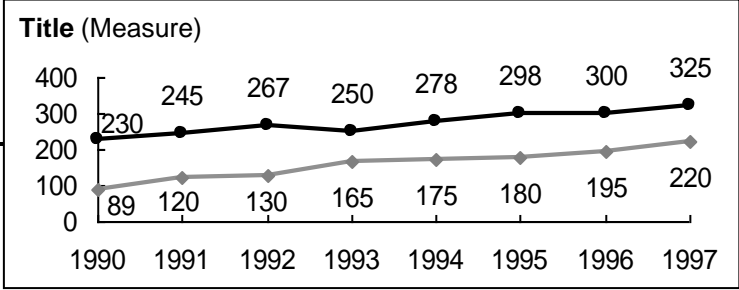
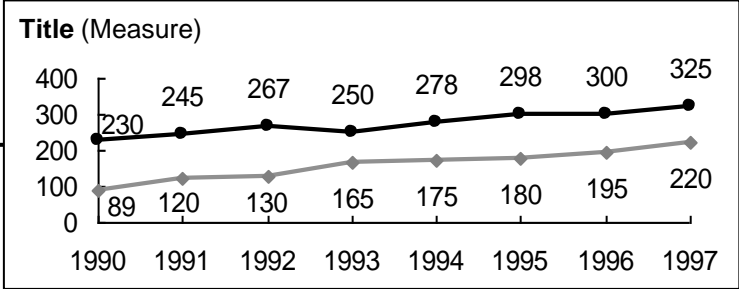
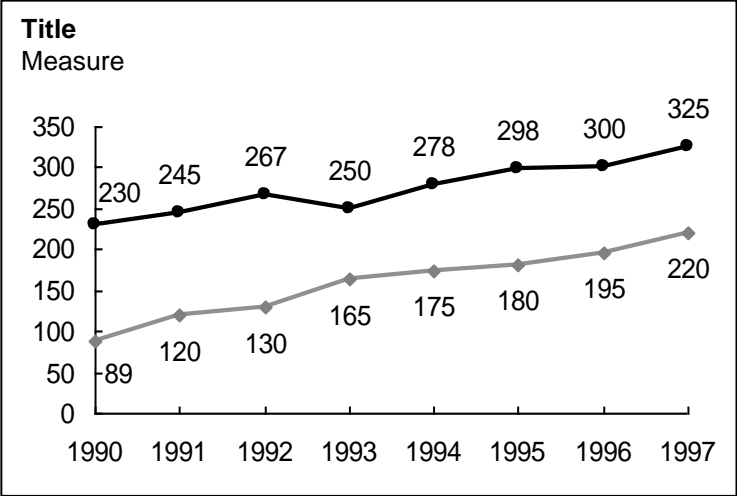

* Footnote

STICKER AND OTHERS

EXAMPLE BACK UP REVISED

ESTIMATE TENTATIVE

PROPOSED HYPOTHESIS

CONCEPTUAL ILLUSTRATIVE

PRELIMINARY CONFIDENTIAL

ROUGH ESTIMATE VERY PRELIMINARY

TO BE COMPLETED

ONLY FOR DISCUSSION

WORK IN PROGRESS

STICKER AUTOMAKER

EXAMPLE BACK UP REVISED

ESTIMATE TENTATIVE HYPOTHESIS

PROPOSED CONCEPTUAL ILLUSTRATIVE

CONFIDENTIAL PRELIMINARY

ROUGH ESTIMATE VERY PRELIMINARY

TO BE COMPLETED WORK IN PROGRESS

ONLY FOR DISCUSSION

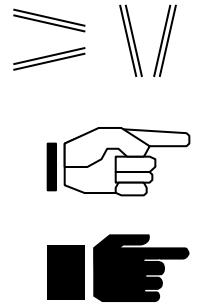
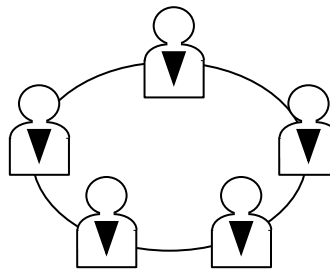
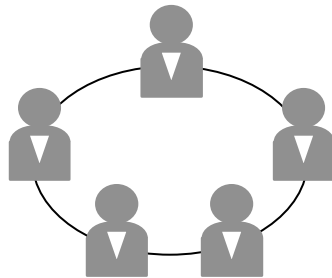
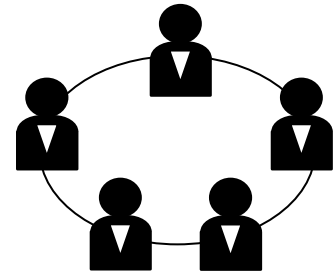
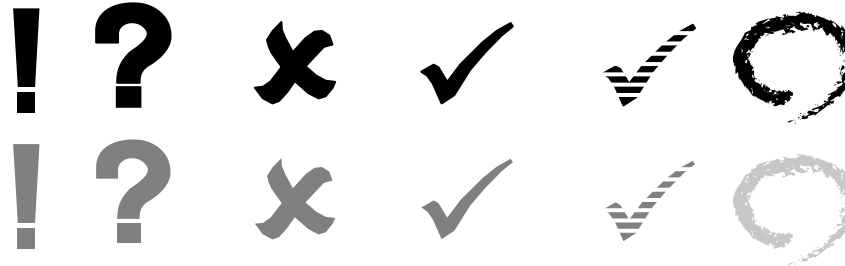
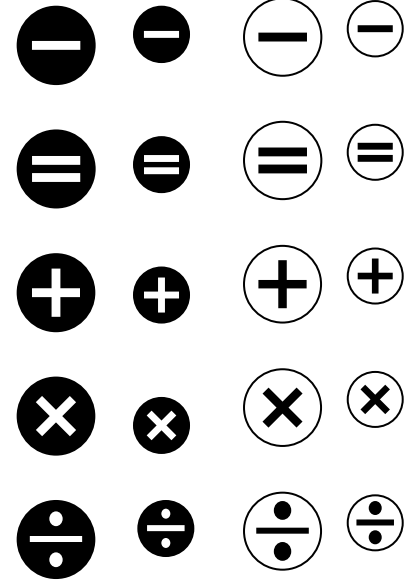

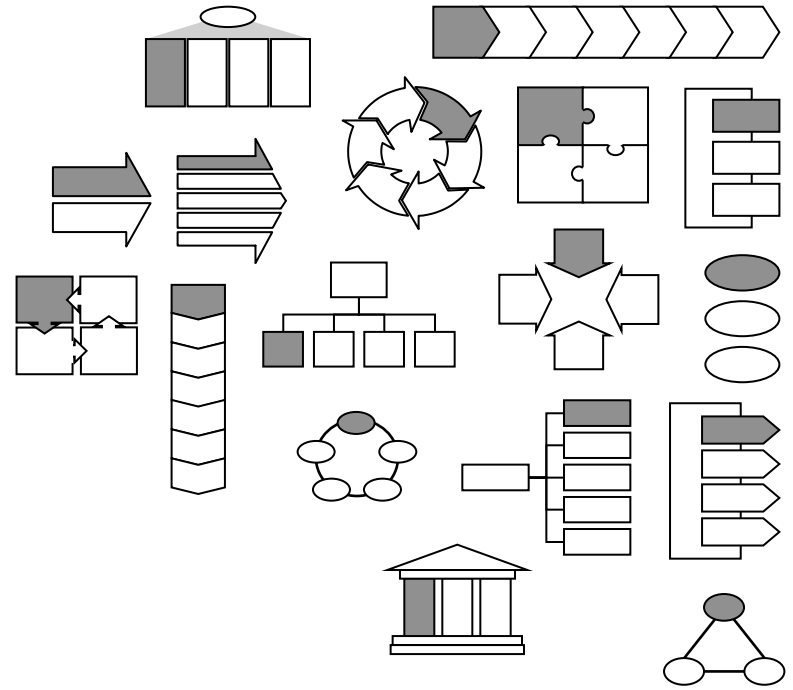
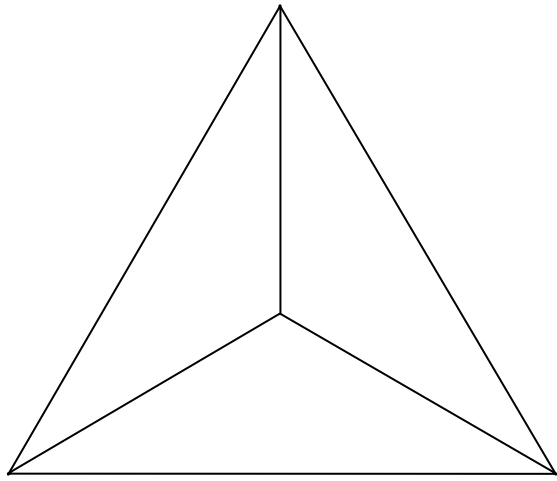

- High
- ◐ Medium
- Low

STICKER AND OTHERS

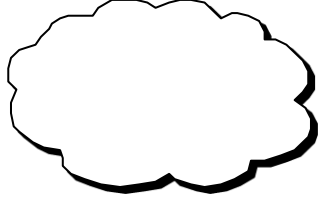
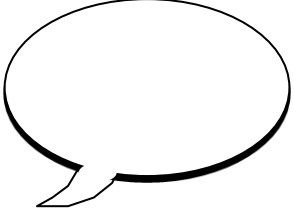
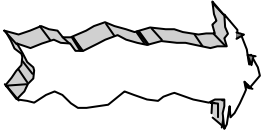
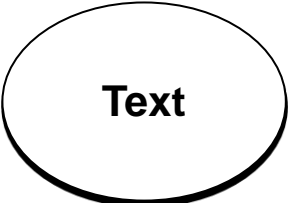
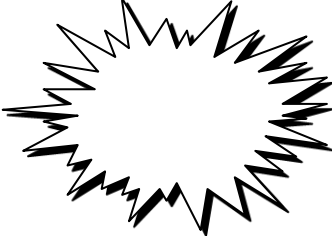
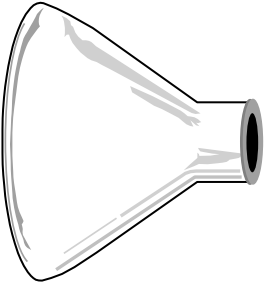
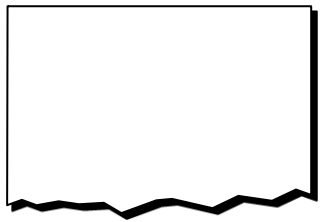
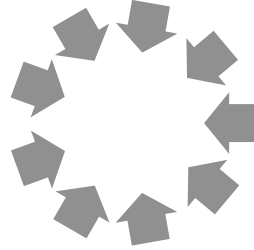
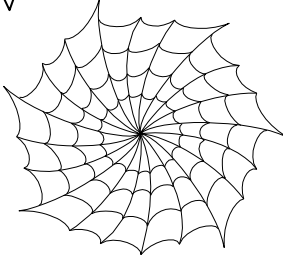
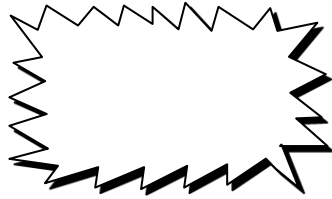
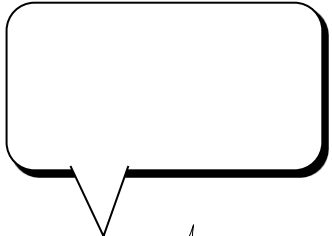
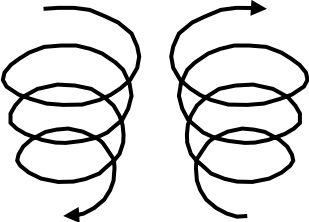
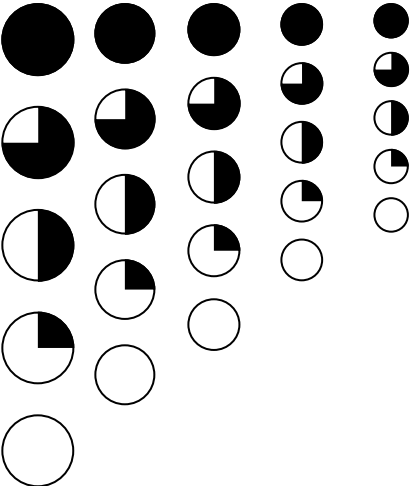

MAPS

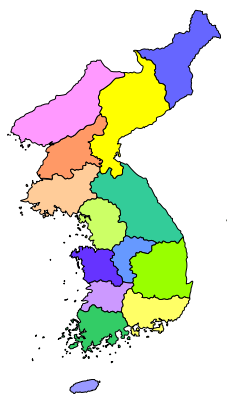
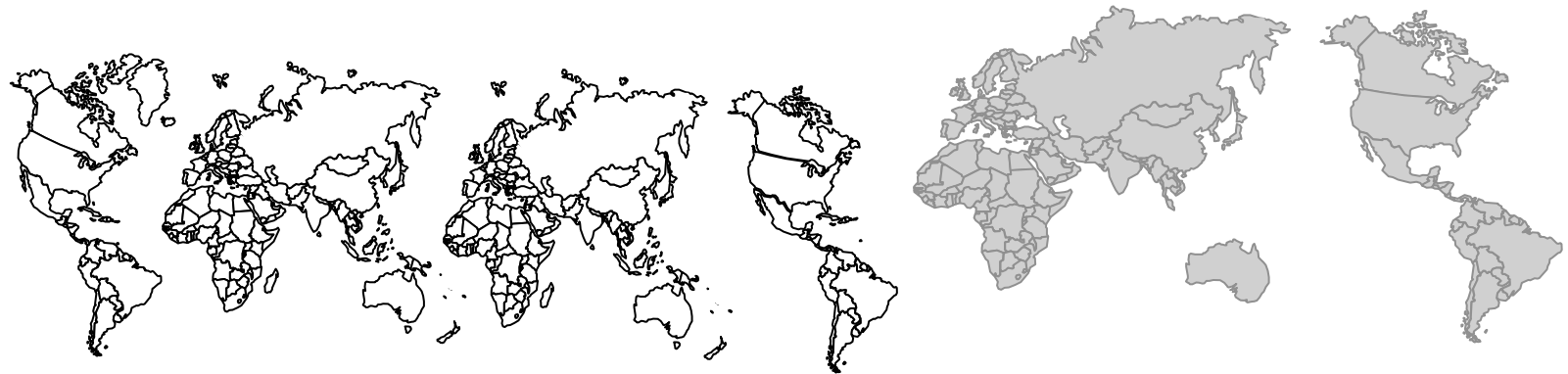

APPENDIX

END OF DOC